

THE
G R E A T A R T
O F
A R T I L L E R Y
O F

CASIMIR SIMIENOWICZ,

Formerly LIEUTENANT-GENERAL of the
Ordnance to the King of *Poland*.

Translated from the FRENCH,
By *GEORGE SHELVOCKE*, Jun. Gent.

Illustrated with Twenty Three Copper Plates.



L O N D O N:
Printed for J. T O N S O N at *Shakespear's Head* in the *Strand*.

M D C C X X I X .



The TRANSLATOR'S P R E F A C E.



IT is said that Prefaces to Books, as well as their Title-Pages, are too often guilty of promising much more than ever the *Readers* can discover in them: But this shall not be the Case here; for what I intend to advance in Favour of this *Work*, shall be as simple as its Title. I shall only say, That it were to be wished, that the greatest part of Those, who have undertaken to instruct the Public in the various Branches of the *Practical Arts*, had been indued with Knowledge or Industry enough, to qualify them for the Management of their particular Provinces with such Address, and to such useful Purpose, as our Author. This is all I need say, concerning Him or his Work; for it would be both vain and impertinent in me, to take up your Time with an *Encomium* upon either; since the Authority of *Casimir Simienowicz* has been formerly, and is still, as it were Sacred amongst *Pyrobolists* and *Fire-Workers*; as is particularly evident from His hav-

The TRANSLATOR'S PREFACE.

ing been long ago translated into the most noted of the *European* Languages; and from the joint Concurrence of the present Judicious in these Matters, by the common Suffrage of whom he is allowed to be the Father of Sound and Intelligent *Pyrobalists*.

My Design therefore in this *Preface* is only to give you a very brief Account of this *Translation*; to which I shall annex a few Lines relating to the History of *Saltpeter*, which I shall borrow from very good Authority; and which I promise myself will be both New and Acceptable to most of Those, who apply Themselves to the Study and Practice of the *Military Pyrotechnics*.

This *Translation* then was undertaken and completed purely by the Encouragement of Colonel ARMSTRONG, the present *Surveyor-General* of his MAJESTY's *Ordnance*, Who considering with Himself, That tho' our Language abounds in Learned Tracts on almost all the Subjects that are truly Useful, It is strangely defective in such as might tend to the Preservation of our Liberties, and the Honour of our *Arms*, amongst our Neighbours; the most Warlike Nations in the World! He concluded that by naturalizing the most celebrated *Author* in this Kind, a great Step would be taken towards recovering our *Pyrobalists* and *Fire-Workers*, from the Lethargy they seem to have been wrapped in for many Years past; and towards exciting Them to an Emulation of their Glorious Ancestors, who always endeavoured to be Foremost in all *Mar-tial Knowledge*. And since the *Genius* of our Nation is still equally inclined to *War* and to *Peace*, it is to be hoped, That our *Military Artists* will as readily improve upon this *Stranger*, as our *Civil Artists* have upon innumerable *Foreigners* in their Way.

But it may be asked by Those, who have heard that this *Work* was originally written in *Latin*, why it was not rather translated from that Language, than from the *French*? To give a short Answer to this Query, I must tell

tell you, that it could not be procured in *Latin*: And it will not appear strange that there should be such a Scarcity of it, in its Original Tongue; if it be considered, That our *Author* was of *Poland*, where the *Latin* is in universal Use, and where the Professors of this *Art* are very numerous, especially in its *Recreative Branches*, which are practised by the *Poles* as a common Mystery, or Trade; so that notwithstanding there may be several Thousands of this *Work* extant in the *Latin* Tongue, they are particularly closeted up by that Nation as an invaluable Treasure.

If I could have procured one of the Original *Copies*, it would doubtless have saved me a great deal of Trouble; for the *French* Translation is now grown very obscure and obsolete; and what contributes to make it almost Unintelligible in many Places, it is the most Carelessly-printed Book I ever saw, scarce a Page of it being free from gross Typographical Errors.

Under these Disadvantages I laboured throughout this whole Translation; so that if any *Inaccuracies* have escaped me, the *Candid Reader* would forgive them, as soon as discovered, if He would but consider how easily I may have been misled into them, notwithstanding all the Care I may have taken to guard myself against them; and if at the same Time He did but know what Pains I have really been at, to purge my *Original* of a vast Number of Erroneous Blemishes of all Sorts, that the Whole might answer the Design of this Undertaking. But I hope that all the Material Mistakes I have fallen into, will be corrected in my Table of *Errata*. And here it may not be Unseasonable to inform you, That the Confection and Proportions of the several *Compositions* have been compared by a Friend with the *German* Translation; for without some such Help, it would have been next to Impossible to have rectified what was amiss in that Important Article.

In a word, you have here the compleat Body of my *Original*, in the clearest and most familiar Style I am Master

ster of, as much as possible divested of the tedious Circumlocution and Prolivity of the *French*, and expressed in such *Terms* of Art and Science as seem to be most in Use with the present *Learned*.

I shall now enter upon what I promised you with reference to *Saltpeter*; to the End, that you may be as well versed in whatever relates to that wonderful *Salt* and *Soul* of *Artillery*, as it becomes a professed *Pyrobolist* to be: And I am the more encouraged to it; because the *Latin* Quotations, which are interspersed in the Treatise I shall here abridge, must render the Reading of it imperfect and unpleasant to Those who are not tolerable Masters of that Language. What follows then, is the Substance of a Paper in Bishop *Sprat's History of the ROYAL SOCIETY*, intitled *The History of Saltpeter by Mr. Henshaw*.

He says, " That whether the *Nitre* of the Ancients be
 " of the same Species with the *Salt*, which is commonly
 " known by the Name of *Saltpeter*, is variously disputed
 " by very learned Authors: But by his Observations, and
 " by the Practice of *Saltpeter*-Men, and Refiners of *Salt-*
 " *peter*, He suspects that the Confidence of those who
 " hold them to be different *Salts*, proceeds chiefly from
 " their being unacquainted with the *Phænomena* or Ap-
 " pearances of *Saltpeter* in the Making and Refining of
 " it: And also to their comparing Double Refined *Salt-*
 " *peter* (of which *Gun-powder* is made) with that De-
 " scription of *Nitre* and *Afronitre*, in *Chap. X. of Book*
 " *XXXI. of Pliny's Natural History*, where he tells us,
 " That *Afronitre* was almost of a *Purple Colour*; and that
 " the *Egyptian Nitre* was brown, and gritty or stony; ad-
 " ding afterwards that there were *Nitrariæ* from whence
 " the *Nitre* came out of a yellow Colour. This, *Mr. Hen-*
 " *shaw* says, is sufficient to have hinted to any one but
 " moderately versed in the Modern Way of ordering *Salt-*
 " *peter*, that the Ancients were not at all skilled in Re-
 " fining their *Nitre* from the *Earth* and common *Salt*,
 " that

“ that is usually mingled with it; nor from that foul yellow Oil, which it seems did accompany their *Nitre* as it doth our *Saltpeter* in great abundance; for *Pliny* takes Notice of it when he mentions the removing of *Nitre* (after it is grained) out of the *Nitraria*, saying, *Here also an Oil intervenes which is good against the Scab or Mange in Animals.* This greasy Oil (which the Workmen were used to call the *Mother of Saltpeter*) Mr. *Henshaw* takes to be the crude and unripe Part of it; and says, that it doth by Nature so wonderfully adhere to every Part else of *Peter* (it may be, ordained for the Nutriment and Augmentation of it) that the Separation of it is the sole Cause of the great Charge and Labour that is required in refining of *Peter*: For if this Separation is not effected, the *Peter* will be yellow or brown, or of some other dark Colour.”

He then quotes a Passage from *Scaliger*, which is also quoted by our Author (namely) *For we have frequently observed a kind of Lustre of a glimmering Purple in Salispretræ Terris; or in Saltpetrous Earths; whereas Casimir has it Salispetræ Cirris, or in the Shivers of Saltpeter; but it is likely that they may both be in the right.* He then says, “ That if a Saltpetrous *Lixivium* be boiled up to a Consistence without filtering it thro’ Ashes, or giving the *Salt* leave to Chrystalize, you may perhaps find something not unlike the *Nitre* of the Ancients.”

He then quotes this Passage from *Pliny*, “ *There is a little Nitre found in some scorched Vales of Media, where it is called Halmiragha: And a less quantity of a coarser Sort of it is also found in Thrace in the Land about Philippi, where it is called Agrium.* And then says, that a Refiner of *Saltpeter* gave him an Account parallel to what *Pliny* asserts; by telling him, that near *Sophia* and *Santa-Cruz*, and in several other Places in *Barbary*, he saw *Saltpeter* shoot out of the Surface of the Ground, as thick and white as Hoar-Frost, on many barren and desart

“ Lands; but that this does not happen till the begin-
 “ ning of the Rains in *August* or *September*, and that it
 “ is the falling of the Rains which causes the *Saltpeter*
 “ to shoot out in little Chrystals; and that the People
 “ of the Country take it up as clean as they can, and
 “ sell it to Merchants: And that, by the Relation of an
 “ *India* Merchant, it is much after the same manner that
 “ the Inhabitants of *Pegu* in *East-India* collect it and sell
 “ it, saving that they refine it once before they deliver
 “ it to the Merchants.

The next Remark he takes out of *Pliny*, is this:
 “ *There are Nitrous Waters in many Places, but which*
 “ *cannot be condensed or grained by the Heat of the Sun.*
 “ *The best is found in Macedonia, which they call Chalastric-*
 “ *cum, and is very pure and white, and nearly like Salt.*
 “ *There, is a Nitrous Lake, that has a Spring or Fountain*
 “ *of fresh Water rising up in the Middle of it: In this Lake*
 “ *they find Nitre about the Time of the Dog-Days; when*
 “ *it begins to swim on the Surface, and so continues for nine*
 “ *Days; after which it ceases for nine Days; which being*
 “ *expired, it floats again as before, and then ceases as be-*
 “ *fore. If during those Days that the Nitre is generated*
 “ *there happen to fall any Showers of Rain, they cause the*
 “ *Nitre to be saltier than ordinary; but if any violent Winds*
 “ *arise they spoil it, because they make the Water foul and*
 “ *muddy. There is a much greater Quantity of it made in*
 “ *Egypt, but it is not so good; for it is of a dark Colour,*
 “ *and gritty or stony, and made almost after the same Man-*
 “ *ner as common Salt; with only this Difference, that into*
 “ *Salt-Pits they pour Sea-Water, and into Nitrariæ, Water*
 “ *of the River Nile.*

Upon this, Mr. *Henshaw* says, “ It will be no diffi-
 “ culty to conjecture, how such great Plenty of *Nitre*
 “ should be found in the Places above-mentioned, if we
 “ consider that Lakes are the Receptacles of Land-Floods,
 “ and that great Rains might easily bring it to the Lake
 “ in

“ in *Macedonia* from the higher Parts in the Country
 “ about it. And for the River *Nile* (he says) there
 “ must needs be less Scruple concerning it, if we call to
 “ mind that once in a Year it sweeps with an impetuous
 “ Overflow the burnt and barren Desarts of *Africa* under
 “ the Torrid Zone; where, by the Relation of Travel-
 “ lers, those Sands are visibly full of *Nitre*; and those
 “ few Springs and Wells that are found there, are for that
 “ Reason so bitter, that the *Moors* and their Camels are
 “ forced to make a hard Shift with them in their long
 “ Journeys.

“ He says, he drew good *Rock Peter* out of those *Sti-*
 “ *riæ* which are usually found hanging in arched Cellars
 “ and Vaults.” And here it may not be improper to re-
 mark that the Word *Stiria* signifies an Icicle, or any thing
 like it; whereas *Scaliger* expresses himself with reference
 to this Matter by the Word *Stria*, which in this Case pro-
 perly signifies a Furrow as I have rendered it in the first
Chapter of the *Second Book*: But I suppose it is found both
 in *Stiria* and in *Strie*. However this be, I shall not
 waste your Time with saying any Thing farther concern-
 ing it.

But to steer more directly upon our present Subject,
Saltpeter; Mr. *Henshaw* says, “ It is likely that the Air
 “ is every where full of a Volatile Kind of *Nitre*, and that
 “ Lime and Plaster do strongly attract it, but Dew and
 “ Rain convey much of it to the Earth; and that the
 “ Clouds seem to be spread out before the Face of the
 “ Sun, either to imbibe some Part of his Influence, or
 “ to have a Salt generated in them to advance the Ferti-
 “ lity of the Earth; and he thinks they return not with-
 “ out a Blessing, in that he has more than once extracted
 “ *Saltpeter* out of Rain and Dew; but in the greater
 “ Plenty from the latter; and that even when it is ex-
 “ tracted from Dew, it is accompanied with a greasy pur-
 “ ple Oil in great abundance; and adds, that upon Tryal
 “ he

“ he found, that most standing Waters, and even deep
 “ Wells, have some small quantity of *Saltpeter* in them;
 “ and assures us, that he also found some in the Fallows
 “ and in the Earth which Moles cast up in the Spring.
 “ He then continues, That tho’ the Air and Water a-
 “ bound with it in some degree, yet that it is not there
 “ to be had in any Proportion answerable to the Charge
 “ in getting it : And that tho’ the Earth must necessa-
 “ rily have great Quantities generated in or infused into
 “ it, yet that in these Temperate Climates of *Europe*, it
 “ is no sooner dilated or dissolved by Rain-Water, or the
 “ Moisture of the Earth, but it is immediately applied to
 “ the Production or Nutriment of some Plant, Insect,
 “ Stone or Mineral, so that the Artist will find as little
 “ of it in the Earth to serve his Turn, as he could in
 “ the Air or in the Water.

He says therefore (in which he exactly concurs with
 our Author) “ That the only Places where it is to be
 “ found in any Plenty in these Northern Countries, are
 “ Stables, Pigeon-Houses, Cellars, Barns, Ware-Houses,
 “ and generally speaking in any Place which is covered
 “ from the Rain, which would dissolve it, and make it
 “ vegetate, as also from the Sun which rarifies it, and
 “ causes it to be exhaled into the Air. In short, he
 “ says, that he was assured by an experienced Workman,
 “ that no Place yields *Peter* in such abundance as the
 “ Earth in Churches, were it not an Impiety to disturb
 “ the Ashes of our Ancestors in that Sacred Depository ;
 “ and in this he agrees perfectly with what our Author
 “ says concerning the Desarts of *Podolia*, in *Chap. II.* of
 “ *Book II.*

“ But even in this Case the Earth must be of good
 “ Mold, and the better the Mold is, the more *Peter* is
 “ produced ; for in clayish or sandy Earth, little or none
 “ is found : And the freer Ingress the Air has the bet-
 “ ter, so that the Sun be excluded : But if the Earth be
 “ in

“ in itself never so good, if it be removed and laid upon
 “ a Brick or Boarded Floor, it will not be so rich in *Peter*,
 “ as if it had free Communication with the Exhalations
 “ of the lower Parts of the Earth.

“ In any Place qualified as is above premised (he says)
 “ you cannot miss of good Store of *Peter*, if it has not
 “ been drawn out in some Years before, which you will
 “ quickly find after you have digged the first Spade-full
 “ of Earth, by laying a little of it on the End of your
 “ Tongue, and if it tastes a little Bitter, you may assure
 “ yourself of good Store of Mineral (as they used formerly
 “ to call *Salt-peter*) ----- If the Ground be good, it
 “ continues Rich to six or eight Foot deep, and some-
 “ times but not often to Ten.

“ After the *Salt-peter* is extracted, if the Earth be laid
 “ Wet in the same Place again, it will be twenty Years
 “ ere any considerable Quantity grow there of it; but if
 “ the Earth be well dried, it will come in Twelve or
 “ Fourteen: And if the dried Earth be mixed with Store
 “ of Pigeon's Dung, and mellow Horse Dung, and then
 “ tempered with Urine (as was usual before we were sup-
 “ plied with *Peter* from *India*) it will be fit to dig up in
 “ five or six Years. If Water be cast upon Ground
 “ which is fit to dig for *Peter*, it will only sink the Mi-
 “ neral deeper into the Earth; but he that shall throw
 “ Soap-suds on it will destroy the *Peter* (as the Workmen
 “ have a Tradition) and it very well deserves a farther
 “ Inquiry.

He concludes, “ That the Generality of Authors are
 “ of Opinion that *Salt-peter* and the Way of drawing it
 “ out of the Earth, is a Modern Invention; but whether
 “ it was originally owing to Chance, or to the Sagacity
 “ of some great Wit, is as unknown as the Time it was
 “ discovered. But (he says) it seems to have many Years
 “ preceded the Invention of *Gun-powder*, which by the
 “ *Germans* is ascribed to *Constantine Aulitzer*, or *Berthold*

The TRANSLATOR'S PREFACE.

“ *Schwartz*, a Monk of *Friburgh*; which in all Probabi-
 “ lity was not long discovered when the Inventor (as *Po-*
 “ *lydore Virgil* tells us) taught the Use of *Guns* to the
 “ *Venetians* at the Battle of *Fossa Claudia*, when they ob-
 “ tained that notable Victory over the *Genoese*, Anno
 “ 1380. For there is mention made both of *Saltpeter*
 “ and *Aqua Fortis* in the Writings of *Geber*, a *Spanish*
 “ *Moor*, and an *Alchymist*; but at what time he lived is
 “ unknown; tho’ it is certain he lived some Hundreds of
 “ Years before *Raimund Lully*, who about the Year
 “ 1333 published some of his Books, where he treats of
 “ *Saltpeter* and *Aqua Fortis*. In fine, Mr. *Henshaw* says,
 “ it is no ill Conjecture of *Maierus*, That the foresaid
 “ Monk being a skilful *Alchymist*, had a Design to draw
 “ a higher Spirit from *Peter* than the common *Aqua For-*
 “ *tis*, and that he might the better open the Body of
 “ *Saltpeter*, he ground it with *Sulphur* and *Charcoal*, by
 “ which Composure he soon became the Inventor of *Gun-*
 “ *powder*.”

Thus far Mr. *Henshaw* concerning the History of *Saltpeter*; and I hope that what I have here transcribed, will prove acceptable to the curious *Pyrobalist*, especially if he never met with it before; and if he has, I doubt not but he will be of Opinion, that I have not done amiss in presenting it to the Perusal of many, who perhaps might never otherwise have seen it; or at least I flatter myself every one will acknowledge, that this curious Piece could never have been as it were revived upon a more proper Occasion than the Present; since it may serve to clear up some Things, and confirm others, which are to be found in the following *Work*; which it will not only do, but also compleat what *Casimir* has attempted upon this Subject.

As for Mr. *Henshaw*'s Manner of Making and Refining of *Saltpeter*, I shall only say, that it is in the main the same with what you will find in this Treatise with reference to that Matter.

Thus

Thus we see that what is almost universally held to be the very Basis and Generation of Nutriment, has by the restless and prying Curiosity of Mankind been perverted into the most fatal Instrument of Death and Destruction that has ever been discovered.

To conclude; you will observe, in perusing this *Work*, That our Author proposed to publish a *Second Part* of it, to supply what is wanting in this; but it seems, that either the Shortness of his Days, or the Multiplicity of his Business would not permit him to effect it: Wherefore I am to acquaint you, that what our Author has promised only, will be amply supplied by a GENTLEMAN, in every Respect qualified for so Great and Useful an *Undertaking*; and that you may soon expect such a Continuation of this Subject, as will (allowing for the many Improvements resulting from the Experience of the last *Wars*) more than answer all the Views of our Author with reference to the *Great Art* discussed in the following Sheets.



THE CONTENTS.

BOOK I.

Concerning the CALIBRE SCALE.

- Chap. I. **T**HE Arithmetical Construction of the Calibre Scale. Page 2
- Chap. II. *The Geometrical Construction of the Calibre Scale.* 9
- Chap. III. *The Mechanical Construction of the Calibre Scale.* 11
- Appendix. *A certain easy Method of Constructing the Calibre Scale.* 16
- Chap. IV. *A Method to find and transpose, or set off the Diameters of Bullets upon the Calibre Scale, whose Weights are less than 1 Pound, the Diameter of a Bullet of 1 Pound being first given.* 17
- Chap. V. *A Method to find the Diameter of a Bullet of one Pound by the Diameter of another Bullet weighing several Pounds.* 18
- Chap. VI. *A Method to find the Solidity of all sorts of Bullets, whether in Cubical Inches, or any other known Measure.* 21
- Chap. VII. *A Method to find by Numbers the Diameter of a Bullet of an unknown Bigness by the Diameter of a Bullet of one Pound made of the same Metal.* 22
- Chap. VIII. *The Method to examine the Truth or Exactness of the Calibre Scale, and of its particular Use in Pyrotechnics.* 23
- Chap. IX. *Of the Mutual Ratio of Metals and Minerals between themselves, or how to find by the Weight and Magnitude of any Metallic Body the Weight and Magnitude of another. Moreover how to set off the Diameters of Bullets made of several sorts of Metals and Minerals, &c. upon the Calibre Scale.* 25

The C O N T E N T S.

Chap. X. <i>Of Weights; their Difference, and Co-equation, or Equality to one another.</i>	Page 31
Chap. XI. <i>Of Weighing Instruments.</i>	45
Chap. XII. <i>The Ancient and Modern Liquid and Dry Measures carefully reduc'd to the Weights.</i>	52
Chap. XIII. <i>Of Long Measure, or the Mensuration of Space.</i>	75

B O O K II.

Concerning the Things which are commonly used in Pyrotechnics, or Artificial Fireworks.

Chap. I. <i>Of the Origin of Saltpeter; its Nature and Operations.</i>	83
Chap. II. <i>The Method of preparing Saltpeter from a Salnitrous Earth.</i>	90
Chap. III. <i>How to clarify or refine Saltpeter.</i>	94
Chap. IV. <i>How to reduce Saltpeter to a Flower.</i>	95
Chap. V. <i>The manner of preparing Saltpeter with the Flower of Wall.</i>	ibid.
Chap. VI. <i>How to prepare Salprotic, or Pulvis Fulminans.</i>	96
Chap. VII. <i>How to prove the Goodness of Saltpeter.</i>	97
Chap. VIII. <i>The true Method of purifying Saltpeter, and of separating from it all noxious and superfluous Matter; such as common Salt, Vitriol, Allum, and all gross and viscous Humours.</i>	98
Chap. IX. <i>How to purifie common Sulphur.</i>	ibid.
Chap. X. <i>How to reduce Saltpeter to an Oil.</i>	99
Chap. XI. <i>How to prepare Oil of Sulphur.</i>	100
Chap. XII. <i>The Method of preparing a Mixture of Oil of Sulphur, with Oil Saltpeter.</i>	101
Chap. XIII. <i>How to prepare Charcoal or Small-Coal for the Use of Gun-powder, and for other Uses in Pyrotechnics.</i>	ibid.
Chap. XIV. <i>How to prepare Pulvis Pyrius, or Gun-powder.</i>	102
Chap. XV. <i>How to make Gun-powder of several Colours.</i>	106
	Chap.

The C O N T E N T S.

Chap. XVI. <i>Of Silent Powder.</i>	Page 107
Chap. XVII. <i>How to prove the Goodness of Gun-powder.</i>	108
Chap. XVIII. <i>How to fortifie weakened Powder, and to restore that which is damaged in its first Vigour.</i>	110
Chap. XIX. <i>Of Buildings and Magazines for the preserving of Gun-powder, together with several Observations on the stowing, and keeping it secure from Fire, Moisture, &c. to the end that it may remain entire, and in the full Possession of its first Vigour.</i>	111
Chap. XX. <i>Of the Properties and particular Offices of each Ingredient concerned in the Composition and Preparation of Gun-powder.</i>	116
Chap. XXI. <i>Of Aurum Fulminans or Saffron of Gold — taken from the Royal Chymistry of Ofvaldus Crolius.</i>	118
Chap. XXII. <i>Of the Preparation of Flowers of Benjamin.</i>	120
Chap. XXIII. <i>How to prepare Camphire.</i>	121
Chap. XXIV. <i>Of Water of Sal Armoniac.</i>	123
Chap. XXV. <i>Of a certain Artificial Water, which burns upon the Palm of the Hand without doing any Hurt.</i>	ibid.
Chap. XXVI. <i>How to prepare the common Sort of Match.</i>	ibid.
Chap. XXVII. <i>How to prepare Match or Fire-Rope, which will neither smoke nor yield any ungrateful Scent.</i>	124
Chap. XXVIII. <i>The Manner of preparing Pyrotechnic Sponges.</i>	125
Chap. XXIX. <i>How to prepare several sorts of Quick Match for Artificial Fireworks.</i>	ibid.
Chap. XXX. <i>How to prepare Lutum Sapientiz or Lute.</i>	126
Chap. XXXI. <i>Some Excellent and Approved Medicines and Antidotes against Burns by Gun-powder, Sulphur, Hot Iron, Melted Lead, &c.</i>	127
Chap. XXXII. <i>Of a certain new Invention for measuring Gun-powder, Saltpeter, Sulphur and Charcoal; together with a Searce, and several other Things requisite in the Preparation of these Ingredients.</i>	128

The C O N T E N T S.

B O O K III. Of R O C K E T S.

Chap. I. <i>Of small and middling Rocket-Moulds.</i>	Page 131
Chap. II. <i>Of great Rocket-Moulds.</i>	133
Chap. III. <i>Of several Instruments for Making, Choaking and Driving all Sorts of Rockets.</i>	138
Chap. IV. <i>How to mix the Ingredients, and prepare Compositions for all Sorts of Rockets.</i>	145
Chap. V. <i>Of the Boring of Rockets, and several Instruments proper for that Work.</i>	151
Chap. VI. <i>Of Sky-Rockets that mount up with their Sticks.</i>	155
Chap. VII. <i>Of Sky-Rockets that mount up without Sticks.</i>	161
Chap. VIII. <i>Of Water-Rockets, or such as Burn and Swim upon the Water.</i>	162
Chap. IX. <i>Of Rockets that run upon Lines or Ropes.</i>	164
Chap. X. <i>Of the several Defects of Rockets. How to avoid them: Together with what ought be observed in the right Construction of them.</i>	166

B O O K IV. PART I.

Of RECREATIVE FIRE GLOBES or BALLS.

Chap. I. <i>Of Aquatic Globes, or such as Burn and Swim upon the Water.</i>	174
Corollary I. <i>Of Odoriferous, or Perfumed Water-Balls.</i>	181
Corol. II. <i>Of the Compositions for Water-Globes or Balls, which burn as well upon the Water as in it.</i>	182
Corol. III. <i>Of the Due and Proper Weight of each Water-Globe.</i>	186
Chap. II. <i>Of Recreative Globes that leap and bound upon Horizontal Planes.</i>	193
Chap.	

The C O N T E N T S.

Chap. III. <i>Of Recreative Aerial Globes which are projected from a Mortar-Piece.</i>	Page 195
Corol. I. <i>Of Shining or Light-Balls, such as are commonly used at Bonfires, which the Germans call Lichtkugel.</i>	200
Corol. II. <i>Of Pyrotechnic Stars and Sparks, called by the Germans Sternveuer and Veuerputzen.</i>	201
Corol. III. <i>Of the most certain Method for Projecting Recreative Globes from a Mortar: Of the Quantity of Powder requisite for that Purpose: And of the Chambers to receive it.</i>	202
Corol. IV. <i>Of Recreative Petards or Crackers.</i>	207

PART II. of BOOK IV.

Which treats of Fire-Globes; or Balls prepared for Military Uses.

Chap. I. <i>Of Hand-Grenado's.</i>	209
Corol. <i>How to Throw or Deliver Hand-Grenado's.</i>	213
Chap. II. <i>Of Bombs and Grenado's that are usually projected from Mortar-Pieces.</i>	223
Chap. III. <i>Of Grenado's that are commonly called Blind.</i>	237
Chap. IV. <i>Of Grenado's that are shot from large Cannon.</i>	238
Chap. V. <i>Of Fire-Balls, which the Latins call Globi Incendiarii, or Igniti, the Italians Palle di Fuoco, the Germans Ernst and Fewer Kugelen, the French Boulet a Feu, the Flemings Vyer Ballen, and the Poles Ogniste Kule.</i>	245
Corol. I. <i>Of the several Shapes that may be given to the Pyrotechnical Projectiles; which of them are the best adapted to receive the Impressions of a moving Force, and to retain their Motion after it is once communicated.</i>	257
Corol. II. <i>Of several Sorts of Pyrotechnic Petards or Crackers prepared for various Military Uses.</i>	270
Corol. III. <i>Of the several Sorts of Lacings, Mattings, and Ligatures of Fire-Balls, and the Terms futable to each of them.</i>	271

The C O N T E N T S.

Chap. VI. <i>Of a Wooden Ball filled with Hand-Grenado's, or a Thundering Ball.</i>	Page 272
Chap. VII. <i>Of a Globe or Ball composed by several others.</i>	273
Chap. VIII. <i>Of Fire-Rain.</i>	274
Chap. IX. <i>Of Light Balls.</i>	284
Chap. X. <i>Of Smoke Balls, which the Germans call Dampf and Blend Kugelen.</i>	287
Chap. XI. <i>Of Poisoned Balls.</i>	288
Chap. XII. <i>Of Stink-Balls.</i>	296
Chap. XIII. <i>Of a Ball, which Fire-Workers call a Death's-Head.</i>	299
Chap. XIV. <i>Of a Ball commonly called the Pyrobolist's Valet or Attendant.</i>	ibid.
Chap. XV. <i>Of the Pyrotechnic Manipulus or Bundle.</i>	300
Chap. XVI. <i>Of certain Pyrotechnic Balls which may be privately hid, and so ordered as to perform their Effects at certain Prefixed Periods of Time.</i>	301
Chap. XVII. <i>Of Red-hot Balls.</i>	303
Chap. XVIII. <i>Of Pyrotechnic Hail, by which are meant Cafe Shot, or Cartouch Shot, Partridge Shot and Grape Shot.</i>	306
Chap. XIX. <i>Of several Sorts of Chain and Bar-Shot, &c.</i>	307

B O O K V.

Which treats of several Warlike Machines fixed and moveable, Bodies of Fire, and other Pyrotechnic Arms, as well for War as Recreation. 309

P A R T I.

Which treats of Recreative Machines, Masses or Bodies Fixed and Projectile, and Arms Artificial and Pyrotechnical.

Chap. I. <i>Of Artificial Shields and Bucklers.</i>	313
Chap. II. <i>Of Fire-Cutlasses.</i>	317
Chap.	317

The C O N T E N T S.

Chap. III. <i>Of an Artificial Hanger or Dagger.</i>	Page 318
Chap. IV. <i>Of Artificial Swords.</i>	ibid.
Chap. V. <i>Of Fire-Poles or Rods.</i>	319
Chap. VI. <i>Of Fire-Wheels.</i>	ibid.
Chap. VII. <i>Of Artificial Clubs or Maces.</i>	322
Chap. VIII. <i>Of the Fire-Staff or Stiek.</i>	323
Chap. IX. <i>Of the Fire-Cup.</i>	324
Chap. X. <i>Of Artificial Cafes or Tubes.</i>	325
Chap. XI. <i>Of several Recreative Pyrotechnical Machines and Engines, composed of Rockets, Crackers, Globes, Wheels, Bucklers, Clubs, Symetars, Swords, Poles, Staves, Tubes or Cafes, and all such like Artificial Fires.</i>	333
<i>Of the Thematism, Decorum, or Gracefulness which is to be observed in the Ordering of our Recreative Pyrotechnical Machines.</i>	334
<i>Of the Oeconomy, or Distribution of Artificial Works, in Recreative Machines, and of several other Things relating to the same Subject.</i>	373

PART II. of BOOK V.

Which Treats of *Serious or Military Fireworks*, whether *Fixed*, or *Projectile*.

Chap. I. <i>Of Fire Ollæ, or Pots of all Sorts, Powder Flasks, Bottles, Chests, &c.</i>	382
Chap. II. <i>Of Fire-Crowns and Garlands, which the Germans call Pech, and Sturm Krantzen.</i>	385
Chap. III. <i>Of Fire-Hoops or Artificial Spheres.</i>	387
Chap. IV. <i>Of Artificial Cylinders.</i>	389
Chap. V. <i>Of Fire-Sacks.</i>	392
Chap. VI. <i>Of Artificial Tuns and Barrels.</i>	393
Chap. VII. <i>Of Pyrotechnic Flambeaus or Torches.</i>	396
Chap. VIII. <i>Of Fire-Arrows or Darts.</i>	398
Chap. IX. <i>Of Fire-Lances or Pikes.</i>	401
Chap. X. <i>Of Military Fire-Cafes.</i>	403

ERRATA

E R R A T A.

Page 10 Line 27, for which will cut read which must cur. p. 12 l. 22, for least read left. p. 16 l. 20, for Fig. 8. read Fig. 6. p. 17 l. 24, for Cube 31 read Cube of 31. p. 23, 4 lines from the Bottom, for Vent read Windage. p. 24 l. 1. read the same. p. 38 l. 8, for Quality read Equality. p. 50 l. 28, for Rhomboides read Rhombus. p. 58 l. 8, for 52 Pounds read 72 Pounds, Ibid. l. 29, for MODUS read MODIUS. p. 61 l. 24, for $\frac{1}{2}$ read $\frac{1}{4}$. p. 65 l. 10, for Corpinus read Cophinus. p. 74 l. 24, for Cochlearii read Cochlearia. p. 81 l. 7 from the Bottom, dele that is, a Day's Journey and Form of a Field. p. 84. l. 8 from the Bottom, for Herrurian Field read Tuscany. p. 90 l. 24, for lay read lye. p. 96 l. 7, for Stapula read Spatula. p. 98 l. 6, for of common Salt of Verdigrease read of common Salt; 1 Pound of Verdigrease. p. 104 l. 9 from the Bottom, for I shall silently read I cannot silently. p. 121 l. 8, for White-Wine Vinegar read Spirit of White-Wine Vinegar. p. 126 l. 7, for burn them to that degree that they may read burnt to that degree that it may. p. 138 l. 20, for $\frac{1}{2}$ read $\frac{1}{4}$. p. 141 in the Margin, for 39 read 38. p. 160 l. ult. for Product read Sum. p. 190 l. 18, for $\frac{1}{2}$ read $\frac{1}{4}$. p. 256 l. 12, for Poliorcticæon read Poliorcticæon. p. 262 l. 19, for to read by. p. 268 l. 30, for alternaly read alternately. p. 292 l. 30, for Tin read Pewter. p. 297 l. 10, for rotten read rotten. p. 354 l. 29, for which were Games instituted by the Emperor Gallienus to be kept every ten Years, read which were celebrated by the Emperor Gallienus after a very extraordinary Manner. p. 363 l. 17, for his read this. p. 398 l. 23, for where read were.

OMISSIONS and MISTAKES in the PLATES.

In Plate D, Fig. 17, there is a W wanting at the Angle over-against the outward Entrance of the Ichnographic Figure. In Plate G, there is a P wanting over-against E in Fig. 48. In Plate H there are two 75, the lowermost of which should be 76.

DIRECTIONS to the BOOK-BINDER.

Plate.	Facing	Page.	Plate.	Facing	Page.
A	Facing	32	M	Facing	246
B	Facing	44	N	Facing	272
C	Facing	114	O	Facing	318
D	Facing	134	P	Facing	330
E	Facing	142	Q	Facing	374
F	Facing	154	R	Facing	378
G	Facing	160	S	Facing	Ibid.
H	Facing	166	T	Facing	Ibid.
I	Facing	178	U	Facing	Ibid.
K	Facing	198	W	Facing	384
L	Facing	230	X	Facing	404





OF THE
GREAT ART
OF
ARTILLERY.

PART *the* FIRST.

BOOK I.

Concerning the CALIBRE SCALE.

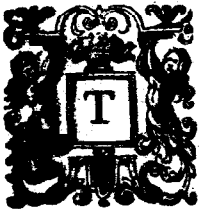

THE first and principal Instrument used in *Pyrotechnicks*, or *Artificial Fireworks*, which we call the *Calibre Scale*, (according to the universal Term amongst all *Pyrotechnicians*, or *Artificial Fireworkers*, as well *Spaniards* and *French* as *Italians*) is called by the *Germans*, *Maßtaab* or *Vischer-taab*; by the *Flemmings*, *Talstock*; but much more properly by the *Latins*, *Virga*, or rather *Regula Sphærometrica*; and which, in Derivation from them, we will call in *English* the *Sphærometric Rod* or *Scale*. We must conceive no other thing by the different Appellations above recited, than a certain Instrument or kind of Ruler, which has a near Resemblance to a Parallelopiped Prism, or rather to the *Frustum* of a square Pyramid, which ought to be made of some Metal, or hard Wood, that will not easily bend; upon one of whose Superficies is a right Line, divided into unequal parts in a Stereometrical or Cubical Proportion, and nicely adjusted to determine and examine the Weights of all Iron Bullets by their Diameters. This *Scale* or Ruler accordingly shews the Diameters of all Bullets made of the abovementioned

B

Metal,

2 *Of the Great Art of ARTILLERY.*

Metal, from the Diameter of a Bullet of one Pound, or from that of a *Lot* or Half an Ounce, *ad infinitum*; that is, as far as the Length of the Line can admit of. In like manner upon the Second and Third Superficies of this *Scale*, you have the Diameters for Bullets of Lead, or Stone, &c. of different Gravities, by which you may determine the Weights of Bullets made of those Materials. The Fourth and last Superficies of this Instrument, shews the Measure of the *Rbynland Foot*, or (as some will have it) the *Old Roman Foot*, which is divided into twelve *Unciæ* or Inches, and with this we may measure not only all *Pyrotechnick* Bodies; but likewise all Sorts of Superficies, Planes, and Lines.

Having thus described the *Calibre Scale*, it is but reasonable that we should proceed to shew the different Methods by which it may be constructed; and also its particular Use in *Artillery*; of all which in the Order and Method following.

C H A P. I.

The Arithmetical Construction of the Calibre Scale.

THERE are many and different Methods used by almost all Arithmeticians and Geometricians, as well Theoretical as Practical, and even among the greatest Part of Mechanicks, in the Construction of the Stereometric or Cubical Line (from whence our *Calibre Scale* takes its Original) or whenever they would divide any Line into proportional Parts according to the Cubical *Ratio*. In order to do this Arithmetically, you need only double, treble, &c. the first *Cube* as often as you think fit; and extract the *Roots* after the Manner I shall shew in the Sequel: But by the way I must observe that those who practise this Science, as well as the rest of the Mechanicks, have taken it into their Heads to avoid this Operation; because of the Necessity of extracting the *Cube Root*, which is a little irksome and difficult, and content themselves with dividing their Lines into a Cubical Proportion by the Assistance of Tables, that have before been calculated by other Arithmeticians, which they freely make use of, in all their Operations. But since it is of no small Importance to such as would be perfect in this Art, to have a Knowledge of this Method; we shall here give some very succinct Rules, relating to the *Cube Roots*, together with the Manner of making Stereometrical Tables; by means of which we shall easily construct our *Calibre Scale*.

A Brief Method of extracting the Cube Root comprehended under the following Rules.

Arithmeticians term that a Cubical Number, which is made and produced by any Number multiplied into itself, and then the same Number multiplied by the Product. As for Example; if the Number Ten be multiplied into itself it will produce a Hundred, which if it be multiplied again by Ten it will give a Thousand, which last Number we call a Cube; and Ten, which was the original Number, we call the Cube Root; this being once well understood, you will find it very easy to extract the Cube Root of any Number whatsoever, if you attentively observe the following Directions.

First, you must have in your Eye a Table of the Nine first Cubes and their Roots, which may be easily form'd by multiplying the Nine simple *Integers* cubically, as demonstrated in the following Table:

Roots.	Cubes.
1 - - - - -	1
2 - - - - -	8
3 - - - - -	27
4 - - - - -	64
5 - - - - -	125
6 - - - - -	216
7 - - - - -	343
8 - - - - -	512
9 - - - - -	729

2. In order to extract the Cube Root of any Number, as suppose 160|103|007; divide off every three Figures, of this Number, as you see above, beginning from the Right-hand towards the Left; which done, look into the Table of Cubes, for the greatest Cube under 160, which you will find to be 125; therefore 5 being the Root of 125, set down 5 in the Quotient, and subtract 125, its Cube from 160, and you will have a Remainder of 35, to which you must bring down the next Cube, (*viz.*) 103.

3. To find the next Figure of your Quotient, you must form a Divisor; which is always done by trebling the Square of the Quotient; as for Example; 5 being multiplied by 5, makes 25, which is the Square of 5, which Square being multiplied by 3, produces 75; and this last Number is the Triple Square of the Quotient, which is to serve for a Divisor: With this Divisor divide the Resolvend 35103, excepting (the two last Figures, *viz.*) 03, and you will have 4 for the second Figure of the Quotient.

4. Then to find the Number which is to be subtracted from the abovesaid Resolvend, you must set down in a Corner by itself, the Triple Square (*viz.*) 75, with two Dots to the Right of it, instead of Cyphers,

4 *Of the Great Art of ARTILLERY.*

Cyphers, after this manner 75 .. ; then multiply 5, the first Figure of the Quotient, by 4, the last Figure found, and you will have 20, which being multiplied by 3 will give 60, which Number must be set under 75 .. one Place farther towards the Left Hand (*viz.*) the Cypher in 60 under the first Dot ; then square the last Figure found (*viz.*) 4, and it will give 16 ; which must be set under the two other Numbers, so that the last Figure 6 may stand under the last Dot ; which done, add these three Numbers together, and they will make 8116, which must be multiplied by the last Figure of the Quotient (*viz.*) 4, and the Product will be 32464, which being subtracted from the Resolvend 35103, the Remainder will be 2639, to which you must bring down the next Cube, (*viz.*) 007, which being annexed to the said Remainder you will have 2639007 for a new Resolvend.

5. You must proceed upon every Operation by finding a new Divisor ; (which is always the Triple of the Square of the Quotient) therefore square 54, the Number now in the Quotient, and you will have 2916, which Sum being trebled will give 8748, which must be your new Divisor ; and upon enquiring how often this new Divisor is contained in your new Resolvend (excepting always the two last Figures) you will find it to be three Times ; set then 3 in the Quotient, and proceed to find a new Subtrahend, in the same Manner as we have already directed, and which you must repeat as often as a new Figure is to be set in the Quotient : This will be found to be 2639007, which being subtracted from the Resolvend, you will have no Remainder, as will appear by the Work itself ; the whole Process of which is as follows ;

160 103 007 (543 Root.			
	125		
<hr/>			
75)	35103	Resolvend.	5
	32464	Subtrahend.	4
	<hr/>		<hr/>
8748)	2639,007	Second Resolvend.	20
	2639,007	Second Subtrahend.	3
	<hr/>		<hr/>
	0000 000		16
			<hr/>
			60
			<hr/>
			5
			5
			<hr/>
			25
			3
			<hr/>
			75 .. Triple Squared
			60. Quotient.
			16
			<hr/>
			8116
			4
			<hr/>
			32464

54 <hr style="width: 100%;"/> 3		54 <hr style="width: 100%;"/> 54
162	3	216
<hr style="width: 100%;"/> 3	<hr style="width: 100%;"/> 3	<hr style="width: 100%;"/> 270
486	9	2916
		<hr style="width: 100%;"/> 3
		8748..
		486.
		9
		<hr style="width: 100%;"/> 879669
		<hr style="width: 100%;"/> 3
		<hr style="width: 100%;"/> 2639007

Triple Squared
Quotient.

Observe here that the above Number being a perfect Cube its Root is exactly 543; but in case you should (as it often happens) be obliged to extract the Cube Root from an Irrational or Surd, or a Number that is not a complete Cube, you may approach it as near as possible by adding Ternaries of Cyphers to the said Surd Number; and when the Cube Root of it and the additional Cyphers is extracted, you will have the Roots and Decimal Parts near enough for any Business; as may be seen by the following Example:

37 864 125 ,000(335,7				
27	3	33	335	335
<hr style="width: 100%;"/>	3	33	335	7
10864				
8937	9	99	1675	2345
<hr style="width: 100%;"/>	3	99	1005	3
1927125			1005	
1658375	27..	1089	<hr style="width: 100%;"/>	7035
<hr style="width: 100%;"/>	27.	3	112225	
268750,000	9		3	
236165 293		3267..		
<hr style="width: 100%;"/>	2979	495.	336675..	
32584 707	3	25	7035.	
			49	
	8937	331675	<hr style="width: 100%;"/>	
		5	33737899	
			7	
		1658375	<hr style="width: 100%;"/>	
			236165293	

Thus the Cube Root of the above Number is found to be 335,7, and a large Remainder: Now to prove the Work; cube the said Cube
C Root,

6 *Of the Great Art of ARTILLERY.*

Root, and to the Cube of it add the Remainder, and if the Work is right, the Sum or Aggregate will be equal to the Sum from whence the Root was extracted ; as for Example :

$$\begin{array}{r}
 3357 \\
 3357 \\
 \hline
 23499 \\
 16785 \\
 10071 \\
 10071 \\
 \hline
 11269449 \\
 3357 \\
 \hline
 78886143 \\
 56347245 \\
 33808347 \\
 33808347 \\
 \hline
 37831540293 \text{ Cube.} \\
 32584707 \text{ Remainder.} \\
 \hline
 37864125000 \text{ Sum or Aggregate from which the} \\
 \text{Root was extracted.}
 \end{array}$$

Now as it will often happen (as I have already said) that you must extract the Cube Root from some given Number that will not answer exactly; I have (to prevent your throwing away time) thought proper to give you some Rules, by means of which you may readily know all those Numbers that will not answer exactly to a Cubical Extraction.

1. All Numbers ending with two or more Cyphers, and which cannot be measured by the Ternary Number, that is, that cannot be exactly divided by three, cannot have their Roots perfectly Cubical, such as these, 3400, 62800, 453000.

2. All Numbers ending with 2, or 4, and whose last Figure but one is even, cannot be exactly Cubic, such as, 3522, 62864.

3. Every Number ending with 4 or 8, and whose last Figure but one is not a Cypher or an even Number, cannot be punctually Cubic; as for Example; 456174, 110038.

4. Such Numbers as cannot be exactly divided by 9, are never perfectly Cubic; therefore the following Number 12000 is not so; for it being divided by 9, you will have a Remainder of 3.

Let this little that we have now said concerning the Extraction of the Cube Root, and a Knowledge of the Cubic Numbers, satisfy you for the present; the Use of it shall be evidently explain'd in the Sequel of our Practice, and subsequent Operations.

Now,

Of the Great Art of ARTILLERY. 7

Now if you would make a Table of Cubes with their Roots from Unity, or the Diameter of one Pound, *ad infinitum*; you may first assume any Number that you shall think fit to serve as a Root, which being multiplied cubically by itself, will produce the first cubical Number; and its Root, or the Number you shall have assumed for its Cube Root, must be first set down in this Table. As for Example; if you take the Number 100 for a Root, and it be multiplied cubically into itself, your first Cube will be 1,000,000, of which 100 being the Root, it must be set down in your Table as the first Root.

If you would extract the Cube Root from double this Cube; you must double it, and you will have 2,000,000, from whence, if you extract the Cube Root, you will find it to be 125; which will be the second Root of your Table, and the second Number. If you would know the Root of this Cube when trebled, quadrupled, and so on; first, treble or quadruple it, or increase it, *ad Infinitum*, and from those Numbers (as you go along) extract the Cube Roots, and place them in a regular Order in your Table; joining in a Column upon one Side of them, the ascending or increasing Numbers in a natural Order, from Unity as far as you please. This is the Method I observed in the Construction of the following Table, the Assistance of which, if you please to accept, in forming the *Calibre Scale*, I must tell you; that it is first necessary that you should have the Diameter of a Bullet of one Pound, made of the same Metal with those Bullets which you would form your *Calibre Scale* to measure. For Example; if you would prepare an Instrument or *Calibre Scale*, to calibre Iron Bullets; divide the Diameter of an Iron Bullet of one Pound, actually taken from an Iron Bullet of that weight (I shall, in the Sequel, show how that is to be done) into as many equal Parts, as the first Root of the Table contains Unities; as here, in our Table, the first Root contains 100 Unities; therefore divide the Diameter of an Iron Bullet of one Pound, into an hundred equal Parts, which you may readily perform by the Help of the Parallelogram, or Diagonal Scale, *Fig. 1*. Having then with a Pair of Compasses taken from that Scale all the Parts, according as they are expressed in the Table of Cube Roots; transpose the Diameters of your Bullets upon the *Calibre Scale*: As thus; if you take 100 for the Diameter of an Iron Bullet of one Pound, you must allow 125 of the same Parts for the Diameter of a Bullet of two Pounds; that is, you must add 25 Parts to the first Diameter. Again, for the Diameter of a Bullet of three Pounds, you must take 144 Parts, or add 44 Parts to the first Diameter; and in the same manner you may transpose the Diameters of all other Bullets upon the *Calibre Scale*. This gradual Increase of the Diameters and their respective Circumferences in the *Ratio* of Solids, is very plain, and to be easily conceived by *Fig. 2*, in which the first Circle denotes the Circumference of a Bullet, whose Diameter is as the first Root, and its solid Contents as the first Cube.

The

8 *Of the Great Art of ARTILLERY.*

The second Circle is the Circumference of a Bullet whose Diameter is as the second Root, and its Solidity of double the first Cube. In the same manner you are to infer, with regard to the other Circumferences in the same Fig. as to their Diameters and Solid Contents.

Whatever we have here said of Iron Bullets, may be said of those also that are made of Lead, Stone, &c. which may be calibred by the very same Rules; so that you may, with equal Ease, construct a *Calibre Scale* for that Purpose.

We have given you a Representation of this Instrument in Fig. 3. upon one of whose Surfaces you will see the Diameters of Iron Bullets accurately marked out, and upon the other the Diameters of Lead Balls.

A Table of Cubes and Cube Roots in a natural Order from Unity upwards—the first Cube being supposed to contain 1,000,000 of Parts.

Order of the Cubes.	Roots.	Order of the Cubes.	Roots.	Order of the Cubes.	Roots.	Order of the Cubes.	Roots.
1	100	26	296	51	371	76	424
2	125	27	300	52	373	77	425
3	144	28	304	53	376	78	427
4	159	29	307	54	378	79	429
5	171	30	311	55	380	80	431
6	182	31	314	56	382	81	433
7	191	32	317	57	385	82	434
8	200	33	321	58	387	83	436
9	208	34	324	59	389	84	438
10	215	35	327	60	391	85	440
11	222	36	330	61	394	86	441
12	229	37	333	62	396	87	443
13	235	38	336	63	398	88	445
14	241	39	339	64	400	89	446
15	247	40	342	65	402	90	448
16	252	41	345	66	404	91	450
17	257	42	348	67	406	92	451
18	262	43	350	68	408	93	453
19	267	44	353	69	410	94	455
20	271	45	356	70	412	95	456
21	276	46	358	71	414	96	458
22	280	47	361	72	416	97	459
23	284	48	363	73	418	98	461
24	288	49	366	74	420	99	463
25	292	50	368	75	422	100	464

C H A P. II.

The Geometrical Construction of the Calibre Scale.

IT is absolutely necessary that you should have the Side of the first Cube, or the Diameter of a Bullet of one Pound, made of the same Metal, for the particular Use of which you would construct your *Calibre Scale*. For Example; in *Fig. 4*, let there be given the Line A, B, for the Diameter of an Iron Bullet of one Pound; then, in order to find the Side of double the Cube, that is, the Diameter of a Bullet of two Pounds, double the Line A, B, or extend it to twice its Length, which suppose to be the Line A, D; then find out two mean Proportionals between the single Line A, B, and the double Line A, D, and there will be one of them found (*viz.*) the least of the two mean Proportionals, which is D, E, which will be the Side of the double Cube, or the Diameter of an Iron Bullet of two Pounds; in this manner you must proceed to find out the Diameters of all other Bullets, that is, by increasing the Length of your First Diameter as far as is proper or requisite, and then finding out two mean Proportionals between the Line expressing the Length of your first Diameter, and the increased Line.

The most experienced Geometricians, however, assure us, that never any one yet hath invented the true Method of finding out two mean Proportionals Geometrically, between two other given ones; notwithstanding that many of them have greatly labour'd, and employ'd much of their Time in search of this Secret: The thing, indeed, is extremely difficult, inasmuch as we can produce no *Ratio* (I mean, that is truly Geometrical) to double, treble, &c. or encrease a Cube, *ad Infinitum*, by means of a common Scale and Compass only, as is usually done, when we would augment the Proportion of any kind of Planes; which, however, cannot possibly be done, 'till you have previously found out two mean Proportionals by a nice Research.

A vast many Geometricians, as well ancient as modern, have done their utmost to solve this very authentick Problem, which indeed is of the greatest Use in all mechanical Matters; and have even endeavoured to demonstrate it, as a Plane and Linear Figure (though there are those who place this in the Rank of Problems relating to Solids) by certain mixed Lines artfully drawn, and by simple Lines immediately proceeding from a Plane, as are all Right Lines and Curves. Amongst which *Nicomedes* has endeavour'd to demonstrate it by a Conchile Line, *Dioclesian* by a Cissoidea or Hederacea, *Menæchmus* by Conic Sections, and many others by the Parabola; but *Eratosthenes*, *Sporus*, and *Plato*, have aimed at it by Right Lines and Curves; and even *Pappus*, *Hero*, *Apolonius*,

10 *Of the Great Art of ARTILLERY.*

Ionius, Pergæus, Philo Bisantius, Orontius, Villalpandus, Clavius, and many other Geometricians, have laboured to do it by several other Methods: But whatever they have said or done upon this Head; I think it unbecoming of me to examine too scrupulously into the Works of those illustrious Men, to whom the Republick of Learning is so greatly indebted; and much less would it become me to pass a Judgment upon them, or to determine too rashly concerning their Thoughts upon this Subject. I shall only say, that it is acknowledged and declared by the greatest Geometricians, that it is impossible to increase the Cube by Planes; and this I affirm from the very Confession of those who have so closely fought after it. But this is not sufficient for us to condemn their Inventions, reject their laborious Efforts, or look upon them as repugnant to right Reason and Truth: No; on the contrary we ought to continue the Use of them, until a more happy Age shall produce such as are preferable and more perfect. In such a variety of Practice as has been used to this End; I have pitched upon one Method only, which I here present for your Use in increasing the Cube, and to find out two mean Proportionals in a continued Order, and which, I believe, will be sufficient, in the right and proper treating of Pyrotechnical Matters.

Let there then be found two mean Proportionals in a continued Order, between the two above-mentioned Lines A, B, and A, D; let them be first placed at right Angles to one another, and let the Parallelogram A, B, C, D, be constituted upon them, and let A, B, and A, D, be continued *ad Infinitum*; then the Diagonals B, D, and A, C, being drawn, let H be placed at the Intersection of them; and apply a Ruler to the Point C, which will cut the Lines A, B, and A, D, continued *ad Infinitum*, in the Points E, and F, in such a manner that H, E, and H, F, may be found equal: This done you will have D, E, and B, F, for mean Proportionals continued between the given Lines A, B, and A, D; for they will be as C, D, that is, as A, B, is to D, E, and as B, C, that is, as A, D, to B, F.

I purposely omit the other Methods, the greatest Part of which you may find, as well in the Authors above quoted, as in *Marius Bottinus's Treasury of Mathematical Philosophy*, lately published at *Bologna*, wherein he endeavours, by all Means, to prove, that the ancient Geometricians, as well as some of the most modern (whose Names he mentions) have not only discovered the true, plain, and perfect Method of finding out two mean Proportionals to any two given; but that they have also illustrated it by Geometrical Demonstrations; so that nothing can be further desired upon this Head. But let us attend to what he says in this Translation of a Passage in his *Latin Treatise*, (*viz.*) *Therefore what we have formerly said in Apiar. III. Prob. I. in relation to the Conchoid of Nicomedes, in a doubtful and cautious manner, we do now boldly affirm (in order to shew that the best Part of the Geometrical Philosophy, concern-*

Of the Great Art of ARTILLERY. II

ing Solids, is truly established) that two mean Proportionals have been long ago Geometrically and Demonstratively found. For to say nothing of the Inventions of the rest of the Ancients, and only mention one, of which there are Footsteps still remaining amongst us; the two mean Proportionals found by Nicomedes by help of the Conchile Line have that Geometrical Certainty, than which no greater can be desired, in the Geometrical Demonstration of any Problem — And a little lower — Upon which Account there remains no Reason to doubt, but that the Geometrical Method of finding two mean Proportionals was invented long ago, as likewise that the Truth and Certainty of all Stereometrical Problems arising from two Proportionals are Geometrically demonstrated.

But we have found an easy Contrivance by means of Instruments, whereby to find not only two mean Proportionals to two others given, but in any Number of Proportionals required; and by that Invention we may be able at last to reduce a given Solid to a Cube, contain'd within Æquidistant Lines, as also to change one Figure into another Equal to it or bigger, still keeping its Likeness; wherefore it is not to be doubted but Altars and Edifices may be doubled by such an Instrument, and also one may refer to the Cube the Measures of Dry and Liquid Substances, as of Bushels, &c. The Contents of which Measures are known by the Sides of the Vessels, and in a Word, the Knowledge of this Question is useful to those, who would make bigger Sorts of such Machines as are used for throwing of Darts, Stones, or Iron Balls; for in those Cases, it is necessary that all the parts of the Machine should be encreased in a certain Proportion, as well as the Things to be thrown, and this cannot be done without the Invention of a mean Proportional.

C H A P. III.

The Mechanical Construction of the Calibre Scale.

OF so great a Number of *Pyrotechnicians*, or Artificial Fireworkers that we see in our Days, we shall not find one (pardon me for the Expression) that does not desire the good Opinion of the World, and to be esteemed a good Practitioner: But at the same time they choose to be such in Appearance, rather than in Reality; and only outwardly affect to appear very knowing in their Profession: Though by the way a thorough Knowledge in it is not to be acquired in peaceable Times, in the Chimney Corner, amidst the softening Effeminacies of the Body, Serenity of the Mind, or by ignoble Sloth; but on the contrary by the insupportable Fatigues of the Field, at the imminent Danger of Life, and the Sweat of the Brow. I have even known some of them who scorning the plain and vulgar Denomination of *Pyrotechnicians*; but glorying

12 *Of the Great Art of ARTILLERY.*

rying in the Title of Fire Engineers in the Military Capacity, which the *Flemmings* call *Feld-Fewerwercker*, have thought it beneath them (they being destitute of Theoretical Principles) to concern themselves with any of the Theorems of *Archimedes* or *Euclid*, or any other famous Author, or even to produce any Demonstrations to prove and confirm the Rules of their Art. Hence comes this new Pseudomechanical Science entirely unknown to the greatest part of past Ages, and whose chief and most general Axiom is, *Perturbare confusè & nihil ad rem omnia agere*; that is, to put every thing into the utmost Confusion, and never do any thing as it should be. Consider now, whether the Burthen of this Self-sufficient Mother can be successful? Or whether the Fruit of such a Science must not be strangely uncouth? Every Day you have irreparable Errours and Defects, as well in the Construction of Warlike Machines, as in the Preparation and artful Management, or handling of them. The *Fireworks* on serious and necessary Occasions, as well as those exhibited upon Publick Rejoicings, are for the most part prejudicial to the Prince, and evidently dangerous to the Lives of those who work in the Composition of them, as well as to those of the Spectators who behold them. How greatly are those to be pitied, who are ignorant in the Principles of true Mathematicks! Hear what * *Paulus Guldenus* saith, in an Arithmetical Problem, where he speaks to this Effect in his *Latin* Treatise. *Least therefore our Mathematicians should become unworthy of that Title; but that on the contrary, they may lift up their Heads out of the Ocean of Ignorance, and apply themselves to the Study of the most noble of those Sciences; we have in the beginning of our Lectures, looked upon the Mathematicks as a most powerful Queen with her numerous Household of subject Sciences; whose Order, Subdivisions, Definitions, with their Differences and Distinctions, we have fully and clearly explained in our Lectures; and in order to imprint them the more strongly in the Memory, we have in a very agreeable pleasing Method collected them upon a small Sheet of Paper, not for the Use of our Times only, but as an acceptable Present to Posterity likewise. We have laid down Arithmetick and Euclid's Geometry as the Basis or Foundation, of the Mathematical Superstructure; without which it is impossible for any one, though he were to live and study to the Age of Nestor, to attain any true and solid Knowledge in that Science. From a Want of those first Rudiments proceed that Obscurity and Chimerical Uncertainty, that Labyrinth of Errours, and that vast Chaos of Ignorance. Hence it is, that Men are so far mistaken as to be ignorant of what they do know, and think they know what they are ignorant in. Hence so many Mechanical Mathematicians, unskilful Surveyors, so many Exbauflers of Wine Casks, instead of Gaugers: Hence so many Bankrupt Merchants, unfortunate Captains in War, false Architects, and Artificers, who rather promise to construct new Machines for great Purposes, such as*

* *Paulus Guldenus* Lib. IV. Centro. Cap. 7.

*raising Water to great Heights, and for removing vast Bodies, than perfect them. Hence so many Engineers without Ingenuity, disappointed Searchers after the perpetual Motion, so many unhappy Squarers of the Circle, and all the Blunders of Architects. In fine, hence the Man that begins to build, and knows not how to finish or compleat what he has begun. But I would by no means have it thought, by what I have here said, that I would in the least depreciate the Military Practice, to which alone I more particularly applied myself: I am only grieved to see this illustrious Science of Pyrotechnicks dishonoured even by those who profess it; (I mean Practitioners without Foundation;) who have despoiled it of its ancient Glory, and stripped it of all its most beautiful Ornaments, bestowed on it by its first Inventors; and still keep it separated, and as it were, forcibly torn from the Bosom of its lawful Mother the *Mathematicks*, as a Science alien to and independent of it; and have crowded it in amongst the most illiberal Arts, and the most Mechanical Operations.*

In Truth, I could wish, that entirely banishing this new Mechanical Science; I say, I could wish, that no one would by any means suffer a Novice or Apprentice to take any Work in hand, till he is first well grounded in the Principles of *Arithmetick* and *Geometry*; from whence we might expect, that this great Art would, in a little time, retrieve its Original Lustre; and consequently that the Invention of so many ridiculous (I should choose to say, costly and dangerous) Machines, which those Master Workmen have exhibited, would be justly exploded, and we might at leisure taste the delicious Fruits of this Science.

But let us resumé the thread of our Subject, and since we have engaged ourselves to give in this Chapter the Methods of Constructing the *Calibre Scale* mechanically; you must first know, that there is nothing so easy as all these Inventions; but if you would at any time try, whether or no they can bear the Test of Geometrical Proportion, which is the true Touchstone of all such things, you will infallibly find them incumbered with Falsities and Errours, and will perceive that it is entirely impossible to demonstrate them according to the Rules of Art. We must own however, that some of them have been found to be right; but they have not yet been demonstrated Geometrically; all the rest are false, or at least doubtful; which we are nevertheless obliged to bear with patiently, because they do not seem repugnant to common Sense. For my part, I never commended or approved of them, inasmuch as I never acknowledged them to be grounded upon the least Foundation of Geometrical Truth. Now this Art consists in one Point, from whence if you deviate to the Right Hand, or Left, forwards, or backwards, whether you carry the Foot all round the Circumference or not, you will find your Operations defective, and yourself far enough off from what you sought. Therefore I cannot advise any Body, to make use of this Method. However, that I may not conceal any Article from the Reader, who is desirous of knowing every thing, I shall display the

14 *Of the Great Art of ARTILLERY.*

Practice which those Artists we have been speaking of, value at so high a Rate: But I shall here dwell upon two Examples of it only, which seem to me the most Geometrically proportionate, and better founded than the rest.

E X A M P L E I.

The Perpendicular, C, K, being drawn *ad infinitum*; from the Point C towards K; in B let the Diameter of a Bullet of one Pound C, B, be placed; then from the Center A, describe the Circle B, D, E, C; and let the Diameter B, C, be divided into three equal Parts, C, I; I, H; and H, B; and let a third be set off upon the Periphery of the Circle from B to F, and from F to E upon one Side of the Diameter, and on the other Side from the same Point B to G, and from G to D. Now, if from C you draw through the Points D, and E, the right Lines C, L, and C, M, *ad infinitum*, you will have your Figure adjusted; by which you must increase the first Cube, or the first Diameter of a Bullet after this manner. Having taken the Diameter C, B; from C sweep the Segment of a Circle 1. 1. then taking the distance between the Points 1. 1. from the same Point C describe the Arch or Segment 2. 2. and the distance of the Points 2. 2. from the Point C upon all the three Lines, will be the Side of the double Cube, or the Diameter of a Bullet of 2 Pounds. Again, take the transversal Distance of the Points 2. and 1. which is marked with a prickd Line, and describe the Arch 3. 3. and the distance between the Point C, and the Points 3 upon each of the three Lines will be the Diameter of a Bullet of three Pounds. In like manner take the distance of the Points 2. 2. upon the Lines C, M, and C, L, and from C describe the Segment 4. 4. and the distance between the Points marked with 4 and the Point C will be the Diameter of a Bullet of four Pounds. This Method you must pursue in finding out the Diameters of other Bullets: that is, by adding always the lesser uneven Number, to the greater even one, and reciprocally the lesser even Number to the greater uneven one; or by taking the transversal Lines drawn betwixt them; and alternately as you go along taking the Lines directly extending from one and the same Number, as may be seen in *Fig. 5.* where we have carried on the Progression to the Number 20; but as this is self-evident, it would be Time ill spent to say any more of it.

E X A M P L E II.

Let the Diameter of a Bullet of one Pound be divided into 4 equal Parts, and let $\frac{1}{4}$ be added to the first Diameter, and you will have the Diameter of a Bullet of 2 Pounds; then divide the Diameter of a Bullet of 2 Pounds into 7 equal Parts, and add $\frac{1}{7}$ to the Diameter of a Bullet of 2 Pounds, and you will have the Diameter of a 3 Pounder. And

Of the Great Art of ARTILLERY. 15

in this Manner and Proportion, you must increase the Number immediately preceding, to find the Diameters of all other Bullets: Thus you may continue it to what Number you please. As for me, I have carried it on no further than the Number 10, to save my Time and Labour; but I have continued it in another Method to 100, ascending decimally by 10 and 10 at a time, and always dividing by 4, as will be plainly shewn by the following Table. As to the Numbers between each 10, you are to proceed with them in the same manner as you did with the first 9 Numbers. Moreover if you divide the Hundreds in the same manner, you will have the Hundredths in the same Proportion as the Decimals and Unities.

Diameters of Bullets.	Divided into Parts.	Parts added to the Diameters.	Make the Diameters of Bullets weighing lb.
1	4	$\frac{1}{4}$	2
2	7	$\frac{1}{7}$	3
3	10	$\frac{1}{10}$	4
4	13	$\frac{1}{13}$	5
5	16	$\frac{1}{16}$	6
6	19	$\frac{1}{19}$	7
7	22	$\frac{1}{22}$	8
8	25	$\frac{1}{25}$	9
9	28	$\frac{1}{28}$	10
10	4	$\frac{1}{4}$	20
20	4	$\frac{1}{4}$	30
30	4	$\frac{1}{4}$	40
40	4	$\frac{1}{4}$	50
50	4	$\frac{1}{4}$	60
60	4	$\frac{1}{4}$	70
70	4	$\frac{1}{4}$	80
80	4	$\frac{1}{4}$	90
90	4	$\frac{1}{4}$	100
100	4	$\frac{1}{4}$	200

We have call'd these two above given Examples Mechanical; because they are neither demonstrable nor artificial; they may, however, in some respect be called Geometrical; by reason of the great Resemblance they have to Geometrical Problems, that are perform'd with Instruments; but nevertheless, these are not purely Geometrical, though they may, in some sort, be called Mathematical; they may, at least, be ranked amongst those that are worked by Scale and Compass only; those two Instruments being immediately founded upon the *Postulata*, that is, upon the Right Line and the Circle; the same may be said of all those Instruments that are made by Scale and Compass; but in the main they are merely Mechanical.

APPENDIX.

A certain easy Method of Constructing the Calibre Scale.

NOTwithstanding that the two Methods we have already given (not reckoning the Mechanical one) have nothing difficult attending them, it being by them plainly demonstrated, that the first and fundamental Origin of our *Scale* is drawn from Axioms, and the most certain Truths of Arithmetick and Geometry; yet as they are a little perplexed and disagreeable, because of the Extraction of the Cube Root, and the Necessity of finding out two mean Proportionals; I cannot present you with a more easy Direction, than by recommending the Sector to you, provided it be faithfully adjusted; for as upon that Instrument you have the Stereometric Line, exactly divided into Sides of Cubes, or rather the Diameters of Bullets, it is derived from Arithmetical Calculation. Therefore having, with a Pair of common Compasses, taken the Diameter of a Bullet of one Pound, made of any Metal whatsoever, let it be apply'd transversally upon the Cubical Line from 1. to 1. and thus, without removing the Instrument from its Position, take in like manner the Diameters of all other Balls or Bullets, and transpose them upon the *Calibre Scale*; by this means you will have your Scale constructed by once opening the Sector: (See *Fig. 8.*) But if you have not the Convenience of a Sector, you may, instead of that, make Use of *Fig. 7.* with regard to which you may proceed after the following Manner.

Let the Line A, B, be drawn *ad Infinitum*, upon which, from the Point A towards B, set off the Sides of all the Cubes taken from our Table of Cube Roots in *Chap. I.* which you may do by any Scale you please, from Unity to what Number you think fit. Then take the Diameter of a Bullet of one Pound, made of the same Metal with those Bullets you intend to measure; and fixing one Foot of the Compass at the Point 1. describe an Arch or Segment of a Circle with the other, and let its Tangent A, C, be continued *ad Infinitum*. The Distance between the Divisions of the Line A, B, and the Tangent, will be the Diameters of Bullets *ad Infinitum*, increasing continually according to the Progression of Numbers, following one another in a natural Order, and successively exceeding one another by one Pound Weight at a time.

CHAP. IV.

A Method to find and transpose, or set off the Diameters of Bullets upon the Calibre Scale, whose Weights are less than one Pound, the Diameter of a Bullet of one Pound being first given.

SUPPOSE then that the Diameter of a Bullet of one Pound (as we have already observ'd in a foregoing Chapter) be divided into 100 Parts; let it be cubed, and you will have 1,000,000, divide this by 32, (which is the Number of *Loths*, or half Ounces in a Pound) and you will have 31250 in the Quotient, from which, if you extract the Cube Root, it will be found to be 31. Take off then with your Compasses that Number of Parts from the Scale above-mentioned *Fig. i.* and set them upon your *Calibre Scale* from A to B, and you will have the Diameter of a Bullet of one *Loth*, or half an Ounce. Now, in order to find the Diameters of Bullets, whose Weight consists of several *Loths*, or half Ounces, you need only double, treble, &c. the Cube of the Diameter 31, which was last found, and then extract the Cube Roots of your increased Numbers, in the same manner as was done to find out the Diameters of Bullets weighing several Pounds. This is the Method I followed in the composing of the following Table, from whence you may take the Diameters of half Ounces and transpose them upon your *Calibre Scale*, by the help of the Diagonal Scale beforementioned. Furthermore, if you would have the Diameters of the Aliquot Parts of an half Ounce (*viz.*) the $\frac{1}{2}$, the $\frac{1}{3}$, the $\frac{1}{4}$, the $\frac{1}{5}$, divide the Cube 31 by 2, 4, 8, 16, and extract the Cube Root from the Quotient of each Division, and you will have the Diameters of the Aliquot Parts of an half Ounce, as may be seen by the following Table.

Order of the Cubes.	Roots.
$\frac{1}{16}$	12
$\frac{1}{8}$	15
$\frac{1}{4}$	19
$\frac{1}{2}$	24
1	31
2	39
3	44
4	49
5	53
6	56
7	59
8	61
10	66
12	70
16	78
18	81
20	84
24	89
30	96

ANOTHER METHOD.

Take the Diameter of a Bullet of 2 Pounds, and divide the same into 4 Parts, and $\frac{1}{4}$ will be the Diameter of a Bullet of half an Ounce; take
 F again

18 *Of the Great Art of ARTILLERY.*

again the Diameter of a Bullet of 4 Pound, and divide it into 4 Parts, and $\frac{1}{4}$ will be the Diameter of a Bullet of an Ounce. Thus you may go on with encreasing your Diameters 2 Pound at a time, and dividing them into 4 equal Parts, and $\frac{1}{4}$ will be the Diameters of Bullets, encreasing half an Ounce each time in weight.

Thus you may continue till you come to 64 Pound, for the $\frac{1}{4}$ of the Diameter of a Bullet of that weight is exactly the Diameter of a Bullet of one Pound.

If you would work this by the Compass of Proportion or Sector, transpose the Diameter of one Pound, taken with the common Compasses, transversely upon the Line of Cubes, (or, which is the same thing, upon the Line of Solids) between 32 and 32, and without altering the Instrument, add together all the transversal Distances between 1 and 1, 2 and 2, 3 and 3, and so on to 31, and you will have the Diameters of Bullets of all the half Ounces contained in a Pound. If you do not make use of the Sector, the *Fig. 7.* I gave you in the foregoing Chapter will serve your Purpose, provided that by means of any Scale of equal Parts you set off upon the bottom Line 32 Stereometrical Spaces from A towards B, each distinguished with Points and Numbers; and if you go on still farther, you must take care to carry on your Operation in the Method I have already laid down.

CHAP. V.

A Method to find the Diameter of a Bullet of one Pound by the Diameter of another Bullet weighing several Pounds.

ARITHMETICALLY.

THE Method we shall take in this Operation will differ but little from what we have said in the foregoing Chapter, except that the Diameter of the given Bullet may be divided into a certain Number of Parts, as for Example into 100, 200, 300, or else into 10, 20, 30, &c. more or less, but you will work upon a more certain Foundation the larger the Number it is divided into. You need not here stick to the Observance of the 100 Parts of the Diameter of one Pound, as we have already divided it, which you will perceive by what follows. Suppose now for Example you have an Iron Bullet, or one made of any other Metal, of any Size and Weight whatever; and suppose you would by Means of this, know the Diameter of a Bullet of one Pound, made of the same Metal with itself. In *Fig. 8.* let A, C, be the Diameter of an Iron Bullet A, B, C, D, (which you may take with two small gnomonical Instruments, elevated upon any Plane, or with the

Of the Great Art of ARTILLERY. 19

Calibre Compaffes, &c.) divide then the Diameter into a certain Number of equal Parts; let us divide it in this Example into 100 equal Parts, as we have elfewhere done with regard to the Diameter of a Bullet of one Pound; this done, divide the Cube of 100 by the Weight of the Bullet: Set the Cafe that the Ball be a 24 Pounder; you muft divide the Cube of 100 by 24, and extract the Cube Root from the Quotient of your Division, and you will have the Number of Parts which conftitute the Diameter of a Bullet of one Pound, as may be feen by the following Operation:

lb	Cube.		
24)	1,000,000	(41,666 (34 Root	3 3
	96 ····	27 ·	4 3
	.40	14666	12 9
	24	12304	3 3
	160	2362 Remainder.	36 27 ..
	144		360
	.160		16
	144		3076
	.160		4
	144		12304
	16.		

Obferve here that if from the Diameter of a given Bullet, you would know the Diameter of a 2 Pounder, you muft divide the Cube of the Diametrical Parts by half the Weight of the given Bullet; again, if you would have the Diameter of a 3 Pound Ball, you muft divide by $\frac{2}{3}$ of the Weight of the given Bullet; in fhort, if you would from this like-wife have the Diameter of a 4 Pound Ball, you muft divide the Cube of the Number of Parts, into which the Diameter of the given Ball is divided by $\frac{1}{4}$, of its Weight; which done, extract the Cube Roots from your Quotients, and you will have what you required.

G E O M E T R I C A L L Y .

Let the right Line A, B, *Fig. 9.* be drawn *ad infinitum*, and upon the Point A, let fall the perpendicular A, C, upon which fet off the Diameter of the given Bullet from A to D; at the fame time it is neceffary that you fhould know the Weight of the given Bullet, which if it does not exceed 8 Pounds, divide the Diameter into two equal Parts, and then fubdivide the upper Section into 100 equal Parts: But if the Ball exceeds the Weight of 8 Pounds, you muft divide the Diameters of all Bullets

Bullets between 8 and 27 into 3 equal Parts, observing to subdivide the uppermost third, into 100 equal Parts as before. Again, if the Weight of the Bullet exceeds 27 Pounds, you must divide the Diameters of all Bullets between the last mentioned Number and 64 into 4 equal Parts; if it exceeds 64 into 5, if 125 into 6, and if 216 into 7. And thus you must do successively whenever the Weight of a Bullet exceeds any cubical Number; that is, you must divide its Diameter into as many equal Parts as the Root of the subsequent Cube contains Unities, and always subdivide the uppermost Section into 100 smaller Parts. This being supposed, let the right Line F, G, be drawn parallel to the Base from I, that cuts off the lower Division of the Line A, D, and then look for the Cube Root inserted over-against the Weight of the Ball in the Stereometric Table, which having found, take the Diameter of it with a pair of Compasses. It being very evident, that each of the Sections into which the whole Diameter is divided, contains 100 Parts equal to those into which the upper Section is subdivided, inasmuch as they three are all equal within themselves; it will follow, that you must reckon from A towards C as many Parts as the Number in the Table of Cube Roots over-against the Weight of your Bullet contains Unities. Then fixing one of the Feet of your Compasses at the Point of the Number found, with the other describe an Arch of a Circle, intersecting the Base of the *Figure*; and from the Point of Intersection draw a right Line to the Point of the Number found, which must necessarily cut the Line F, G, parallel to the Base; then take the distance between the Points of one and the other Intersection; that is, from the Base to the other Line that is parallel to it, and you will have what you required.

In *Fig. 9.* Let A, D, be the Diameter of a Bullet of 10 Pounds: Now because this exceeds the Weight of a Bullet of 8 Pounds, its Diameter is divided into 3 equal Parts, which are A, F, F, K, and K, D, and its upper Section is subdivided into 100 equal Parts. From the Point F which intersects the lower Third of the Diameter, draw the Line F, G, parallel to the Base A, B; this done, look for the Number in the Table of Cube Roots that is over-against 10, the Weight of your Bullet, and you will find it to be 215. Supposing now that A, F, and F, K, contain each 100 Parts; if you reckon 215 Parts from A, towards C, you will find the Point L, from whence if an Arch of a Circle be described whose Semi-Diameter is equal to the Diameter of the given Bullet, it will intersect the Base A, B, in the Point H; and a right Line being produced from H, to L, it will in like manner intersect the Line F, G, in the Point I, and thus the distance between the Points H and I, is the Diameter of an Iron Bullet of one Pound, which was required.

Observe here that if the Weight of the given Bullet answers exactly to a Cubical Number, you must in that Case divide its Diameter into as many first and principal Parts, as the Root of it contains Unities; for one of the Parts of a Diameter thus divided will be the Diameter of a
Bullet

Bullet of one Pound: But all this being extremely easy, it needs no further Illustration.

This may be performed with much more readines with the Sector, by putting the Diameter of the given Bullet between the Points and Numbers that expresse the Weight of it upon the Stereometrical Line, and then upon the same Line taking the distance between the Points 1 and 1, which distance will be the Diameter of a Bullet of one Pound.

With the same ease and to the same purpose you may use the *Fig. 7.* described in the third Chapter, if you rightly conceive how to put it in practice.

C H A P. VI.

A Method to find the Solidity of all sorts of Bullets, whether in Cubical Inches, or any other known Measure.

WE shall meet with no great difficulty in solving this Proposition, if we take Notice of the Demonstrations of *Christopher Clavius* in *Lib. V. Folio 263.* of his *Practical Geometry*, concerning the Cube and the Sphere, where he tells us that the Cube of the Diameter of a given Bullet is to its Solidity as 21 to 11; for Example, let the Diameter of a Bullet be 6 *Unciæ* or Inches of the *Rbynland* Foot, the Cube of 6 is 216; if now by the Rule of Three you say, as 21 is to 11 so is 216 the Cube of the Diameter to the Solidity; you will have 113, which is the Number of Cubic Inches contained in the given Bullet. Observe here, that if you extract the Cube Root of the Number denoting the Solidity of the Bullet, you will have the Side of a Cube that will be equal to the given Bullet in Weight and Solidity.

Furthermore, if by a given Solidity of any Body, you would have the Diameter of a Globe or Ball equal to that Body in Weight and Solidity, you must invert the foregoing Analogy, and let it be as 11 to 21; for in that *Ratio* will the Solidity given, be to the Cube of the Diameter of the Ball required. In the above Example you have a Solidity given of 113 Cubic Inches, which if you apply thus to the Rule of Three, and say; as 11 is to 21 so is 113 the given Solidity to the Cube of the Diameter required, you will have 215, now the Cube Root of this Number (*viz.*) $5 \frac{1}{2}$ will be the Diameter of a Bullet equal in Weight to the given Solidity.

Again; you may know the Weight of any Bullet by its own Solidity given in Cubic Inches, without the *Calibre Scale* or any Mechanical Invention whatsoever. You must first know (what I believe is very well known amongst *Pyrotechnicians*) that the Bullet whose Diameter is 4

22 *Of the Great Art of ARTILLERY.*

Unciæ or Inches of the *Rbynland* Foot weighs 8 Pounds of Iron: This being granted, and the Solid Contents of any Bullet being given, you may solve it by the Rule of Three after this Manner (*viz.*) as the Cube of the Diameter of 4 *Unciæ* or Inches is to the Weight of 8 Pounds, so is the Cube of any other Diameter determined by the same kind of Measure to its own Weight. Which may be easily conceived by the following Example:

$$64 : 8 :: 216$$

8

$$64 \overline{) 1728} \quad (27 \text{ Pounds of Iron.}$$

128

448

448

N. B. 64 is the Cube of 4,
and 216 the Cube of 6.

C H A P. VII.

A Method to find by Numbers the Diameter of a Bullet of an unknown Bigness by the Diameter of a Bullet of one Pound made of the same Metal.

THE Solution of this depends entirely upon the Rules laid down in the first *Chapter*, as we shall show in the following Example. Suppose now, you are asked how many *Unciæ* or Inches of the *Rbynland* Foot constitute the Diameter of an Iron Bullet weighing 1000 Pounds. In order to find this, multiply the Cube of the Diameter of a Ball of one Pound, by the Number of Pounds which the Bullet whose Diameter you seek for weighs, then extract the Cube Root from the Product, and your Question will be answered. As here in our Example the Diameter of an Iron Ball of one Pound is 2 *Unciæ* or Inches of the *Rbynland* Foot whose Cube is 8; now 1000, the Weight of the given Bullet, being multiplied by 8 it will produce 8000, of which 20 being the Cube Root, that Number is the Diameter of an Iron Bullet weighing 1000 Pounds; that is 20 *Unciæ* or Inches of the *Rbynland* Foot; which was required.

C H A P. VIII.

The Method to examine the Truth or Exactness of the Calibre Scale, and of its particular Use in Pyrotechnicks.

IT often happens that we dare not rely upon Instruments, that have been wrought and adjusted by the Hands of a Workman, and seldom make use of them till they have been thoroughly examined by us, as to their Exactness and Truth; for from a false or mistaken Construction of them, innumerable Errors and Absurdities arise, as daily Experience evinces. It will be then necessary that our *Calibre Scale* should undergo a strict Examination, whether it has been made by your self or an Instrument-maker; you may then adjust it after this manner. With a Pair of common Compasses take the Diameter of a Bullet of one Pound, which must be repeated as often as the Length of the Scale will permit, and upon the Points already engraved. Now this first Diameter will show all the Points that are distinguished or denominated by Cubical Numbers; for Example, being once taken it will extend to 1, which is the first Cube; the next time to 8, which is the second Cube; the third time to 27, which is the third Cube; the fourth time to 64, which is the fourth Cube; the fifth time to 125, and so on with regard to the rest. After the same manner, the length of the Diameter of 2 Pound will point at the Number 8 twice repeated, *viz.* to 16; and thrice taken, it will point at 27 twice repeated, that is to 54, and so on of the other Diameters, as will appear by the Table at the end of this Chapter; in which the Numbers that are under A, are primitive or original, by a Repetition of which are produced all those under B: Thus from the first Diameter these Numbers arise (*viz.*) 8, 27, 64, 125; and all the others that follow in that transversal Order, or in that Line. From the first Repetition of the second Diameter will arise 16, from the second 54, and so on of the rest. Your *Calibre Scale* having stood this Proof, you may safely make use of it. Now though its Uses are very various in *Pyrotechnicks*, yet its principal Business is to Calibre Cannon Bullets, and the Bores or Orifices of warlike Machines, such as are all Pieces of Ordnance, Mortars, Petards, &c. As for Example, let there be given a Cannon, whose Bore is as in the *Fig. 8.* A, B, C, D, let the Diameter of its Circumference be A, B, which having taken with a Pair of Compasses, transpose it to your Calibre Scale (having first allowed for the *Vent* of the Ball, as we shall observe hereafter) and one of the Feet will point out to some Number on your *Scale*, expressing the Weight of a Bullet of the same Diameter. As in our *Fig.* the Diameter B, E, (without reckoning A, E, which is

24 *Of the Great Art of ARTILLERY.*

the *Vent.* of the Ball) being applied to the *Calibre Scale*, prepared for calibring Iron Bullets, you will have the Number 2, which is the Diameter of a Bullet of 2 Pound, by which you will readily conclude, that the given Cannon carries a two Pound Ball. If you apply this same Diameter to the other Superficies of the *Scale*, where the Diameters of Lead are marked out, you will find some Number denoting the Weight of the same Bullet if it was made of Lead.

Observe here that if the Diameter of any Bullet being applied to the *Calibre Scale*, does not answer exactly to an Integer or Pound; but extends a little beyond it; you must know that the said Bullet is heavier than a Pound; now in order to find how much it exceeds it, take notice of the following Method. Let a certain Diameter extend somewhat beyond the Point 1 upon your *Calibre Scale*; then see how many Parts your Diameter is composed of, and likewise how many of the same Parts constitute the Diameter of a Bullet of 1 Pound. Let us set the Case here, that the Diameter of 1 Pound is divided into 100 equal Parts, and that the given Diameter contains 108 of the like Parts: From thence you will naturally infer, that the Weight of a Bullet of that Diameter, exceeds the Weight of a Bullet of 1 Pound, in the same Proportion as the Cube of 108 exceeds that of 100. Now to find out exactly how much the one weighs more than the other, you must reason after this manner by the Rule of Three: If 1,000,000 the Cube of 100 gives 32 half Ounces (or a Pound) how many will 1,259,712 (which is the Cube of 108) give? This being performed after the common way, it will come out about 40, which will be the Number of half Ounces that your Bullet weighs, and consequently it will be exactly 4 Ounces heavier than a Bullet of one Pound.

A	B	B	B	B	B	B	B	B	B
1	8	27	64	125	216	343	512	729	1000
2	16	54	128	250	432	686	1024	1458	2000
3	24	81	192	375	648	1029	1536	2187	
4	32	108	256	500	864	1372	2048		
5	40	135	320	625	1080	1715			
6	48	162	384	750	1296				
7	56	189	448	875					
8	64	216	512						
9	72	243							
10	80								

C H A P. IX.

Of the Mutual Ratio of Metals and Minerals between themselves, or how to find by the Weight and Magnitude of any Metallic Body the Weight and Magnitude of another. Moreover how to set off the Diameters of Bullets made of several sorts of Metals and Minerals, &c. upon the Calibre Scale.

SINCE in *Pyrotechnicks* not only Iron Bullets are used; but such also as are made of different Metals and Minerals, as Lead, Stone and the like; and as in meeting with Bodies made of various Substances, it frequently happens either through Necessity, or else to satisfy the Curiosity, that we would gladly know, by means of the given Weight or Magnitude of any Body, the *Ratio* of the Weight or Magnitude of other Bodies made of different Metals, or Materials; I could not omit obliging those who have a Genius or Inclination to *Pyrotechnicks*, by pointing out the Way for them to come at this piece of Knowledge, and that, by shewing them in this *Chapter* certain mutual *Ratios* and Properties of Metals and Minerals between one another; which I have here taken from the Works of the most learned and experienced Authors. However, I must beg of the Reader, that when he meets with these mutual Proportions of Metals in other Authors that vary a little from ours; I say, I must beg of him not to take it amiss, that we have stuck to the latest and newest Experiments; though we are far from aiming at a Diminution of the Authority of others; easily imagining that every one knows well enough (as *Matthias Berneggerus* says in his *Annotations upon the Treatise of Galileus de Galileis*) *That pure Metals, that is, such as, free from the Commixture of any other sort of Metal, do not so mutually agree, but that their Ratios are subject to some change, and that they weigh differently when of the same Kind. Thus Gold is found to be heavier or lighter than Gold, and Lead than Lead, according as they differ in Magnitude. Moreover, hammered Metal is heavier than that which is cast, its Parts being more closely compacted by being hammered than by being melted. Therefore in vain do you seek after this Perfection. The different Specific Gravity of Stones is much more considerable than that of Metals. Some of them are very porous, and called Sand Stones; other sorts of them are more solid, but those disagree greatly from one another in Weight. Moreover, the different ways of weighing certain grave or heavy Things, have a great Resemblance to Astronomical Observations, which almost always differ some Minutes or Seconds from one another.* Now as it is necessa-

26 *Of the Great Art of ARTILLERY.*

ry that you should know, in what manner the Learned have established certain Rules, and furnished us with infallible Experiments, to determine the different Specific Gravities of all Metals, and to facilitate the greatest Difficulties you might meet with in your Researches after a Certainty upon this Head, I shall subjoin what *Mersennus* (one of the greatest Mathematicians our Age has produced) says on this Subject in his Book of *Hydraulicks*, Prop. 47.

First then, I made Experiments upon Liquors by pouring them into Phials, which are the best the narrower their Necks are, and round the Neck you tie a Thread, or draw a Line that you may exactly fill the Bottle to the same height with different Liquors. I need not here mention, that you must dry the Bottle well every time, for fear the least drop of the Liquor used in a former Experiment by adhering to the Bottle, either within or without, should hinder you from exactly finding out the Specific Gravity of the Liquor you are trying; neither need I mention what has otherwise been said of Balances and Steel-yards, and of the Division of Weights in which the greatest Exactness is required.

But this Method is not convenient for weighing hard Bodies, such as are all Metals, except they be first melted, and I accordingly took care to melt them; but besides that all Metals do not fill the same Mould (as I shewed Prop. 8. Lib. IV. concerning Bells) and that some contain more Air than others, and that some are not to be melted without a good deal of difficulty, such as Copper and pure Brass; Stones and Wood cannot be melted at all; I therefore examined Metals after they had been drawn into fine Wire (as may be seen from the above-quoted Book of Harmony) which not giving me full Satisfaction, because of the various Size of the Wire, the first of it that passes through the Mould being thicker than what comes through afterwards, and since some Metals cannot be drawn into Wire no more than Wood or Stones, &c. I thought it necessary to think of some other way.

The third Method that I thought might have done was by getting Bodies made into Spheres, Cubes, and Parallelepipeds; but Stones, Metals, Wines, &c. cannot be shaped with a Plane or turned in a Lath; and therefore at last I find the best way to be, to weigh all solid Bodies with an exact Balance in Air or Water, or in each successively, to find the differences of their Weight. In Air the Liquors are to be examined and compared with Water, weighing them in the above-mentioned Bottle with a narrow Neck: But the rest of the Bodies being hard might like the Liquors be exactly weighed in Air, if they were equal in Bulk, or if the difference of their Bulk was known; but as their Figures are commonly different and irregular, nothing is more convenient or exact than weighing them in Water; and by comparing a Bulk of Water equal to them, to their Gravity, we may find out how much one Body is heavier than another, and if this be once reduced to a Table the whole Labour will be saved.

The same Author says, I remember Dunot a Geometrician was used to reduce all Metals to the Paris half Pint (or the English Pint) and supposing that

Of the Great Art of ARTILLERY. 27

that Measure of Water to weigh one Pound, he said that the following Metals were in this Proportion; (for Example) such a Measure of Iron would weigh 8 Pound, of Silver $10 \frac{1}{2}$ Pound, of Lead $11 \frac{1}{2}$ Pound, and Gold 19 Pound, and that a Leaden Ball whose Diameter was 1 Inch and 8 Lines weighed 1 Pound, but when he proposed to fill a Pint with melted Metals to find the just Weight of the rest, I dissuaded him from it; because I found that Moulds and Vessels are not equally filled by different Metals; and that some Metals are more full of little Vacuities (or Wind Holes, as the Smelters call them) than others.

It is here then that *Merfennus* shews us the mutual Proportions of Metals, which he has very accurately reduced to a Table, assuring us that Bodies of Metal of one and the same Magnitude, observe the following *Ratio* and Order, with respect to one another as to Weight; to which we have added the Proportions that Sulphur and Wood bear to the Metals,

Gold	- - - - -	100
Mercury	- - - - -	$71 \frac{1}{2}$
Lead	- - - - -	$60 \frac{1}{2}$
Silver	- - - - -	$51 \frac{1}{2}$
Copper	- - - - -	$47 \frac{1}{2}$
Brass mixed with <i>Lapis Calaminaris</i> .	-	45
Iron	- - - - -	42
Common Tinn	- - - - -	39
Pure Tinn	- - - - -	$38 \frac{1}{2}$
Loadstone	- - - - -	26
Marble	- - - - -	21
Stone	- - - - -	14
Chrystal	- - - - -	$12 \frac{1}{2}$
Sulphur	- - - - -	12
Water	- - - - -	$5 \frac{1}{2}$
Wine	- - - - -	$5 \frac{1}{2}$
Wax	- - - - -	5
Oil	- - - - -	4
Lime-Tree Wood	- - - - -	3

The particular and principal Use of this Table will be to shew, by the known Magnitude and Weight of any Bodies made of any of these Materials, the unknown Magnitude and Weights of any other Bodies made of the same; and likewise their mutual *Ratio's* with regard to Magnitude and Weight. If for Example you would know the mutual *Ratio* of the different Specific Gravities of Iron and Lead; that is, in what degree Lead is naturally heavier than Iron; (supposing their Bulk to be equal) you must look into the above Table, where you will see that the Weight of Lead is to the Weight of Iron, as $60 \frac{1}{2}$ is to 42.

This

28 *Of the Great Art of ARTILLERY.*

This being known you will easily solve this Problem, which is in truth a very excellent one, and perfectly necessary in *Pyrotechnicks*. To illustrate this, there is an Iron Cannon given whose Weight is 2000 Pound; now I demand how many Pounds of Brass would be requisite to make another Cannon of the same Size, in the same Form, and with all the same Ornaments and Embellishments with the given Cannon. In order to solve this, you must proceed in this manner, (*viz.*) Having from the above Table taken the Numbers expressing the *Ratios* of the two Metals; say, as 42 (the number expressing the Weight of Iron) is to 45, (the Number expressing the Weight of Brass mixed with *Lapis Calaminaris*) so is 2000 Pound, the Weight of the given Iron Cannon, to the Weight of the Brass one sought; this being performed, you will find, that the Weight of Brass mixed with *Lapis Calaminaris*, requisite to make a Cannon, like the given one, will be 2142 Pound and 27 *Lotbs*, or 13 $\frac{1}{2}$ Ounces, or thereabouts.

By inverting the Order of these *Ratios*, and by knowing the exact Dimensions of any Body, you will easily discover the Magnitude of any other Body, whose Magnitude is measured with the same Parts, and is also of equal Weight with the given or known Body, and of the same Form, though of different Bulk. For Example, let the Magnitude of an Iron Bullet of one Pound be known, whose Diameter is divided into 100 equal Parts; (as we have more than once observed;) by which you would know the Diameter of a Leaden Bullet of the same Weight. In order to do this, look for the *Ratios* of their Specific Gravities in the above Table, for as 60 $\frac{1}{2}$ is to 42, so will the Magnitude of an Iron Bullet be to the Magnitude of a Leaden Bullet of the same Weight.

Now in order to know the Number of equal Parts which the Diameters of one and the other Bullet ought to contain, I have inserted another Table which I have carefully calculated, by the help of the Table of Cube Roots in the first Chapter of this Book; and likewise by the Assistance of the mutual *Ratios* of the Specific Gravities, as in the above Table; in doing which we observed this Method. We multiplied the Root of the hundredth Cube, taken from the Stereometric Table, that is, 464, always by 100, and divided the Product 46400, by the Roots over-against the Numbers answering to the Specific Gravities of Metals with regard to Gold. For Example, to find the Number of Parts which constitute the Diameter of a Leaden Bullet, we divided the Product of our Multiplication abovementioned, (*viz.*) 46400, by the 60 $\frac{1}{2}$ Cube Root, (as in our forementioned Table of Roots) which is about 392; now the Quotient 118, is the Diameter of a Bullet of Lead of equal Weight with one made of Gold. By this Method we calculated the following Table, which if you please to make use of, let us to illustrate it; suppose that you want to find the Diameter of a Leaden Bullet of 1 Pound, and that you already have the Diameter of an Iron Bullet of the same Weight, divided into equal Parts, which

we

we will here (as well as we have elsewhere) suppose to be 100. This done, range the proportional Numbers of the two Metals in this manner by the Rule of Three (*viz.*) As the proportional Number of Iron (which in the Table is 133) is to the proportional Number of Lead (which in the same Table is 118) so are the 100 equal Parts, of which the Diameter of the Iron Bullet is composed, to the Parts of the Diameter of a Bullet of Lead of the same Weight with the Iron one; which was required.

Having worked this Analogy, you will have the Diameter of a Leaden Bullet consisting of $88\frac{2}{3}$ Parts of the same Bigness or Nature as the 100 Parts, into which the Diameter of an Iron Bullet is divided. Thus you are to proceed to find out the Diameters of Bullets, of the other Metals, but of equal Weight with one of Iron. In short, the Diameter of a Bullet made of any kind of Metal being known, you will have the Diameters of all the rest, by taking their respective Numbers from our Table of Proportions, and then working them by the Rule of Three. By what we have been saying, we shall readily come at all the Diameters that are usually found upon the *Calibre Scale*. Moreover we may not only have the Diameters of Globes or Bullets, but also all the Homologous Sides of any Bodies, as well regular as irregular (provided they are made of such Materials as are to be found in our Table) together with their mutual *Ratios* as to Magnitude, as may be conceived by the following Table. As for Example, let there be given a Cube of Wood, whose Weight is 10 Pound, and let it be required of you to make a Cube of Copper of the same Weight with the given one; to do this, divide one Side of the given Cube into a certain number of equal Parts; (but it may not be improper to tell you, that the more Parts you divide it into, the more exact will your Work be;) let us here suppose the Side of the given Cube to be divided into 60 equal Parts; then take their proportional Numbers from the following Table, and range them as usual in cases of the Rule of Three (*viz.*) as 309, the proportional Number of Wood, is to 128, the proportional Number of Copper, so is 60, the Number of Parts into which the Cube of Wood is divided, to the number of the same Parts requisite for the Side of a Cube of Copper, of the same Weight with the Cube of Wood which was given; from which there will arise this Number $24\frac{2}{3}$, which are the Number of Parts of the same Bigness, or Nature with those into which the Cube of Wood was divided, as are necessary for the Side of a Copper Cube, of the same Weight with the Wooden one.

What has now been done with regard to the Side of a Cube, as a regular Body, may be done with respect to the Homologous Sides of an irregular Body; and thus may you have the Magnitudes of *æquiponderant* Bodies, made of different Metals, such as Brass, Iron, &c. and all by the help of Models or Moulds, (to use the term in the *Proplastic Art*) such as the Moulds of all the Pyrotechnical Bodies, which are for

30 *Of the Great Art of ARTILLERY.*

the most part irregular, as all Cannons, Mortars, Petards, and such like Machines; whether they be made of Wood, Wax, Lead, or any other Metal or Mineral whatsoever. To conclude, we may easily come at a Knowledge of the Encrease or Augmentation of any Body, by such means as we have been speaking of; and by the assistance of the Table of Cube Roots given in the first Chapter; always observing that the given and required Body be exactly of the same Form. Concerning this Subject you may, if you please, have recourse to the 25th Problem in *Galileo's* Treatise of the *Sector*; wherein he teaches how to find out the same thing by an Instrument of his own Invention.

Observe here that we have not given the Proportion of mixed Metals to the others; it being very difficult to ascertain any Rules concerning it; because the Founders, and such like Workmen, have very various Methods of allaying, or mixing Metal when they cast Cannon, of which we shall speak more fully in another Place. We have, however, observed by Experience, that the Weight of a Metal mixed in such Proportion, as that in 100 Pound of Copper, there is 20 Pound of Brass mixed with *Lapis Calaminaris* (which the *Latins* called *Aurichalcum*, the *Germans* *Messing*, the *Poles* *Mofiad*, and we *Lattin*) and 10 Pound of Tinn; (an Allay which is esteemed the strongest, and is now in general use amongst the *European Nations*) comes the nearest in Weight to the Specific Gravity of Brass made with *Lapis Calaminaris*.

Diameters of Equiponderant Bullets, divided into equal Parts.

Gold	- - - - -	100
Mercury	- - - - -	111
Lead	- - - - -	118
Silver	- - - - -	122
Brass or Copper	- - - - -	128
Brass with <i>Lapis Calaminaris</i>	- - - - -	130
Iron	- - - - -	133
Common Tinn	- - - - -	136
Pure Tinn	- - - - -	137
Loadstone	- - - - -	156
Marble	- - - - -	168
Stone	- - - - -	192
Chrystal	- - - - -	201
Sulphur	- - - - -	202
Water	- - - - -	266
Wine	- - - - -	267
Wax	- - - - -	271
Oil	- - - - -	276
Lime-Tree Wood	- - - - -	309

we will here (as well as we have elsewhere) suppose to be 100. This done, range the proportional Numbers of the two Metals in this manner by the Rule of Three (*viz.*) As the proportional Number of Iron (which in the Table is 133) is to the proportional Number of Lead (which in the same Table is 118) so are the 100 equal Parts, of which the Diameter of the Iron Bullet is composed, to the Parts of the Diameter of a Bullet of Lead of the same Weight with the Iron one; which was required.

Having worked this Analogy, you will have the Diameter of a Leaden Bullet consisting of $88\frac{2}{3}$ Parts of the same Bigness or Nature as the 100 Parts, into which the Diameter of an Iron Bullet is divided. Thus you are to proceed to find out the Diameters of Bullets, of the other Metals, but of equal Weight with one of Iron. In short, the Diameter of a Bullet made of any kind of Metal being known, you will have the Diameters of all the rest, by taking their respective Numbers from our Table of Proportions, and then working them by the Rule of Three. By what we have been saying, we shall readily come at all the Diameters that are usually found upon the *Calibre Scale*. Moreover we may not only have the Diameters of Globes or Bullets, but also all the Homologous Sides of any Bodies, as well regular as irregular (provided they are made of such Materials as are to be found in our Table) together with their mutual *Ratios* as to Magnitude, as may be conceived by the following Table. As for Example, let there be given a Cube of Wood, whose Weight is 10 Pound, and let it be required of you to make a Cube of Copper of the same Weight with the given one; to do this, divide one Side of the given Cube into a certain number of equal Parts; (but it may not be improper to tell you, that the more Parts you divide it into, the more exact will your Work be;) let us here suppose the Side of the given Cube to be divided into 60 equal Parts; then take their proportional Numbers from the following Table, and range them as usual in cases of the Rule of Three (*viz.*) as 309, the proportional Number of Wood, is to 128, the proportional Number of Copper, so is 60, the Number of Parts into which the Cube of Wood is divided, to the number of the same Parts requisite for the Side of a Cube of Copper, of the same Weight with the Cube of Wood which was given; from which there will arise this Number $24\frac{2}{3}$, which are the Number of Parts of the same Bigness, or Nature with those into which the Cube of Wood was divided, as are necessary for the Side of a Copper Cube, of the same Weight with the Wooden one.

What has now been done with regard to the Side of a Cube, as a regular Body, may be done with respect to the Homologous Sides of an irregular Body; and thus may you have the Magnitudes of *æquiponderant* Bodies, made of different Metals, such as Brass, Iron, &c. and all by the help of Models or Moulds, (to use the term in the *Proplastic Art*) such as the Moulds of all the Pyrotechnical Bodies, which are for

32 *Of the Great Art of ARTILLERY.*

Moreover there are some *Weights* that are used for weighing Gold, Pearl, Coral, and other Things of Value only; and others for Iron, Copper, Lattin, Lead, Tinn, Sulphur, Allum, Wax, Tallow, Hemp, Wool, fresh or salt Meat, Butter, Cheese, and the like Goods of Bulk. Furthermore, there are particular *Weights* used by *Physicians*, *Apothecaries* and *Surgeons*, with which they weigh and adjust the Medicines which they prepare for the humane Body. It is in this Chapter then that I propose to entertain you with the Difference of all these *Weights*; beginning first with those of the *Ancients*, then proceeding to ours, and finishing with those of the most Modern Date, all which we shall enumerate and reduce to an Equality between themselves; which done, we shall show of what Use their Co-equations or Equalities are in *Pyrotechnics*.

As to the *Weights* of the *Ancients*, and the particular Difference between them, the Writings of both *Greek* and *Latin* Authors will fully inform us: We have here collected some of them, of which we shall speak as we go along. In the first place the *Ancients* generally divided their *Weights* into two Classes, (*viz.*) the *Greater* and the *Smaller*; of the *Greater* there was

The *TALENT*, which amongst the *Hebrews* was a kind of *Weight* (without any Mark upon it,) of 3000 *Shekels*, as may plainly be seen in the xxxviiith Chapter of *Exodus*, wherein is mentioned a Sum of 100 *Talents*, and of 1775 *Shekels*, which was collected after 603,550 *Mica* had paid each half a *Shekel*. Now the *Hebrew Talent* contained 100 *Hebrew Mina*, and 120 of *Attica*, or 1500 *Ounces*, 12000 *Drams*, or 125 *Pounds*, each *Pound* weighing 12 *Ounces*. With the *Talent* they weighed Gold, Silver and Copper: See *Villalpandus* upon this Subject in his third Volume, where he powerfully refutes those who differ from him in Opinion. But Authors disagree as to the *Weight* of the *Shekel*. *Mersennus*, in his Treatise of *Measures, Weights and Coins*, assures us, he found that a *Shekel* of Silver (which he would have to be equal in Weight with one of Gold) weighed 268 *Grains*, and from thence concludes, that the *Hebrew Talent* of 3000 *Shekels* was equal to 87 *Pounds* (of 16 *Ounces* each) 3 *Ounces*, 6 *Drams*, and 2 *Denar*, or to 804,000 *Grains*. From whence we see that the *Talent*, as calculated by *Villalpandus*, exceeds that of *Mersennus*, by 6 *Pounds* (of 16 *Ounces* each) 8 *Ounces*, 2 *Drams*, and 2 *Denar*. Some are of Opinion, that the *Hebrews* had two sorts of the *Shekel*, (*viz.*) the common one, or the *Prophane Di-drachma*, and the *Tetra-drachme* of the Sanctuary, which was double the common one. But you may if you please read *Villalpandus* upon this head, where he disputes with great Energy against *Gressius*, and maintains that the *Shekel* was but of one kind, which was of equal Value with the *Athenian Stater*, and not of two, distinguished by the Denominations of *Prophane* and *Sacred*. The *Drachm* which was the fourth part of a *Shekel*, as mentioned in *St. Luke*, Chap. xv. vers^e 8. was equal

Fig N^o 1.

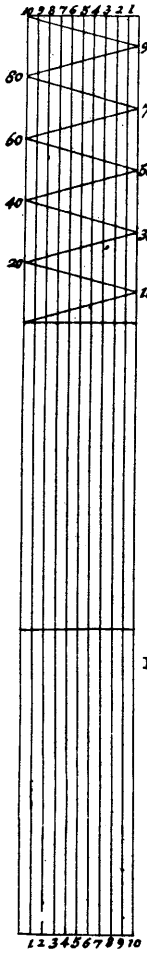

Fig N^o 2.

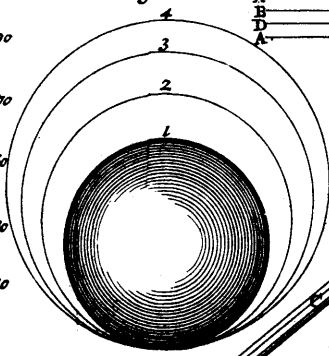

Fig N^o 4.

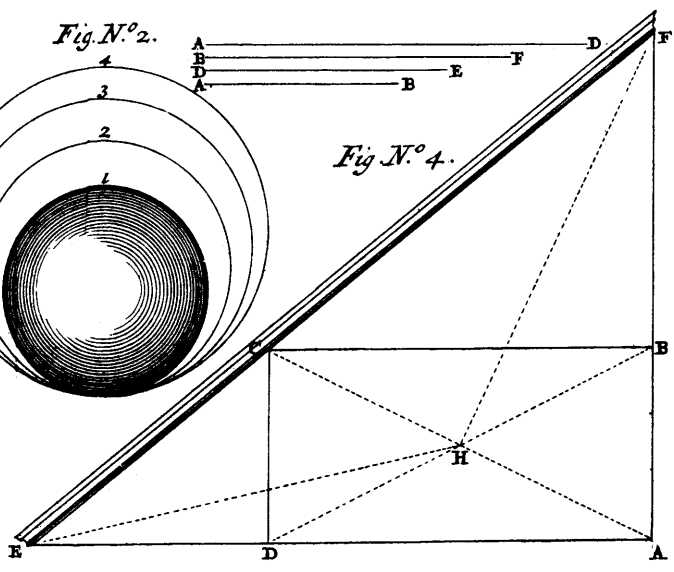

Fig N^o 3.

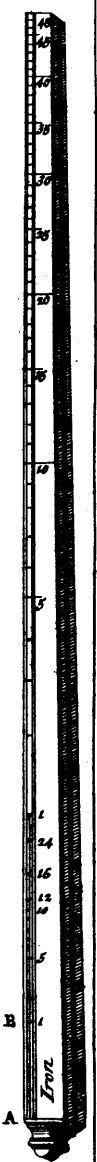

Fig. K N^o 5.

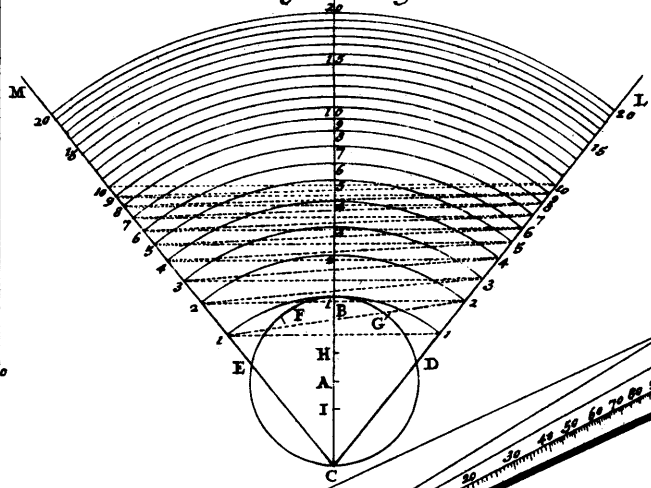

Fig N^o 6.

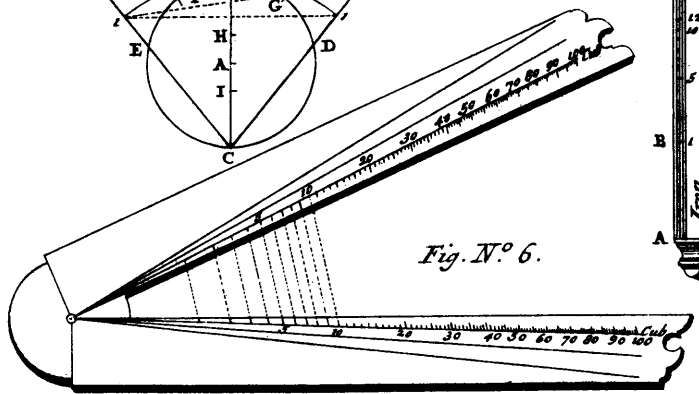
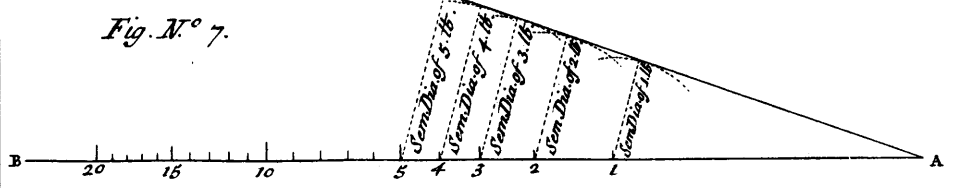

Fig N^o 7.



equal to a *Roman Denarius*; of which in *St. Matth.* Chap. xviii. ver. 22. or as the half, in *St. Matthew*, Chap. xvii. ver. 27. The *Shekel* was composed of 20 *Oboli*, which the *Hebrews* called *Gerab*, and the *Chaldeans*, *Maba*; the *Obolus* according to the common Opinion of the *Rabbins* weighed 16 *Grains* of Barley; from whence (as they equal the *Grains* of an *Ounce*, which we shall speak of hereafter) we may make a *Shekel* or 20 *Oboli* to contain 320 *Grains*. Thus 3000 *Shekels* will weigh 960,000 *Grains*, or 104 Pounds (of 16 *Ounces* each) 2 *Ounces*, 6 *Drams*, and one *Denarius*. But if you would know any thing farther, relating to the Weight of the *Hebrew Shekel*, read *Mersennus of Measures, Weights and Coins*, together with the Authors he quotes upon that Subject.

By Authors we find it for a certainty that the *Talent* amongst the *Romans* was of three sorts. The *Least* of the three weighed 84 Pounds *Roman*. The *Mean* one was 120 Pounds, as *Vitruvius* says in the last Chapter of Book X; where he relates, that *Heliopolis* was so firmly walled with Flints, and so strongly fortified with Hides, that it could bear the Shock of a Stone of 360 Pounds Weight, thrown from the *Balista*; now this was the Weight of three *Talents*, each of which was 120 Pounds. You will find the *Third* and *Greatest Talent*, in *Suidas* and *Hesychius*, who both assert it to have been 125 Pounds, which is a *Weight* equal to an *Hebrew Talent*.

The *Grecian* or *Attic Talent* was 6000 *Drams*, or 60 *Attic Minæ*, as *Suidas* relates from *Pestus*. According to *Villalpandus* it was equal to half of the *Hebrew Talent*; but according to *Suidas* and *Hesychius*, the half of the *Roman Talent*; that is 62½ Pounds *Roman* Weight. The Value of the *Attic Talent* in Money was 600 Crowns; which may give us an Idea of the famous and memorable Liberality of *Alexander the Great* towards Men of Learning, when he presented his Master *Aristotle* with 800 *Talents*, as a Gratification for the Trouble he had been at, in describing to him the Nature of all Animals; which amounted (as some will have it) to 480,000 Crowns: And likewise when he sent Ambassadors to the Philosopher *Xenocrates*, with a Present of 50 *Talents*, which answered to 30,000 Crowns. Besides the *Talents* I have already mentioned there were several others; as

The *Thracian Talent*, which weighed 120 Pounds. The *Ægyptian*, which was 80 Pounds. The *Alexandrian*, which was half of the *Attic Talent* (*viz.*) 31 Pounds, 3 *Ounces*. The *Syrian*, of 1500 *Drams*, or 15 Pounds, 7 *Ounces*, and 4 *Drams*; and that of *Ægina*, which weighed no more than 10 *Drams*.

As to the *Lesser Weights* of the *Ancients*, you will find amongst the *Hebrews*

The *MINA* or *MANEGH*, which was 30 *Shekels* or 120 *Drams*.

The *Grecian Mina* or *Mna* (μνα) was of two sorts (*viz.*) the *Lesser* of 75 *Drams*,

34 Of the Great Art of ARTILLERY.

And the *Greater* (which was bigger than the new one of *Selon*) 100 *Drams*. The *Dram* was divided into 6 *Oboli*; the *Obolus* into 2 *Semi-oboli*; the *Semi-obolus* into 3 *Chalci*; the *Chalcus* into 5 *Leptes*. But for weighing of *Drugs* and *Medicines*, the Physicians and Surgeons divided the *Mina* into 16 *Ounces*; the *Ounce* into 8 *Drams*; the *Dram* into 3 *Scruples*; the *Scruple* into 2 *Oboli*; the *Obolus* into 2 *Semi-oboli*; the *Semi-obolus* into 1 $\frac{1}{2}$ *Siliqua*, and the *Siliqua* into 4 *Grains* or *Moments*.

The *Mina* of *Alexandria* was 20 *Ounces*; and in short to conclude with the *Mina*, the *Ptolemaic* was 8 *Ounces* only.

The *POUND* was what the *Romans* properly called a *Weight*, or *As*, or *Affis*; this *Weight* was the *Least* of the *Greater* Sort or *Class*, and the *Biggest* of the *Lesser*. It was commonly 12 *Ounces*, and this *Roman Pound* was 4 *Drams* lighter than the *Attic Mina*. The *Pound* was originally divided into 12 *Ounces* only; then the *Sextans* was 2 *Ounces*; the *Quadrans* 3 *Ounces*; the *Triens* 4 *Ounces*; the *Quincunx* 5 *Ounces*; the *Semis* 6 *Ounces* (which was also called *half a Pound*;) the *Septunx* was 7 *Ounces*; the *Bessis* 8; the *Dodrans* 9; the *Dextans* 10; and the *Deunx* 11 *Ounces*. The *Pound* was again divided into other smaller *Weights*; as, 24 *half Ounces*; 36 *Duellæ*; 48 *Sicilica*; 72 *Sextula*; into 84 *Denarii*, 168 *Victoriati*, and 288 *Scriptula*.

Besides all this, the *Pound* was a kind of *Measure* amongst the *Romans*, which was divided into 12 *Parts*, which they called *Unciæ* or *Inches*; this they called the *Mensural* or *Measuring Pound*, to distinguish it from the *Ponderal* or *Weighing Pound*. Now this *Mensural Pound*, (according to *Galen* in his *Vth Book of the Composition of Medicaments*) was a kind of *Vessel* made of *Horn*, with which the *Romans* used to measure *Oil*; and was divided by certain *Lines* drawn either withinside or without into 12 *Parts*, which were called *Unciæ*. *Galen* farther informs us in the *VIth Book* of the same *Treatise*, that the whole *Mensural Pound* was equal to but 10 *Ounces* of the *Ponderal Pound*, and consequently was 2 *Ounces* lighter.

We have now spoken sufficiently of the *ancient Weights*; let us proceed to examine the various *Weights* in present Use: amongst which, whether they be of the *Greater* or *Lesser* sort, we shall find a wide difference. But as we have no *Terms* to express them by in our *Language*, no more than we had for those of the *Ancients* which are equally foreign to us; we shall call them by the *Names* they bear in the *Countries* where they are used, and particularly by such *Terms* as are the most common among *Merchants*: And this we shall do with all possible *Brevity*.

DOLIUM (which also is the *Name* of a *Vessel* answering to a *Tunn*) is a *Weight* much used in *Poland* (where it is commonly called *Beczka*) and is 50 *Stones*, or 1600 *Pounds*: I suppose them here to be *Stones* of *Warsaw*, which weigh 32 *Pounds* each.

The **MIGLIER**, which we call the *Millier*, is a *Venetian Weight* of 40 *Miriads* (called in that *Country Miri*) each weighing 25 *Pounds*;

Of the Great Art of ARTILLERY. 35

thus the whole *Millier* will weigh 1000 Pounds, allowing 12 Ounces to each *Pound*.

The BACCAR in the Kingdom of *Calicut*, is a certain *Weight*, that at *Lisbon* answers to 5 great *Quintals*, and weighs in all 640 Pounds.

CALLA, is an *Alexandrian Weight* of 960 Pounds.

CARGO, or CARICO, *Cargoe*, or *Lading*, is a *Weight* commonly used in *France*, *Spain*, *Italy*, and *Portugal*; this is properly the *Load*, or *Burthen* of an *Horfe*, *As*, or *Mule*. In *Spain* it is 3 *Quintals*, which are 360 Pounds, and sometimes 432 Pounds; at *Venice* and *Antwerp* it is 400 Pounds. At *Lions* and every other Place in *France* it is 270 Pounds, and sometimes 300 Pounds. The *Schiffpfundt* of the *Germans* has some Affinity to this sort of *Weight*, as we shall show in its proper Place.

BIRKOWIEC, a *Weight* among the *Muscovites*, and the Inhabitants of *White Russia*, contains 10 other smaller *Weights*, (which the People of those Countries call *Pud*) each of which weighs 36 Pounds, from whence it is that this *Weight* is 360 Pounds in all.

The SCIBA of the *Egyptians* weighs 320 Pounds.

The RIVOLA or *Romula*, a *Weight* used in the Country about *Damascus*, is 225 Pounds.

STAR, amongst the *Venetians*, weighs 360 Pounds, and sometimes 220, 180, 130, or 120, and sometimes but 110 Pounds. This Difference arises from the several sorts of Goods they weigh with it; which I shall not here dwell upon.

The WAGE, a *Weight* amongst the *Belgians*, weighs at *Antwerp* 165 Pounds; at *Bruges* in *Flanders* 30 *Stones*, or 180 Pounds; sometimes at the same Place it is but 20 *Stones* or 120 Pounds; with this they weigh *Butter* and *Cheese*.

QUINTAL, QUINTALO and QUINTALIS; a *Weight* amongst the *Spaniards* and *Portugueze*. In the City of *Leon* it weighs 100 Pounds. At *Seville* the great *Quintal* is 144 Pounds, and contains 4 *Robes*, or *Arrobas* of 42 Pounds each: the little *Quintal* is only 28 Pounds. There also they have another sort of *Quintal* which is 120 Pounds, or 4 *Robes* of 30 Pounds each. The *Portugueze Quintal* is 128 Pounds, and contains in like manner 4 *Robes*, of 32 Pounds each. This is their *Greatest Quintal*: the *Lesser* is but 112 Pounds; which also contains 4 *Robes*, weighing only 28 Pounds each. In the same Country the *Quintal* of *Wax* weighs $1\frac{1}{2}$ of the *Lesser Quintal*, and is therefore 168 Pounds. In the Kingdom of *Fez*, the *Quintal* is 66 Pounds of *Antwerp*, and in *Morocco* and *Guinea* 129 Pounds.

CANTAR and CENTNER is what was anciently called the CENTENARIUS or *Hundred*, which weighed 100 Pounds: from whence it was that in *Nomus* the Soldiers cried out: *Quid fit? Balistas jactas Centenarias*; if it be only that those powerful Machines threw out *Stones* of 100 Pounds? But now this *Weight* is varied prodigiously, and suited to the Convenience of a vast many Nations that make use of it. In

France

36 *Of the Great Art of ARTILLERY.*

France (for Example) in the City of *Paris*, it is divided into 4 *Quartrons*, or *Quarters*, of 25 Pounds each. At *Liens*, *Tbouloufe*, *Avignon*, and *Montpellier* it weighs 112 Pounds. In *Spain* it is 4 *Robas*, each *Roba* 30 Pounds, which added together make 120 Pounds, and answer to the Weight of a *Quintal*. In *Puglia*, *Calabria*, and *Candia*, as also at *Conftantinople*, *Alexandria*, *Aleppo*, and the Islands of *Cyprus* and *Rhodes*, it is 100 *Rotules*; in *Sicily* 61 *Rotules* of 30 Ounces each, make a *Hundred* or *Centenary*. At *Damascus* it contains 5 *Zurls*, or 5 *Stones*, of 20 *Rotules* each. In *Barbary*, it is 5 *Robes*, and every *Robe* 20 *Rotules*; at *Oran* it is 4 *Robes*. In *England* it is 112 Pounds. At *Noremberg* and most of the chief Towns in *Upper Germany* it is 100 Pounds, 120 Pounds, and sometimes 132 Pounds. In *Silefia* and *Vratiflaw* it weighs 5 *Stones* of 24 Pounds each, which is 120 Pounds; the same it weighs at *Hamburg* and *Dantzick*. At *Koningsberg* it is 138 Pounds. At *Lubeck* and *Stetin* in *Pomerania* it is 121 Pounds. At *Cracow* in *Poland* it is 138 Pounds. At *Warsaw* it weighs 5 *Stones* of 32 Pounds each (as I have already said) which make 160 Pounds; in pursuance to the *Orders* established in that Kingdom in the Year 1565. At *Leopole* in *Russia*, it is 5 *Stones* of 30 Pounds each.

The *ROBE* or *Arroba*, is a *Spanish* and *Italian Weight* of 36, 32, 30, and 28 Pounds, as I have already said.

The *STONE*, commonly called *Stein* in the *Upper* and *Lower Germany*, is much used by the *Germans*, *Flemmings*, *Hollanders*, and all the other Nations that inhabit the Borders of the *German Ocean*, and the *Baltick Sea*; as in *Poland*, *Lithuania*, &c. It is likewise used in *Italy*, (*viz.*) at *Rome*, *Florence*, *Bologna*; as well as *Hamburg*, *Lubeck*, and *Stetin*; in all which Places it weighs 10 Pounds: At all these Places they have likewise one of another sort, which is double of the first, and consequently weighs 20 Pounds. At *Vratiflaw* in *Silefia*, it is 24 Pounds; at *Cracow* 25 Pounds; at *Warsaw* and *Lublin* 32 Pounds, in pursuance to the *Orders* issued out by *Sigismundus Augustus* in the Year 1565; at *Leopole* it is 30 Pounds; at *Dantzick* the *Stone* is of two kinds, the *biggest* of which is 34 Pounds, with which they weigh *Flax* and *Wax*; and the *least* is only 24 Pounds, with which they weigh *Drugs*, *Spices*, and all *Aromatick* things. At *Koningsberg* it is also of two sorts, the *biggest* weighing 40 Pounds, and the *least* 25 Pounds. At *Elbing*, *Vilna* in *Lithuania*, at *Riga*, and at *Revel* in *Livonia*, it is 40 Pounds; and at *Thorn* 24 Pounds only.

NAGEL is a *Weight* in *England*, which is particularly used for weighing *Wool*: at *Bruges* in *Flanders* it is 6 Pounds. Furthermore 45 *Nagels* constitute a certain *Weight* which they call *Wage*, 2 *Wages* make a *Sack*, and 3 *Sacks* make a *Seltier* or *Serpelier*. But in *England* the *Nagel* weighs 7 Pounds; 3 *Hundreds* and $\frac{1}{2}$ make a *Sack* of *Wool*, which is 52 *Nagels*; the *TOD* is likewise an *English Weight*, and is 4 *Nagels*.

The

Of the Great Art of ARTILLERY. 37

The ROTULA or SCUTARIA is a *Weight* in *Italy*, and in several Parts of the *East*, as in *Arabia*, *Syria*; *Greece*, *Rhodes*, and *Cyprus*: It is divided into 12 Ounces, *Sacros*, or *Sachosfes*; into 24 *Sexatios* or *Siclos*; into 48 *Denarii*, 7 of which make an Ounce; into 96 *Darquins*, or *Drams*; into 288 *Scruples*; into 576 *Orlossats*, or *Oboli*; into 864 *Danigs*; 1728 *Kirats*, or *Carats*, or *Siliqua*, and into 6912 *Kestufs*, which signify *Grains*. According to *Nicholas Tartaglia*, in his Twelfth Question, the *Rotule* or *Rotula* at *Venice*, weighs 2 Pound, or 33 Ounces and $\frac{1}{3}$, and 3 *Rotules* make 100 Ounces. In *Sicily* the *Rotule* is 30 Ounces; at *Alcairo* it is 6 Pounds; at *Aleppo* 60 Ounces; at the same Place the Ounce is divided into 8 *Metallicks* or *Metecalles* (this is the *Turkish* term for *Drams*) and one *Rotule* is 480 *Metallicks*, each of which weigh $1\frac{1}{3}$ *Peso*, and 10 *Peso* make an *Ongue*, or *Ongy*; in fine, 50 *Metallicks* make a *Turkish Mark*; but 32 of them would constitute ours.

The MINA, MANEG, or MNA, in *Egypt*, weighs 16 Ounces; in *Syria* and *Judea* 18 Ounces; but in some other Places it is found that the *Ancient Grecian Mina* weighed 100 *Drams*.

The POUND, which in *Germany* is called the *Pfundt*, in the *Low-Countries*, *Pond*, and by the *Poles*, *Funt*; is in great request all over *Europe*, and well known to most Nations of the World. But as it is very variously divided by different Nations, and is observed to be very much altered as to Weight, and the Number of smaller Weights it is divided and subdivided into, I shall enlarge a little more than ordinary upon this Subject, and insert here its Differences and unequal Divisions, as practised in the several Provinces and Cities of *Europe*. For this once I shall follow the Order of *Marius Merfennus*, who was a very nice Man in his Observations. I have taken Part of what follows from a Treatise of his, of *Measures, Weights and Coins*. He begins then with the *French Pound*, with which he compares, and to which he reduces the Weight of the Pound in several other Countries. First he divides the *French Pound* into 16 Ounces, the Ounce into 8 *Drams*, the *Dram* into 3 *Scruples*, or *Deniers*; so that the whole *Pound* contains 384 *Scruples* or *Deniers* in all; the *Scruple* is divided into 24 *Grains*, by means of which Division the Ounce will contain 576 *Grains*, and consequently the whole *Pound* is 9216 *Grains*. As to the *Grain*, though it is a very small and inconsiderable Part of the *Pound*, yet he says the *Goldsmiths* in *France* usually subdivide it into 512 *Particles*. He then assures, that he tried and found $\frac{1}{176}$ of a *Grain* weighed at least as much as 40 *Particles* or *Grains* of Sand, from whence it follows, that a *Partiele* of Sand weighs $\frac{1}{176}$ of the *Grain* of an Ounce.

Having thus ascertained the *French Pound*; he teaches a Method by which *Coiners* may make their *Grains* as nice as possible, *viz.* They must first divide the *Pound* into 16 equal Parts, or Ounces; then subdivide each sixteenth Part, or Ounce, again into 24 equal Parts, which will be *Deniers*, and then each *Denier* into 24 other equal Parts, which will be

L

Grains.

38 *Of the Great Art of ARTILLERY.*

Grains. *This last Division may easily be done with a little Plate of Copper or Silver, very thin and longish, that it may be conveniently divided into 24 Particles or little Plates; but Care must be taken that the Plate is equal and uniform throughout all its Dimensions. Some (says he) think it may be done with more Exactness with Brass or Iron Wyre, as being more even and regular than Plates of Copper or Silver; but (to say my Thoughts concerning this Method) if they seek after an extream Quality, by Pieces of Wyre, they take a wrong Method to find it; and the reason is, because the first End of the Wyre that passed through the Hole or Mould, widened it in some Degree or other, and thus that which came through after it will be bigger, and consequently heavier than the first. This Inequality has been sufficiently examined, by the Gold Weights, and discovered by the most exact Scales, and it is impossible to remedy it, whether you file the Wyre or cut off any Part of it, so that you will never this way find out that perfect Geometrical Equality which you sought after.*

Having done with the *French*, he proceeds to the *Roman Pound*, which differs very little in its Division from the first. For it is divided into 12 *Ounces*, the *Ounce* into 8 *Drams*, then into 24 *Deniers*, or into 612 *Grains*. Now the different Weight of the *French* and *Roman Pound*, appears from the Experiments he himself made; for he says that the Difference between the *Roman* and *French Ounce*, is 40 *French Grains*, and that the *Roman Dram* is 67 *French Grains*, and consequently that the *French Dram* is 5 *Grains* heavier than the *Roman*; and that the *Roman Pound* is equal to 11 *Ounces*, 1 *Dram*, and 1 *Denier*: Now if you reduce this into *Grains*, you will find that the *Grains* of the *Roman Pound* will be equal to 6432 *Grains* of the *French Pound*, and consequently that the *French Pound* will be to the *Roman Pound* as 9216, is to 6432.

In the third Place he gives us the *English Pound*, which is what the Goldsmiths particularly make use of to weigh Gold and Silver, and which they commonly call *Troy Weight*. This *Pound* is divided into 12 *Ounces*, each of which is heavier than the *French Ounce*, by 10 *French Grains*. Thus the Proportion of the *French* to the *English Pound* is as 9216 to 7032. The Merchants of this Island have another sort of *Pound*, which they divide into 16 *Ounces*, and which they call *Avoirdupois*; the *Ounce* of this *Pound* is 40 *French Grains* lighter than the *French Ounce*, and consequently equal to a *Roman Ounce*: Thus this whole *Pound* is equivalent to 14 *Ounces*, 7 *Drams*, and 18 *Grains* of *French Weight*. From this we infer that the *French Pound* is to the *English Pound* of *Avoirdupois Weight* as 9216 is to 8586. Now as it happens that the *Ounce* of *Troy Weight*, which being 10 *Grains* heavier than the *French* contains 840 *Grains*; it is plain that the *English Grains* are $\frac{7}{8}$ and half lighter than the *French Grains*. And thus as these *Grains* are of the same Weight in one and the other *English Ounce*, consequent-

ly the *Pound Avoirdupois* of 16 Ounces, will be equal to 14 Ounces and an half *Troy Weight*.

From *England* he goes on to the *Low Countries* or *Holland*, where he assures us he had often made the Experiment, and found, that the *Low Country Half Ounce*, weighs half a *French Grain* more than the *French one*. Thus the *Dutch Pound* of 16 Ounces will weigh 9232 *French Grains*, and consequently the Proportion between the *French* and the *Dutch Pound* will be as 9216 is to 9232. In the *Low Countries* they divide the *Ounce* into 20 *Anglics*, (which the *Dutch* call *Engelschen*) and the *Anglic* is subdivided into 32 *Grains*. Thus the *Dutch Ounce* will weigh 640 *Dutch Grains*, and from thence it will follow that the *Dutch Grains* are about $\frac{1}{7}$ lighter than the *French ones*.

As to the *Spanish Pound*, he does not pretend to know any thing of that by his own Experience; and only says, that he has heard that it is equal to 15 Ounces, and 24 *Grains* of *French Weight*. But I find by *Villalpandus*, that the *Pound* is of three Sorts among the *Spaniards* (*viz.*) the Bigger of 32 Ounces; the Mean of 16; and the Lesser (which they call *Argentaria*) of 8 Ounces.

I shall here subjoin the Divisions and Subdivisions of the *Pound*, in several other particular Provinces and Cities, from my own Experience, or from the Information I have had from others.

In *Poland* the *Royal Pound* is 32 *Loths* or *Half Ounces*; each *Loth* weighing $1\frac{1}{4}$ *Sicilica*, which in the Language of the Country are called *Skoycie*; therefore the whole *Pound* weighs 48 *Sicilica*. The *Dantzic Pound* is in like manner divided into 32 *Loths*, and the *Loth* into 4 *Quarters*, which they also call *Quintleyn*; the *Quarter* into 4 *Sesheres* or *Ponderal Nommules*. Consequently the *Dantzic Pound* is composed of 512 *Nommules*. Now since it happens that 32 of these *Nommules* make an *Ounce* of a *Pound*, it will necessarily follow, that 4 *Nommules* will make a *Drachm*, and thus a *Nommule* will weigh 18 *Grains*; from whence it will follow, that the whole *Pound* will be composed of 9216 *Grains*, which are equal in Number to the *Grains* that constitute the *French Pound*, as we have before observed from *Mersennus*. Now in order to know what Proportion a *Grain* of the *Dantzic Pound*, may bear to the *Grain* of a *French Pound*; please to take notice of what follows. *Peter Crugerus*, one of the most famous Mathematicians in *Dantzic*, assures us (in a little Treatise of *Arithmetic* which he wrote in *Germany*;) he had often experienced that the half *Pound* of *Cracow* (which the *Poles* call *Grzywna*, and the *Germans* *March*) weighed 16 *Loths*, and 12 *Nommules* of *Dantzic*; that is, that the half *Pound* of *Cracow* is 12 *Nommules* heavier than the half *Pound* of *Dantzic* of 16 *Loths*. From whence we may conclude, that the *Dantzic Pound* is so that of *Cracow*, as 9216 is to 9648. But inasmuch as it is the most current Opinion, amongst *Goldsmiths*, as well as the most received one amongst the generality of the *Poles*, that the *Cracowian* half *Pound* ought to weigh 7

Impe-

40 *Of the Great Art of ARTILLERY.*

Imperial Dollars, or *Silver Crowns*, and inasmuch as the aforementioned *Peter Crugerus* says he himself tryed and found that 7 *Dutch Dollars* weighed 16 *Loths*, and 12 or 13 *Dantzic Nommules*, and that upon a second Tryal, he found that 7 new *Saxon Dollars* weighed 17 *Loths* and one or two *Nommules* of *Dantzic*; it will follow that 7 *Dollars* want but little of being equal to the *Cracovian half Pound*; which agrees very well with the common Opinion with regard to this matter; which on the other hand agrees with the Observations of *Crugerus*, who having taken upon him to examine the Weight of the *Cracovian* and *Dantzic half Pound*, we shall particularly stick to what he says; that we may avoid the Confusion and Trouble, which a Diversity of Observations might introduce into our Discourse.

But since *Merfennus* in his *Treatise of Measures*, &c. makes the *Imperial Dollar* and that of *Burgundy* or *Flanders* (which the *French* call *Patagons*; and which are very well known all over the *Low Countries*) to weigh 22 *Deniers*, or 528 *French Grains*, it will follow, that the *Cracovian Pound*, weighing 14 of the like *Dollars*, will be equal to 7392 *French Grains*; and the *Pound* of *Dantzic* to 7061 of the like *Grains*. The *Warsovia* *Pound* is an *Ounce* lighter than the *Dantzic Pound*, as I myself have experimented, it weighing but 8640 *Dantzic Grains*; therefore the *Warsovia* bears such Proportion to the *Cracovian Pound*, as 8640 does to 9648; that is, it is lighter by 1008 *Grains*, which are equal to one *Ounce*, 5 *Drams*, 2 *Deniers*, and 21 *Grains*. But it weighs 6619 $\frac{2}{3}$ *French Grains*. The *Pound* of *Koningsberg* bears such Proportion to that of *Dantzic* as 8121 $\frac{1}{3}$ does to 9216, as appears by *Peter Crugerus*, who found that 160 *Pounds* of *Koningsberg*, were equal to 141 *Pounds* of *Dantzic*. The *Pound* of *Vilna* is equal to 29 and $\frac{1}{11}$ *Loths* of *Dantzic*, and weighs 8378 $\frac{1}{11}$ of *Dantzic Grains*. The *Pound* of *Noremberg* is equal to 11511 *Dantzic Grains*; therefore it exceeds the *Dantzic Pound* by 2295 *Dantzic Grains*; which are equal to 7 *Loths*, 3 *Drams*, 2 *Deniers* and 5 *Grains*. That of *Cologne* weighs 39 *Loths* and 3 *Nommules*, or 11286 *Dantzic Grains*; therefore it exceeds the *Dantzic Pound* by 2070 *Grains*, or 7 *Loths*, 2 *Deniers*, and 6 *Grains* of *Dantzic Weight*. In pursuance of an *Imperial Mandate*, the half *Pound* of *Cologne* ought to weigh 8 *Imperial Dollars*, which *Crugerus* says he found to be the Weight of it; the whole *Pound* therefore must weigh 16 *Dollars*, and consequently it will bear such Proportion to the *Cracovian Pound*, as 8 does to 7; or that it must be $\frac{1}{7}$ or 2 *Ounces* heavier than that of *Cracow*. *Crugerus* moreover observed that the *Dutch half Pound* (which is called *Troy-gewicht*, and *Troyische Marck* by the *Germans*) weighs 20 *Loths* and 10 *Nommules*, or 5940 *Dantzic Grains*; therefore the whole *Dutch Pound* is equal to 11880 of the same *Grains*, and exceeds the *Dantzic Pound* by 2664 *Grains*, or 9 *Loths* and one *Dram*; whereas it exceeds the *Cracovian* but by 2232 *Dantzic Grains*, or 7 *Loths*, 2 *Drams*, and 3 *Nommules*. From whence we may conclude, that

that the *Ounce* of this *Dutch Troy Pound*, as commonly divided into 20 *Anglics*, or into 640 *Grains* (which some mean by the Word *Asen*) contains 742 $\frac{1}{2}$ of *Dantzic Grains*; and consequently that the *Dantzic Grains* are lighter than those of *Holland*. The same *Dutch Ounce*, (according to *Willebrordus Snellius*, in his *Eratoſthenes Botanic*. Lib. II. Cap. V.) weighs 9 *Golden Roſe-Crowns*, commonly called *Roſen-Nobel* or *Roſe-Nobles*, which *Crugerus* having tried, found that 4 of thoſe *Nobles* or *Crowns*, weighed 2 *Loths*, 9 *Nommules* and $\frac{1}{2}$ of *Dantzic*, or 742 $\frac{1}{2}$ *Grains*. The ſame Author in the ſame place will have it, that this *Ounce* is equal to the *old Roman Ounce*. Again, if we compare this *Batavian Pound* with that of *France*, we ſhall find that it weighs near 9104 *French Grains*. From whence it is evident, that the above Obſervations of *Merſennus*, concerning the *Dutch* or *Batavian Pound*, differ from this laſt; inasmuch as *Merſennus* has made the *Dutch Pound* to weigh 9232 *French Grains*, whiſt *Crugerus* allows it to be equal to no more than 9104 of the ſame *Grains*; ſo that there is a Difference of 128 *Grains* between them. The *Pound of Elbing* is exactly equal to that of *Dantzic*. But let us now proceed to the Diviſions and Subdiviſions of the *Pound*, as they are variously practiſed in ſeveral other Provinces and Cities. As for Example; at *Rome*, *Florence*, and *Bologna*, they have a certain *Pound* of 30 *Ounces*; with which they commonly weigh Wax and Wool. At *Milan*, *Pavia*, and *Cremona*, the *Pound* with which they weigh Fleſh, is 28 *Ounces*. At *Venice* the *Pound* is divided into 12 *Ounces*, 72 *Sextules*, 1720 *Silics*, and 6912 *Grains*. At *Vienna* in *Austria*; the *Pound* is divided into 32 *Loths*, 128 *Quints*, 512 *Deniers*, and 12800 *Grains*. At *Antwerp* the *Pound* is of 16 *Ounces*. At *Bruges* in *Flanders* of 14 *Ounces*; but at the ſame Place they have another ſort of *Pound*, which is divided into 16 *Ounces*; therefore the 100 *Pounds* of 16 *Ounces* each, are equal to 108 *Pounds* of 14 *Ounces* each: At the ſame Place they ſubdivide the *Ounce* into 2 *Loths*, the *Loth* into 4 *Sifanits*, the *Sifanit* into 2 *Drams* or *Quints*. In the Kingdom of *Fex*, the *Pound* is of 18 *Ounces*.

In ſhort the *Medicinal Pound*, which is properly the *Old Roman Pound*, is divided into 12 *Ounces*, into 24 *half Ounces*, into 69 *Drams*, into 288 *Scruples*, into 576 *Obols*, into 1728 *Silica*, and into 5760 *Grains*.

I ſhall here ſubjoin the Characters uſed by *Physicians*, *Apothecaries* and *Surgeons*, to expreſs all the *Parts* of a *Pound*: for Example; the *Pound* is expreſſed thus lb̄, an *Ounce* ℥ j; two *Ounces* ℥ ij, and ſo on till you come to half a *Pound*, which is thus expreſſed lb̄s; a *Dram* ℥ j; two *Drams* ℥ ij; and ſo on to Eight. The *Scruple* thus ℥; and the *Grain* thus gr. Pleaſe to obſerve that we ſhall make uſe of theſe Characters for the future, to avoid the too frequent Repetition of the Words.

There are 9 *Veſſels* of Metal, made like *Cups*, that answer to the Weight of one *Pound*. The firſt with all the reſt in it weighs one *Pound*, or 16 *Ounces*, and by itſelf 8 *Ounces*. The Second with thoſe contained

42 *Of the Great Art of ARTILLERY.*

in it weighs 8 Ounces or half a Pound, and by it self 4 Ounces. The third with those contained in it 4 Ounces, and by itself 2 Ounces. The Fourth with *Sc.* 2 Ounces, and by itself 1 Ounce. The Fifth *Sc.* 1 Ounce, and by itself 4 Drams. The Sixth *Sc.* 4 Drams, and by itself 2 Drams. The Seventh *Sc.* 2 Drams, and by itself 1 Dram. The Eighth *Sc.* 1 Dram, and by itself 1 $\frac{1}{2}$ Scruple. And the last 1 $\frac{1}{2}$ Scruple or 36 Grains.

Observe here that we have said, in the former Part of this Chapter, that the *Hebrew Shekel*, according to *Merfennus*, weighed 268 French Grains; but since *Merfennus*, in Lib. IX. of his *Treatise of Measures, Weights and Coins*, will absolutely have it, that the *Imperial Dollar* answers nearly to 2 *Shekels*, inasmuch as 2 *Shekels* are equal to 536 French Grains; it must follow that 28 *Shekels* are equal to 14 *Imperial Dollars*, each *Dollar* weighing 536 French Grains; which being compared with the *Cracovian Pound*, it will infallibly be found to weigh 7504 French Grains. Again, the *Low-Country Pound* (whose Proportion to the *Cracovian Pound* we have already considered) will be found to weigh 9104 of the same Grains; which Number, as it does not differ very much from the Observations of *Merfennus*, as to the Proportion that this *Pound* bears to that of *France*, seems to me to be the most reasonable, and therefore I choose to stick by this Proportion; for I am of Opinion, that *Merfennus* has assigned a Weight to the *Imperial Dollar* which would have agreed better with the *Flemmish Patagon*; this latter being in some degree different from the former, whether as to Purity of Silver, Value and Weight, it being commonly lighter. But I shall leave this to the Decision of those who are perfectly skilled in what relates to Money and Coins.

The MARK of Money, which the *Latins* called *Marcha* and *Libra*, *Nummularia*, or *Nummaria*, and which we shall call with them the *Nummular Mark* or *Pound*, is much used by Moneyers, Goldsmiths, and all those who are concerned in the Manufacture of Gold and Silver. In *Poland*, that of *Cracow* is 8 Ounces, or 16 *Loths*, which are equal to 17 *Loths*, 7 *Nommules*, and $\frac{1}{2}$ of *Dantzic*. That of *Dantzic* weighs also 16 *Loths*, or 256 *Nommules*, or 1024 *Quarters*. The proportion of this to the above-mentioned half *Pound* of *Dantzic* is as 4054 is to 4608; that is, that the latter exceeds the former by 554 Grains, which are exactly 1 *Loth*, 14 *Nommules*, and 14 Grains. The *Dantzic Mark* is particularly used in weighing Silver, and is divided into 24 *Sicilies*, each of which is subdivided into 4 *Quarters*; but that with which they weigh Gold, Pearl, and all sorts of Jewels, is divided into 24 *Carats*, each of which weighs 12 Grains, or 4 *Quarters*. The *Mark* of *Elbing*, is the same with that of *Dantzic*. That of *Antwerp* weighs 8 Ounces, or 160 *Anglics*, or 5120 Grains; there likewise the *Anglic* is subdivided into 6 *Carats*; thus 960 *Carats* constitute a *Mark* of *Antwerp*; 200 of which *Marks* are *Equiponderant* with 105 common Pounds

Of the Great Art of ARTILLERY. 43

Pounds of the same Place. The *Dutch Mark* is 8 *Ounces*, the *Ounce* 24 *Nommules*, and the *Nommule* 24 *Grains*. The *Roman Mark* is 8 *Ounces*, the *Ounce* 8 *Drams*, the *Dram* 3 *Scruples*, the *Scruple* 2 *Oboli*, the *Obolus* 3 *Silics*, and the *Silic* 4 *Grains*. The *French Mark*, according to *Mersennus*, is 8 *Ounces*; but we have already said enough of its Subdivisions. The *Venetian Mark* is likewise divided into 8 *Ounces*, into 32 *Quarters*, into 1152 *Carats*, or *Silics*; and into 4608 *Grains*. The *Nummular* or *Money Pound of Florence* is divided into 24 half *Ounces*, or *Loths*, into 288 *Nommules*, and into 6912 *Grains*. The *Golden Mark of Genoa* is 8 *Ounces*, or 192 *Nommules*, or 4608 *Grains*. At the same place the *Silver Pound* is divided into 12 *Ounces*, 288 *Nommules*, and 6912 *Grains*. The *Money Pound of Naples* is 12 *Ounces*, or 96 *Octaves*. In *Portugal* it is 8 *Ounces*, or 64 *Octaves*, or 288 *Grains*. In *Misnia* and *Saxony* it is 8 *Ounces*, or 192 *Nommules*, or 4608 *Grains*. And to conclude, that of *Nuremburg* is 16 *Loths*, or 64 *Quarters*, or 256 *Primes* or *Nommules*, or 1024 *Sixteenths*.

We have I think said enough of the different Properties and Proportions of *Weights*, as well *Ancient* as *Modern*; and I believe that no body will, after reading this, meet with any Difficulty or Doubt, concerning their Co-equations and *Ratios* to one another. I would only observe to you, that if you are desirous of being farther satisfied upon this Head, you may have recourse to a small *Flemmish Book*, publish'd by an Anonymous Author at *Amsterdam*, in the Year 1647, entitled *Treſſor van de Gewichten, Maten van Korn ende Landen, &c.* from whence I borrowed a great many curious things, which are inserted in this Chapter. After having reduced almost all the *Weights* in the Universe, and compared them with the *Ancient Roman Standard*, and to one another, I have with the utmost Care calculated a *Table* in a circular Form, the Use of which I shall illustrate by the following Proposition.

Let there be given (for Example) a piece of Ordnance made in *Italy*, that carries a Ball or Bullet of 60 lb *Roman*; to know how many *Pounds of Amsterdam* it would weigh; you may proceed in the following manner. (*viz.*) as 100 lb *Roman*, are to 76 lb of *Amsterdam*, in the given *Table*, so is 60 lb *Roman*, which is the Weight of the given Bullet, to the Weight of it in *Amsterdam Pounds*, which was required. This being performed after the common way, you will have 45 $\frac{1}{2}$ lb, which will be the Weight sought of the given Bullet. This will hold good in all the like Cases, and it will be impossible for you to err, if you follow the Rules we have laid down.

I shall here, by way of *Corollary*, subjoin some Remarks taken from *Mersennus's Book of Measures &c.* to prevent our being no more perplexed by the Defect, and great and frequent Imperfection of *Weights*, than by the great Difference and Variety between them; but that on
the

44 *Of the Great Art of ARTILLERY.*

the contrary, when we meet with any thing of this kind that cannot possibly be rectified by our utmost Industry and Application, it may be given over and rejected, in consideration of that great Degree of Incertitude, that inseparably accompanies almost every human Action.

Having carefully sought after the Cause of all these Differences and Defects, which could no ways be attributed to the Balance, nor to the various Tenour of the Air, no more than to the breathing of those who lifted up or held the Balance, which may seem to have a troublesome Effect, and to disturb the Equilibrium; I at length found out, that all this Diversity proceeded from the Standard Weights, which are kept in Town Halls and Mints, for the Examination of all other Weights; inasmuch as these three Models or Standard Weights, of which the biggest is 64 Marks, the mean 32, and the least 16, or 32, 16, and 8 Pound, do not so exactly correspond with each other, but that there is a Difference between them of several Grains; by which means the Ounce of one is not exactly the Ounce of the other: But that we may not rashly accuse the Wardens, who have the keeping of these Weights, nor the Workman who made them, of either Negligence or Dishonesty: I must here say, that it is a very hard Matter, or that in short it is impossible that these Weights, let them have been made in what Manner, or of what Material soever, nay if their Consistence had been as durable as Adamant, to preserve their original Size in its utmost Extent, or that nice Proportion with which they were at first endued.

Let there be (for Example) two Brass Weights of one Pound each, adjusted to each other with all the Nicety that the Industry of Man is capable of, yet this nice Equality cannot always, (nor indeed for any considerable time,) remain in that extreme Degree of Perfection as you may imagine; and the reason of it is, because, as these Weights are from time to time handled, in the daily Examination of other Weights, they wear out or waste a little by that Means, so that the more they are handled or moved about, the lighter they will become: from whence it happened that the famous Examiner of Weights, Semillardus, discovered his Mark, or half Pound, to have lost 3 Grains of its Weight in 2 Years time; which consequently would have diminished it 300 Grains in 200 Years, and in short an entire Ounce or 576 Grains in the Space of 432 Years.

But you may say, in answer to this; that these two Standard Weights should be equally handled, as often as there is occasion to make use of them, to the end that the one may be lessened in an exact Proportion with the other; but to this I reply (not to mention the Difficulty of managing so, as that both shall be agitated with an equal Motion, and handled so nicely alike, that a Person might say he had equally lessened them) who is he that can boast of knowing perfectly how much his first handling wore them, how much it wore them in a Year, or indeed in an Age? Let us therefore conclude, that we can be sure of nothing upon this Head, no more than in several other Cases wherewith we in vain perplex ourselves. Let us be well satisfied, if there should be a Grain or two of Difference between two

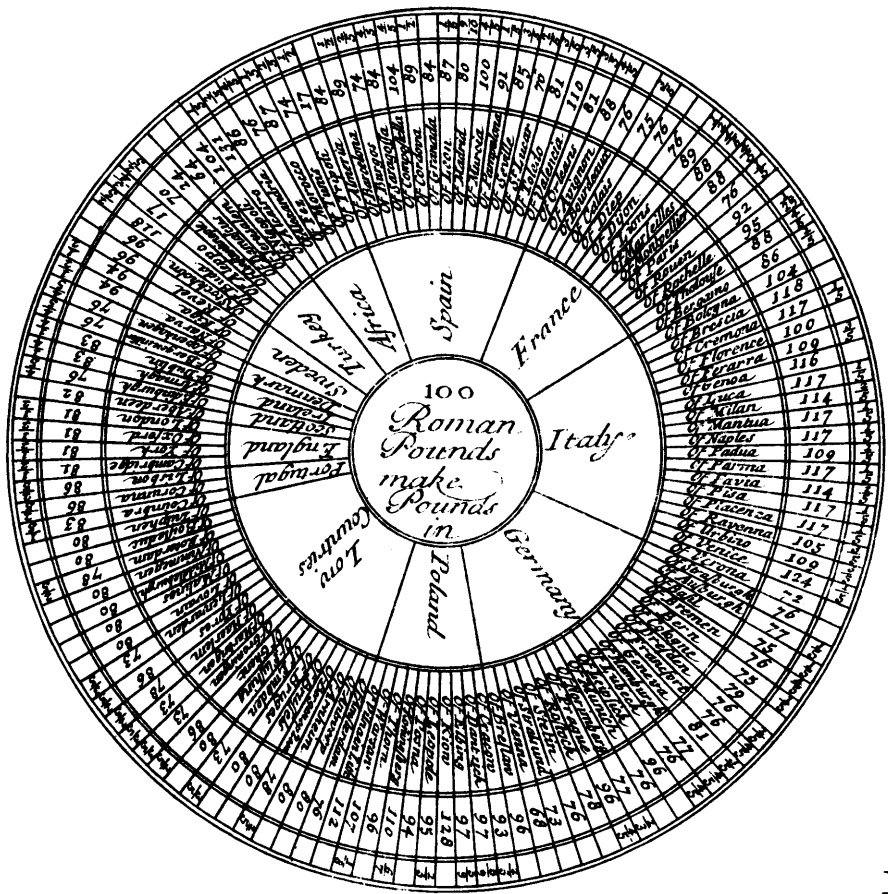
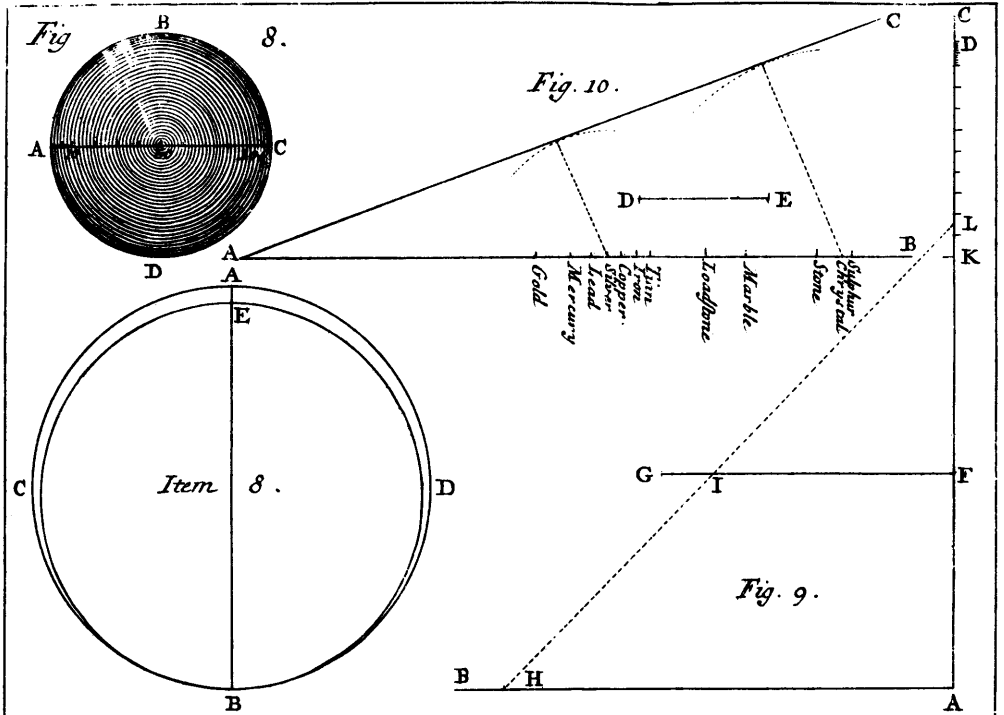

Weights; which is such a Trifle, that it cannot well be said to be injurious either to the People or the State; for to what purpose should we seek after that Geometrical Perfection, which is not only incompatible with all Human and Mechanical Things; but also, absolutely inconsistent with the Weakness of our Nature?

CH A P. XI.

Of Weighing INSTRUMENTS.

WE usually examine all manner of *Weights*, with two sorts of *Instruments*, viz. the *Balance*, or *Scales*, and the *Steel-yard*, which some call the *Statera Romana*. We shall here set forth in the most concise Manner we are able, the Origin of both the one and the other of them; their Properties, their Use, their particular Forms and Figures, and in short the manner of their Construction.

Of the BALANCE.

Some will have it that the *Balance*, and *Steel-yard* derive their Origin and fundamental Principles, from these two general *Axioms* in *Mechanicks* (viz.) that *Equal Weights weigh equally at equal Distances, but unequally, at unequal Distances*: and this other, that *unequal Weights weigh unequally at equal Distances, but that they weigh equally at unequal Distances, provided that their Distances are in a reciprocal Proportion to their Weights*. Those who would be satisfied as to these Demonstrations, may find them in *Guido Ubaldo*, *Galileus*, *Simon Stevin*, *John Buteo*, in *Guevara*, and several other Mechanical Writers, who have enlarged very much upon this Subject. As for me, though I know that this Matter has been very learnedly treated of by a great many, I yet think they have left me some little to say; or at least I may have leave to entertain such as are Lovers of the *Mathematicks*, with an Abridgement of what so many others have discoursed of so largely, and demonstrated with so much Prolixity. I shall then endeavour to render my Essay useful by means of one Figure, which I shall here give you.

Suppose, for Example, that the Right Line A, B. in Fig. 11, be the *Brachia* or Beam of the *Balance*, and that G is the *Axis* or Center. Now let us suppose that A and B are *equidistant* from G, and the *Weights* suspended at those two Points will infallibly *equiponderate*, if they are equal to one another; it being very evident from our general *Postulata*, that two Bodies of the same Weight, and at equal Distances from their common Center, are in *Equilibrio*, in the Point of their common Conjunction, and in the Termination of their equal Distances. Thus the

N

Bodies

46 *Of the Great Art of ARTILLERY.*

Bodies E and F, being supposed of equal Weight, and the Right Line A and B, by the Extremities of which they are suspended, being divided in such a Manner, that A, G, and B, G, are equal, and A and B *æquidistant* from the Center, it will necessarily follow that the Point of *Æquilibrium* of both Bodies is in G, which it would not be if they did not weigh equally, or if they had been suspended at unequal Distances; neither of which happens in the present Case. But you must observe here, that the *Weights* must hang by Lines that are perfectly perpendicular. For suppose the Body E be suspended at the Point K, and that the Right Line G, K, be equal to the Right Line A, G, or G, B, and that the Line of Direction K, I, by which the Body E, tends towards the Center of the Earth, intersects the Right Line A, B, in I; now because G, I, is not equal to A, G, or G, B, the Body E will no longer *æquiponderate* with F suspended at B; by which it must plainly appear, that for Bodies to be in *Æquilibrium*, it is not only necessary that they be of equal Weight, but likewise that they be *æquidistant* from the Center of the *Balance*. I shall now show you the *Figure* of it, and furnish you with some useful Observations concerning the nice Construction and Examination of it.

In *Fig. 12.* you have the Form of the Beam or *Brachia* of the *Balance*; whereby Smiths, Scale-makers, &c. may see how to adjust them. The right Line A, B, is the fundamental Line of the whole *Machine*, which is exactly divided in the middle by the Right Line C, D, in the Point E; to this are joined two others that are parallel to it, and *æquidistant* from E (*viz.*) F, G, and H, I, divided in the like manner by C, D, in K, and L; from L describe with the Line L, M, the Circle M, N, W, P, divide the inferior Semi-diameter of this Circle into 4 equal Parts, at the Points L, O, and R, and from thence you may easily know the Distances of the Parallels G, F, and H, I, from the Line A, B, (*viz.*) the eighth Part of the Diameter M, W, or the fourth Part of the Semi-diameter L, M. From the Point K, the Center of the *Balance*, describe a Circle with the prick Line K, a, or E, K, which is included in the Square, b, c, d, e, and where Workmen commonly put a kind of Nail or *Axis* which is round at Top, a little angular at the Bottom, and pointed at the End, upon which the whole *Machine* turns; now the Diameter of this *Axis* ought to be very little less than the Semi-diameter of the Circle included within the Square. This *Axis* is fixed in an Handle, (the *Figure* of which you may see under the Letter B,) which sustains the whole Burthen of the *Balance* and *Weights*. The *Brachia* A, E, and E, B, are measured from E, and terminate always in the Lines M, W, or P, N, six, eight or more times measured from E towards A or B. Observe here, that the longer the *Brachia* are, the nicer will the *Balance* be. They make the *Fulcrum* of the Beam after this manner, (*viz.*) Describe a Circle from L with the prick Line L, D, or L, C, (which is equal to $\frac{1}{4}$ of the Semi-diameter L, M,) then divide the Peri-

Periphery of it into 6 equal Parts in the Points C, S, h, D, g, V, then through the Points g, V, and h, S, produce the right Lines g, T, and h, Q, till they join the right Line T, Q, drawn parallel to the right Line A, B, through the Point C: Now if from T, and Q, you describe the Segments V, f, and Z, S, the upper part of the Beam will be formed. Then from P, and N, set the Distance between P, U, and N, S, towards X and Y; and from I and H, draw the right Lines Y, I, and H, X, towards Y and X, and you will have the thickness of the *Brachia*. Moreover from the Points X, D, and D, Y, between X, D, and D, Y, let there be the equilateral Triangles, X, D, i, and D, Y, k. In short, having described the two Segments X, D, and D, Y, from the Points k and i, you will have the lower part of the Beam formed. The *Trutina*, or *Cock C, M*, must be as long as one of the *Brachia*. The Heads or Buttons of the *Brachia A, B*, are made by certain small Circles described round A and B, with the prickt Line of a quarter of the Semi-diameter M, O; the small *Axes* at the Heads of the *Brachia*, or Points of Suspension from which the Scales commonly hang, are made in the same Form as the great *Axis* in the Center of the *Balance*. We may easily determine their Proportion by making small Squares under A and B, between the parallel Lines A, B, and H, I, the Intersection of whose Diagonals will give their Centers, from whence small Circles may be described in their just Proportion to the *Axis* of the *Balance*, in the Form of which they must be wrought.

The *Scales* must be of equal Weight; and if the Ropes or Chains (by one of which great *Scales* are always suspended) are of the Length of the whole Beam they will be the more exact. This is what I had to say with regard to the Construction of the *Balance*, which is sufficient for this time. I shall now subjoin some Observations which I have taken from good Authors, which may be of use to you in judging of the Perfection or Imperfection of any *Balance* whatsoever.

OBSERVATION I.

The longer the *Balance* is the more exact will it be, inasmuch as it's *Brachia* describe a larger Circle than the *Brachia* of small ones; from whence also in large *Balances* their Velocity is encreased, they being less attracted by the Center to a circular Motion, which is unnatural to them; and, on the contrary, less hindered from a rectilinear or perpendicular Motion, which is natural to them, and by which the Extremities of the *Brachia* would descend, if not confined and carried round by the Center of the *Balance*; therefore the longer the *Brachia* are, the more free and unconstrained will their Motion be; thus the greater the Circumferences they describe, the nearer will their Motion approach to a right Line: If to this you object, that great *Scales* are not near so nice and exact as the smaller which are used by Lapidaries and Goldsmiths; that

48 *Of the Great Art of ARTILLERY.*

is entirely owing to the coarse and stubborn Materials, of which large *Balances* are commonly made, whereas the smaller are curiously wrought and polished. To conclude; the *Ratio* of their Velocities is as the Diameters of the Circumferences or Circles they describe; and the longer the *Brachia* of a *Balance* are, by so much will they be more sensibly acted upon, by the *Weights* suspended from them, and will descend with the greater Velocity.

OBSERVATION II.

Scales when without *Weights* may be in *Æquilibrio*, though at the same time they may be subject to *Deceit*. For if the *Axis* or Center of Motion is not exactly in the middle of the *Beam*, and the *Scale* that hangs by the shortest *Brachium* is made of knotty Wood, or has had melted Lead poured any where into it, the *Balance* may be in perfect *Æquilibrio*. Let the shortest *Brachium*, for Example; be divided into 10 Parts, and the longest into 15, and let the *Scale* suspended by the *Latter* weigh 10, and that suspended by the *Former* weigh 15; and their *Weights* and *Distances* being by this Means in a reciprocal Proportion, they will be in *Æquilibrio*; and so they will continue to be if you put in the *Scale* of the shortest *Brachium* a Weight of 6 Ounces, (for Example) and in the other a Weight that is to 6 as 10 is to 15; upon this Account it was, that *Aristotle* (in his Book of *Mech. Quest. I.*) rebuked so sharply those Dealers in Purple; for 4 being to 6 as 10 is to 15; they certainly sold 4 Ounces of Silk for 6, which was very unjust. But you will easily discover the *Deceit* by reciprocally shifting the *Weights* from one *Scale* to the other.

OBSERVATION III.

It is not sufficient to allow for the Length of either of the *Brachia* by adding a greater or lesser *Weight* to either Side; for it is better not to admit or trust to this Method of making amends for the different Lengths of the *Brachia*, though it might in some sort be allowed: But be assured that the nearer the *Brachia* are to an Equality between themselves, the more certain and useful the *Balance* will be: And if ever you are obliged to make use of such that are not so very perfect, you cannot be too cautious in preventing Errors and Mistakes.

OBSERVATION IV.

The *Plane* upon which the *Scales* of the *Balance* are at rest, or in *Æquilibrio*, ought to be perfectly Horizontal, and exactly upon a *Level*; for if the *Scales* do not rest upon one and the same *Plane*, but that on the contrary one of them is depressed and the other elevated, they will

not in that Case be in *Æquilibrio*; notwithstanding they might be so when they were both upon the same Horizontal Plane; but that which is depressed will overbalance that which is elevated, nor will the *Balance* readily restore itself to an Horizontal Position; because the Pressure which compelled one of the *Scales* to descend, remains impressed a considerable time after it is down; let therefore your *Scales* be gently brought to the same Plane, that you may find whether or no they will be in *Æquilibrio*.

Of the STATERA ROMANA commonly called the
STEEL-YARD.

Although what I have said of the *Balance*, might be sufficient to illustrate the Nature, and Properties of this *Machine*; yet as it differs in its Construction from the *Balance*, I shall, (to prevent the Confusion and Perplexity that might arise from their different Form) subjoin something particularly relating to it. Let us look back to Fig. 11. where the right Line A, G, C, represents the Beam or *Brachia* of the Steel-yard, whose longest *Brachium* is G, C, and its shortest A, G; G being the *Axis* or Center of Motion. Let the Proportion between A, G, and G, C, be as 1 to 10; now if the *Weight* suspended at A weighs 10 lb, and that suspended at C, weighs but one lb, they will be in *Æquilibrio*. For according to what was laid down in the last of the two Mechanical *Axioms*; (*viz.*) that unequal *Weights* will equiponderate when suspended at *Distances* that are in a reciprocal Proportion to their *Weights*; it must follow, that as A, G, is but a tenth part of the *Brachium* G, C, and the *Weight* suspended at C being but a tenth part of the *Weight* suspended at A, that their *Weights* and *Distances* being thus in a reciprocal Proportion to one another they will equiponderate. Some will have it that this *Æquilibrium* is produced by the smaller *Weight*; having ten times more Motion and Velocity, as it describes a Circle ten times greater than the larger *Weight*; for, as we have said elsewhere, the farther a Point is removed from its Center, the greater Circle will it describe; so that if any *Weight* be situated at 10 Feet from the Center of Motion, it describes a Circle ten times greater, and goes through ten times the Space, that a *Weight* which is but one Foot from the Center does in the same time; thus the *Velocity* of the smaller is equal to the *Gravity* of the larger *Weight*.

We have said enough of the Properties of the *Steel-yard*, let us now proceed to consider the Construction of it, as it is represented Figures 13. We must first then look upon the Right Line A, B, C, as the Fundamental Line of the whole *Machine*: The Distance between A and B, being the shortest *Brachium*, and that between B and C, the longest; you may suppose the Proportions of them to be in what *Ratio* you please; but in this Case the *Brachia* are to one another as 1 to 5. The *Fulcrum* of the *Steel-yard* may be constructed after this manner: Let the Distance between A and B be divided into 5 equal Parts; from B, the Center of the

50 *Of the Great Art of ARTILLERY.*

Steel-yard raise the perpendicular B, D, upon the Right Line A, C; and upon the Line B, D, set off towards D, $\frac{1}{2}$ of the Distance between A and B; let the Perpendicular B, D, be continued downwards as far as E, to the length of $\frac{1}{2}$ of the Distance between A and B, so that the whole Line D, E, may be equal to the Distance between A and B. From the Point E, upon E, D, extend a Perpendicular on the Right and Left to the Points G and F, each of them equal to $\frac{1}{2}$ of the same Distance, and compleat the two Squares E, F, H, Q, and E, G, I, Q: From G and F, with the prickt Lines G, E, and F, E, describe the Segments or Arches H, E, and E, I; this done, the lower Part of the Instrument will be formed. Now to construct the upper Part, let the two Perpendiculars D, M, and D, N, be produced to D, E, equal to $\frac{1}{2}$ of the Distance between A and B; let them be continued to L and K to the Length of $\frac{1}{2}$ minus $\frac{1}{2}$ of the aforementioned Distance. Then from L and K describe the Arches P, N, and M, O, with the prickt Lines K, N, and L, M; and thus you will have the upper Part of the *Steel-yard* constructed. As for the Head or Button, it cannot be wrought after a better or more convenient Fashion than what I have drawn in the *Figure*, (*viz.*) If in the Circle S, U, T, X, Z, whose Diameter going through the Center is $\frac{1}{2}$ of the Distance between A and B you make small Mouldings or Roundings S, Z, S, U, U T, T a a: The *Axes* R and Y are the Height of $\frac{1}{2}$ of the aforesaid distance, and are made with an Edge that nearly touches the Right Line A, C; you will have the thicknes of the longest *Brachium* if from C to ff you take $\frac{1}{2}$ of the same distance I have so often mentioned, and if from ff and C you draw the Right Line, ff, I, and C, P; in short, the Right Line s, c c, being produced through the middle between them, it will give this *Brachium* the Resemblance of a *Rhomboides* in its *Orthographical Figure*. In short, you must take the *Axis* or Handle D, d d, equal to treble the Line A, B; and as for the three Ornaments that are commonly upon the *Brachia* and *Axis* of this Instrument, they must be referred to the Fancy or Discretion of the Workman; but for such as are not Artists, the *Scenographical Figures* I have drawn, may sufficiently instruct them. I have nothing more to say upon this Head, except it be to shew you a way of dividing the longest *Brachium*, which is done by equal Parts, calculated for the Examination or Determination of the smallest *Weights* that are used. I have said above that in our Example the shortest *Brachium* A, B, was to the longest *Brachium* B, C, as 1 to 5; therefore upon the *Brachium* B, C, you must distinguish the Distances or Parts with small Lines or suitable Numbers, beginning to reckon the Distances from the Center of Motion B, and going on towards C; all these Parts or Distances may be subdivided into any Number of smaller Parts, that shall be deemed proper or necessary. The *Counter* or *Running Weight* which hangs by a *Ring*, and slides along the *Brachium*, weighs sometimes one lb, sometimes 10 lb and 100, or more or less according to the size of the *Steel-yard*, the use

use of which must appear evident to you from what I have been saying, and all the Observations that can be made upon it are founded upon the reciprocal Proportion of *Weights*, and their *Distances* from the Center. But since *John Butco*, and others have spoken largely upon this Head, I shall conclude this Chapter with some Observations that are in some sort necessary, for the right conceiving the Nature and Use of this *Machine*.

OBSERVATION I.

You must reckon the *Distances* upon the *Steel-yard* from that Point where it hangs and moves round freely, and the Points by which the *Weights* on either Side are suspended.

OBSERVATION II.

Several *Weights* hanging at several *Distances* on the longest *Bracchium* of the *Steel-yard*, may *æquiperate* with a single *Weight* suspended from the shortest. To do this it is required, that the Product of that *Weight*, multiplied by its *Distance* from the Center, be equal to the Sum of the Products of all the other *Weights*, each being multiplied by its *Distance* from the Center.

OBSERVATION III.

That it is upon the same *Principles* with the *Steel-yard*, that the deceitful *Balance* is founded; which cheats by the Inequality of the *Brachia*.

OBSERVATION IV.

Of two *Weights* which seem to be, and are in reality in *Æquilibrio*, the *heaviest* bears always such Proportion to the *lightest*, as the longest *Bracchium* does to the shortest. From whence you may observe that the *lightest Weights* seem to weigh as much as the *heaviest*, which they do in appearance only, by means of their reciprocal *Distances* from the Center. Hence you may perceive, that for Bodies to be of equal *Weight*, and to *æquiperate*, or be in *Æquilibrio*, are different Things. From which it follows, that if a Body twice as *light*, is at twice the *Distance* from the Center as a Body twice as *heavy*; or that if a Body a thousand times *lighter*, is a thousand times more *distant* from the Center than a Body a thousand times *heavier*, they will be in *Æquilibrio*.

C H A P. XII.

The Ancient and Modern Liquid and Dry Measures carefully reduc'd to the Weights.

THE Collection that we have made of all the *Weights* which are used in almost all the *Districts* of the *World*, and which we have treated of in the *Tenth Chapter* of this *Book*, with the utmost *Exactness* and *Brevity* the *Subject* would admit of; leads us now to consider the *Liquid* and *Dry Measures* in *Ancient* and *Present Use*, and to reduce them to the *Weights*; conceiving that it will be a *Work* not wholly *unuseful* to the *Pyrotechnician*, or others who voluntarily apply themselves to the *Study* of the *Mechanicks*: But here both *Reason*, and the order of *Things*, require us to associate and compare the *Measures* with the *Weights*, because we frequently confound them together, and indifferently make use of both, without distinguishing between their different kinds. But before we enter upon this we must premise the following *Observation*,
(viz.)

That both *Liquid* and *Dry* things vary infinitely with regard to *Weight*; which does not only arise from the *Diversity* of their *Species*, but we find it also in one and the same *Specie*; so that *Water* does not only differ in *Weight* from *Wine*, from *Oil*, from *Milk*, from *Beer*, from *Brandy*, and from other *Liquids*; but we find also that there is an *Inequality* of *Weight* between *Water* and *Water*, *Wine* and *Wine*, &c. Again, we find that *Wheat* is heavier than *Wheat*, *Rye* heavier than *Rye*, *Oats* than *Oats*, *Barley* than *Barley*, and so on. Since then *Things* of one and the same *Specie* agree so little within themselves, it can be no *Difficulty* to conceive, that they will greatly differ in *Weight* from one another, though with regard to *Measure* they may be equal, which you must always suppose. I must therefore desire you would keep in mind, what I have already said of the mutual *Ratios* of *Metals*, *Minerals*, &c. And since it is impossible to ascertain the particular and exact *Proportion* of any *Liquid* or *Dry Things* to others of different *Species*, I shall here only subjoin some general *Observations*, and *Experiments* that have been made, to clear up this *Intricacy*: And First,

That *Sea Water* is naturally heavier than any kind of *Fresh Water*: That of the different sorts of *Fresh Water*, *Rain Water* is the lightest. Moreover that there is a great *Inequality* of *Weight* between *River*, *Spring*, *Well*, *Pond*, *Rain*, *Snow*, and *Ice Water*, and all sorts of *Water* whether *Hot* or *Cold*.

Again, *Water* weighs heavier at one *Season* than at another. Furthermore, *Water* will weigh in a certain *Proportion* near the *Place* from whence it issues out, and in a different *Proportion* after it has run some distance

distance from it; and if you observe the *Weight of Water* before it is frozen, you will infallibly find it varied after it is thawed; to illustrate this; Experience evinces, that *Ice* is lighter than *Water*, by the former's swimming on the Surface of the latter.

I shall designedly pass over several sorts of *Water* of different Colours, Tastes, and Odours; nor will I take notice of such kinds of it as are Glutinous, Bituminous, Aluminous, Sulphureous, or Salt; nor dwell upon those that inebriate and disturb the Brains of Persons who drink of it. I shall likewise be silent with regard to several Oily Springs, one of which *Pliny* describes in his xxxi. Book, Chap. 11. near *Soli* a City in *Cilicia*; *Theophrastus* relates a Spring of the same sort to be in *Ethiopia*; *Solinus* speaks of another in his Chap. xxiii; and *Philander* makes mention of another in his *Remarks* on Chap. iii, Book the viii, of *Vitruvius*; but these I shall pass over, as well as several others, whether the Accounts given of them be true or false, the latter of which they commonly are. I find nothing of this kind worthy our Observation, except what *Cassiodorus* says Book iv. on the Variety, in the Letter sent by *Theodoric* first King of the *Ostrogoths* to the Earl *Apronian*, (viz.) *That Waters issuing out towards the East and South, are clear, sweet, and very wholesome, by reason of their lightness; but that on the contrary those that flow towards the West and North, are too cold, gross and unwholesome.* *Solinus* relates something of this kind, in speaking of the River *Himera* (viz.) *That this River varied its Taste as it changed its Climate, being bitter as it flowed towards the North, and sweet when it bent its Course towards the South.* And doubtless the Diversity of Soils through which *Water* flows may not only have an Effect upon the Taste of it, but upon the Weight of it likewise, by making it lighter or heavier than when it first issued out of its Source. But to speak one Word in general of Oily Springs, we may conclude they are much lighter than any others. If you are desirous of being perfectly informed of the Nature of Springs and Waters, consult *Aristotle*, *Seneca*, *Pliny*, *Cato*, *Varro*, (where he treats of Country Affairs) *Averroes*, *Palladius*, *Columella*, *Vitruvius*, *Frontinus*, *Boccace*, and many others, who will fully satisfy you upon this Head. I only thought myself obliged to say thus much, to show the infinite Variety as to *Weight*, between Things of one and the same kind in particular, and between one another in general.

All sorts of *Wine* are lighter than *Water*, but as they differ very much from one another they weigh differently; for so far are the *Wines* of *Falernia*, *Crete*, *Spain*, *France*, *Italy*, *Hungary*, *Turkey*, *Wallachia*, and several others from agreeing with one another in *Weight*; that on the contrary *Cretan Wine* differs from *Cretan*, and *Falernian* from *Falernian*; and these in general are lighter or heavier than the others we have mentioned. They likewise weigh variously at different Seasons of the Year; in short, the newer any *Wine* is the heavier it will be, and the older it is, the lighter.

54 *Of the Great Art of ARTILLERY.*

Oils are lighter than either *Water* or *Wine*, as appears by their Property of swimming on the Surface of those two Liquids, though never so much incorporated and mixed with them: but the different Specifick Gravities of *Oil* and *Oil* are still more remarkable, for *Oil of Olives, Almonds, Wallnuts, Linseed, Turnips*, and all that are made by a Press or any Engine of that nature, are much heavier than *Oils* extracted by *Alembicks, Stills, Matraffes*, and such like Chymical Vessels that are more artificial.

In short, all distilled *Waters, Spirits* and *Essences*, prepared after the same manner with *Oils*, weigh less than such *Oils*, let them be what they will; and these likewise differ very much in *Weight* from one another. I shall not here enumerate an infinite Number of other *Liquids*, whose Specifick Gravities you may at your Leisure examine. This Research I shall leave to those, who have more Time to devote to their Curiosity; as for me, I have but little enough left, to treat on Subjects which are much more useful and necessary.

All sorts of *Grain* (as I have already said) vary infinitely with regard to *Weight* when of one and the same *Kind*, and from one another when of different *Species*; so that it is difficult to ascertain any thing, as to the mutual *Ratio* they bear to one another. However, I shall insert what I have discovered by Experiments. I say then, that *Wheat* is heavier than *Rye*, *Rye* than *Barley*, and *Barley* than *Oats*; though their several Grains frequently vary as to *Size* and *Weight*. Now many Causes may be assigned for this Variety, whereof the Richness and Fertility of Soil is none of the least; for it is highly probable that fat Ground contributes greatly to a fine Crop; because of its natural Moisture, which is better able to nourish its Fruit, than a dry hungry Piece of Ground, that has not wherewithal to cherish what it was naturally scarce able to bring forth.

The Second Cause to which it may be attributed, is the various Climates and Regions, and the different Situation of Fields and Grounds in the several parts of the Earth: as *Virgil* has it *Georg. lib. 1.*

*Hic segetes, illic veniunt felicius uvaë:
Arboris fetus alibi, atque injussa virescunt
Gramina.*

In *English* thus,

This ground with *Bacchus*, that with *Ceres* fruits:
The other loads the Trees with happy Fruits.
A fourth with Grass unbidden decks the Ground.

Dryden.

And truly this matter deserves our Consideration, inasmuch as we are assur'd by Merchants, who are the most experienced in this Branch

Of the Great Art of ARTILLERY. 55

Branch of Trade, that the *Amsterdam Mude* of Polish *Wheat*, or of any of its circumadjacent Provinces, weighs 150 lb; that the same *Measure* of French *Wheat* weighs 180 lb; of *Sardinian*, 220 lb; of *Sicilian*, 224 lb; of *Beotian*, 230 lb; and of *African Wheat*, 236 lb; Hear now what *Vitruvius* says upon this Subject, Lib. VIII. and Cap. III.

The Variety of the Fruits of the Earth, such as the Canes and Reeds of Syria and Arabia, and the several sorts of Odoriferous Herbs, and Aromatic Trees, &c. all of so different a Nature; is owing to the Variety of Climates and Regions. This Diversity of Climates does not only influence the Vegetable World, but affects likewise the Animal World in as various a manner; and proceeds from the Inclination, or Parallelism of the Earth, and the Consequents of its Oblique Situation, (viz.) the different Degrees or Portions of Heat distributed to the several Regions of the Earth, which are by that means endued with particular Properties.

Again; the difference between Grain is owing to the Variety of Seasons; for continual Rains, and thick close Weather, will naturally make Corn poor and light; it being in such a case impossible for it to arrive at compleat Maturity, for want of that genial Warmth, which is necessary to effect it.

It has not been without some secret Mystery, that the Husbandman has carefully observed the proper times for Sowing his Ground; he knows what Seed to sow when the Moon is in the Encrease; what in her Wane; what to sow when her Horns are sharp-pointed; and what, when she shines out with her full and borrowed Lustre. They are well acquainted with the different Situations of the Heavenly Bodies; their Rising and Setting; and with every thing else, that may prove hurtful to the Harvest, and ruin their Hopes, at the very Instant they commit them to the Bosom of all-bearing Mother Earth. *Virgil* very elegantly warns them upon this head in the Book I before quoted.

*Ante tibi Eoæ Atlantides abscondantur,
Gnoshaque ardentis decedat stella Coronæ;
Debita quam fulcis committas Semina, quamque
Invita properes anni spem credere terra.
Multi ante occasum Maiaæ cœpere: sed illos
Expectata seges vanis elusit aristis.*

In English thus,

But if your Care to Wheat alone extend,
Let *Maja* with her Sisters first descend,
And the bright *Gnosian* Diadem downward bend;

56 *Of the Great Art of ARTILLERY.*

Before you trust in Earth your future Hope;
 Or else expect a listless, lazy Crop.
 Some Swains have sown before, but most have found
 A husky Harvest from the grudging Ground.

Dryden.

From all this we may conclude, that it is impossible to ascertain exactly the different Specifick Gravity of *Grain* and *Seed*. I could say much more to prove the Incertitude of this Matter, but shall forbear speaking any farther concerning it. I shall only here insert the Testimony of *Merjennus*, to confirm the Truth of what I have here said. Speaking of this Subject in the Preface of his Book of *Measures, Weights, &c.* he tells us, " That having weigh'd all the Sorts of *Grain* " and *Seed* usually sold in *Paris*, he could hardly find two Grains of " same *Specie*, that exactly answered to one another, which rendering " his Attempt uncertain, he gave it over; and that besides their being " naturally different from one another in *Size* and *Weight*, they are sub- " ject to such Alterations by accidental Moisture and Dryness, and by " the Evaporation of their finer Particles, that it is impossible to ascer- " tain the Specifick Gravities of *Grain* or *Seeds*; and that this Incer- " titude extends in some degree to all natural Bodies.

Secondly, In order to reduce *Liquid Measures* to the *Weights* which are in present use, we will, in the Sequel of our Discourse, suppose, that the *Roman Mensural Pound* was equal to 10 *Unciæ* of the *Ponderal Pound*, or that they were to one another as 10 to 12; the *Ponderal Pound*, (as we have already said) containing 12 *Unciæ* or *Ounces*, and each *Ounce* 612 *Roman Grains*, and consequently the whole *Pound* must be 7344 *Grains*. By reducing this *Pound* to the other of 16 *Ounces* (as has been done by several modern *Pyrotechnicians*) we mean that the *Ounce* of this, or $\frac{10}{16}$ of it, should contain 576 *Grains*; but these *Grains* will not be of equal *Weight* with the *Roman Grains*, theirs being lighter than ours; so that 612 *Grains* of the *Roman Ounce* are equal to but 536 *Grains* of our *Ounce*; and thus our *Pound* weighing 9216 *Grains*, is heavier than the *Roman Pound* by 2784 of its own *Grains*; consequently the *Roman Ponderal Pound* weigh'd 6432 of our *Grains*, which we have said from *Merjennus* in his Co-equation of the *French* and *Roman Pound*. As to the modern *Roman Grains*, we here suppose them to be equal to the *Ancient* (though we are not assur'd of that) and we have likewise reduced the *Ounce* of our *Pound* to an Equality with the *French Ounce*, because its *Grains* agree nearly with the *Weight* of pick'd *Barley-corns*; according to the old Example and Practice of the *Greeks* and *Romans*, as well as of the *Hebrews*, who first made use of them.

Thirdly, When in speaking of the *Measures*, we shall say that such a *Measure* weighs so many *Pounds* or *Ounces*; whether they belong to the Country where the *Measure* is used, or to any City or Country in *Eu-*

rope

rope that may be mentioned, those *Pounds* or *Ounces* may be easily reduced to what *Weights* you will; provided you have recourse to the Method observed in the general *Circular Table*, the Use of which I have already taught you; or if you keep in Mind the mutual Proportions of *Weights*, which we have amply displayed in the Tenth Chapter of this Book.

The Liquid and Dry Measures of the Ancient Romans.

DOLIUM was a kind of Jar, or Earthen Vessel, which the *Ancients* sunk into the Ground to keep Wine; it contained 1 $\frac{1}{2}$ *Culeus*, that is, 2400 lb *Mensural*, and 2000 lb *Ponderal* of Rome; but of our *Weight* 1395 lb, 13 *Oun.* 2 *Dr.* and 2 *Den.*

CULEUS was a Leathern Vessel, which held 20 *Ampora* of Liquids, which is 1600 lb *Mensural*, (witness *Fannius* and *Columella*.) and 1333 lb, 4 *Oun.* of Roman *Weight*; and of ours 930 lb, 1 *Oun.* 1 *Dr.* and 8 *Gr.*

MEDIMNUS was a *Dry Measure*, which held 6 *Modii* or 2 *Ampora*; that is, 160 lb *Mensural*, or 133 lb, and 4 *Oun.* Roman *Weight*, and 93 lb, 7 *Dr.* and 8 *Grains* of our *Weight*. It held 144 lb of Wheat, Roman *Measure*; and *Columella* tells us, they had another *Dry Measure* amongst them, which held 10 *Modii*, from whence it was called **DECIMODIUM**.

They had moreover a third *Dry Measure*, more capacious than the two former, which they called **TRIMEDIMNUM**, because it held three *Medimni*, or 18 *Modii*, or 6 *Ampora*, or 480 lb *Mensural*, or 400 lb *Ponderal* of Rome, or 279 lb, 2 *Oun.* 5 *Dr.* and 1 *Den.* of our *Weight*.

HYDRIA was a great Pitcher to carry Water, and held 1 $\frac{1}{2}$ *Ampora*, according to *Villaspandus* upon *Genesis*; that is, 120 lb *Mensural*, or 100 lb *Ponderal*, or 69 lb, 12 *Oun.* 5 *Dr.* 1 *Den.* of our *Weight*.

CADUS of the same Dimensions with the *Hydria*, according to the Testimony of *Fannius*, and held 108 lb. of Wheat. This (he says) was the true *Dry Measure*.

AMPHORA, or **QUADRANTAL**, (witness *Cato*, *Fannius*, *Columella*, *Volutius*, *Metianus*, and several others) held 2 *Urnae*, and weigh'd 80 lb *Mensural*, or 66 lb, 8 *Oun.* *Ponderal*; or 46 lb, 6 *Oun.* 3 *Dr.* 1 *Den.* and 16 *Gr.* of our *Weight*. This was a *Dry Measure* amongst the *Romans*, and held 72 lb of Wheat. *Mersennus*, in his Reduction of this *Measure* to the *Parisian Pound*, says, that 72 lb Roman, are equal to 50 lb, 4 *Oun.* *Parisian*, by which he means that the Roman *Quadrantal* held so many *Pounds* and *Ounces* of Wheat. This would be very true if these 72 lb Roman were *Ponderal*; but as Authors conclude them to be *Mensural*, therefore as 72 lb *Mensural* are equal but to 60 lb *Ponderal*, it can be equal to but 41 lb, 14 *Ounces* of *Paris*; which

58 *Of the Great Art of ARTILLERY.*

we designing to make use of in this Chapter, you must take particular Notice of it in the Sequel of our Co-equations. Perhaps (which I do not remember to have read) the *Romans* had two sorts of the *Pound* to weigh and measure *Liquids* only, and another for the use of *Dry things* only (*viz.*) the *Ponderal Pound*. The Vessel of a *Roman Cubic Foot*, which is said to have held 80 lb *Mensural* of Water, was equal to the *Ampbora*. *Dioscorides* however will have it, that the *Ampbora* held but 52 lb of Vinegar and 80 lb of Wine. *Galen*, on the contrary, says, that the *Ampbora* held 72 lb of Oil, 80 lb of Wine, and 108 lb of Honey. *Merfennus* assures us, that he found (upon making the Experiment) that the *Roman Cubic Foot*, such as the *Congialis* of *Villalpandus*, weighed 74 lb of *Paris Weight*; but there are those who differ from him upon this Article.

The same Author lays it down for a certainty, and will have it (by the Observations of *Gassendus*) that the *Roman Ampbora* held 55 lb and 14 *Oun.* of Water of *Parisian Weight*; since the *Congius*, which is $\frac{1}{4}$ of the *Ampbora*, holds (according to him) 7 lb minus $\frac{1}{4}$ of an *Ounce* of Water; from whence we may plainly discover that these 80 lb *Roman*, which formerly filled the *Roman Ampbora*, were of the *Ponderal* kind. But we shall leave this to the Discussion of those who have more time to spare than we have, and shall now proceed with our *Measures* in the Order we began.

The *URNA* or *URN* was (according to *Cato*) a *Liquid Measure* of half the Capacity of the *Ampbora*; but it was sometimes used to measure *Dry things*, and, according to what *Villalpandus* says, it held $1\frac{1}{2}$ *Modius*, or 4 *Congii*, or 40 lb *Mensural*, or 33 lb, 4 *Oun.* *Ponderal*, and of our *Weight* 23 lb, 3 *Oun.* 1 *Dr.* 2 *Den.* and 8 *Gr.*

The *MINA* was equal to the *Urna*.

The *MODUS*, if we may believe *Fannius*, was properly a *Dry Measure*, of $\frac{1}{2}$ of the *Medimnus*, and $\frac{1}{4}$ of the *Ampbora*; this held exactly 24 lb *Roman* of Wheat. Now as to *Liquids*, (here we are chiefly to suppose Wine and Water, which agree the nearest in *Weight*) it is certain that the *Romans* used but one *Measure* for them, which (as we have already said) they called the *Mensural Pound*; as a *Liquid Measure*, it held 26 lb, 8 *Oun.* *Mensural*, or 22 lb, 2 *Oun.* 5 *Dr.* 1 *Den.* and $\frac{1}{2}$ *Gr.* *Ponderal*, and of our *Weight* 15 lb, 7 *Oun.* 3 *Dr.* 2 *Den.* and 13 *Gr.*

The *CONGIUS*, which was $\frac{1}{4}$ of the *Ampbora*, held 6 *Sextarii*, or 10 lb *Mensural*, or 8 lb, 4 *Oun.* *Ponderal*, and of our *Weight* 5 lb, 12 *Oun.* 6 *Dr.* 1 *Den.* and 8 *Gr.*

The *SEXTARIUS* held 2 *Hemina*, or 1 lb *Mensural*, and 2 *Bessis* of 8 *Ounces*, which made 20 in all; or 1 lb, 4 *Oun.* 5 *Dr.* and 1 *Den.* *Ponderal*; and of our *Weight* 15 *Oun.* 3 *Dr.* 2 *Den.* and $5\frac{1}{2}$ *Gr.* The *Romans* had another *Sextarius*, which was called *Sextarius Rusticus*, and was double of this.

Of the Great Art of ARTILLERY. 59

The HEMINA, which was also called COTYLA, was a certain Measure which held 2 *Quartarii*, or 10 *Oun. Mensural*, or 8 *Oun. 2 Dr. 2 Den.* and $\frac{1}{2}$ *Gr. Ponderal*, and of our Weight 7 *Oun. 5 Dr. 2 Den.* and $14 \frac{1}{2}$ *Gr.*

The QUARTARIUS held 2 *Acetabula*, or 5 *Oun. Mensural*, or 4 *Oun. 1 Dr. 1 Den.* and $\frac{1}{2}$ *Gr. Ponderal*, or 3 *Oun. 6 Dr. 2 Den.* and 19 *Gr.* of our Weight.

The ACETABULUM was a kind of small Cup or Sawcer, and held $1 \frac{1}{2}$ *Cyathus*, or 2 *Oun. 4 Dr. Mensural*, or 2 *Oun. 2 Den.* and $\frac{1}{2}$ *Gr. Ponderal*, and of our Weight 1 *Oun. 7 Dr. 1 Den.* and $9 \frac{1}{2}$ *Gr.*

CYATHUS was a small Measure in the form of the *Acetabulum*, and held 4 *Coclearii* or Spoonfuls; that is, 1 *Oun. 5 Dr. and 1 Den. Mensural*, or 1 *Oun. 3 Dr. and 8 Gr. Ponderal*, or 1 *Oun. 2 Dr. and 23 \frac{1}{2} Gr.* of our Weight.

COCLEARIUM or SPOON was the $\frac{1}{4}$ of the *Cyathus*, and was equal to 3 *Dr. and 1 Den. Mensural*, or 2 *Dr. 2 Den. and 8 \frac{1}{2} Gr. Ponderal*, and in short 2 *Dr. 1 Den. and 17 \frac{1}{2} Gr.* of our Weight.

Liquid and Dry Measures of the Antient Grecians.

The METRETA or METRETES of Attica held 3 Roman Urns; therefore it was equal to the Roman Pitcher or Cadus.

The ATRABA was $3 \frac{1}{2}$ Roman Medii, according to Cato and Columella.

The LACONICK METRETA was a little less than the Roman Amphora.

The ATTICK AMPHORA was equal to the Metreta, accord to Fannius and Villalpandus.

The AMPHOREUS was but half of the Metreta, according to Agricola and Villalpandus.

The CHUS or CHOAS was equal to the Roman Congius.

The COTYLA, which was also called TRIBLIUM, was equal to the Roman Hemina.

The OXYBAPHUM was equal to the Roman Acetabulum.

The MYSTRUM was of two sorts, the greater being $\frac{1}{16}$ of the Cotyla, and the lesser but $\frac{1}{24}$ of the same.

The CHEME or CHEMA was equal to the Roman Coclearium, or Spoon.

Observe here that it will be very easy to reduce these Measures to the ancient Mensural and Ponderal Pounds, as well as to ours; they being indifferently used formerly, in measuring or weighing both Liquid and Dry Goods.

Liquid and Dry Measures of the Ancient Hebrews.

CHORUS, CHONER, or HOMER (as we have it in our *English Translation*) held 2 *Letbecs*; it was equal to $\frac{1}{2}$ of the *Roman Culeus*, or 45 *Modii*; this was indifferently used in measuring both *Liquid* and *Dry Things*. I shall not give myself the trouble of reducing these *Measures* to the *Weights*; for any body may do it as well as I, who does but apprehend what has already been said. This *Measure* is mentioned in the Prophet *Ezekiel*, and in the 3d Book of *Kings*, Chap. v. Ver. 2. and the 2d Book of *Chronicles*, Chap. xxvii. Ver. 5. and in *St. Luke*, Chap. xvi. Ver. 7. Some are of Opinion that this was the Load of a Camel.

LETHEC, the $\frac{1}{2}$ of the *Chorus*, held 5 *Baths* or *Ephas*, which were equal to 15 *Roman Urns*, or 22 $\frac{1}{2}$ *Modii*.

The BATH or EPHA was $\frac{1}{2}$ of the *Letbec*, and held 3 *Seab*, or 10 *Omers*; this *Measure* was equal to the *Roman Hydria* or *Cadus*, and to the *Attick Metreta*. *Josephus* mentions this *Measure* in his *History of the Jews*; and *Villalpandus* also speaks somewhere of it.

SEAH or SATUM, the $\frac{1}{2}$ of the *Epha* or *Bath*, was two *Hin*; it was equal to 1 $\frac{1}{2}$ *Modius*, or 24 *Sextarii* of *Roman Measure*, according to *Villalpandus*. But *Alcanzar* will have it to have been equal to the *Modius*, by which he doubtless means the *Attick Modius*, that being $\frac{1}{2}$ of the *Roman*. This *Measure* is mentioned in *Genesis* xviii. Ver. 6. and in *St. Matthew* v. Ver. 15.

HIN was the $\frac{1}{4}$ of the *Seab*, and held 3 *Cabs*; it was equal to 12 *Sextarii* or 2 *Congii* of *Rome*; it is spoken of in *Exodus* xxix. Ver. 40. and in *Ezekiel* iv. Ver. 11.

OMER, $\frac{1}{4}$ of the *Epha*, was equal to 7 $\frac{1}{2}$ *Roman Sextarii*; something is said of it in *Exodus* xvi. Ver. 37.

CAB, the $\frac{1}{3}$ of the *Hin*, was 4 *Logs*, and was exactly equal to 4 *Sextarii*; we find this *Measure* spoken of in the 2d Book of *Kings*, Chap. vi. Ver. 25.

The LOG, $\frac{1}{3}$ of the *Cab*, held 6 *Egg-shells*, and was equal to a *Roman Sextarius*. Some say that the *Thebans* had a *Measure* equal to this, and that it was the same which *Epiphanius* calls *Aporrhyma*.

The EGG-SHELL, $\frac{1}{6}$ of the *Log*, and $\frac{1}{12}$ of the *Epha*, is thought to have held 2 *Oun.* 6 *Dr.* and 1 *Den.*

We have said enough of the *Ancient Measures*; proceed we now to those which are more *Modern*, and consequently more familiar to us.

But I must premise that I do not here undertake a detail of the *Measures*, used throughout all the Kingdoms and States of the Earth. That would be an Attempt as vain as it is impossible. Therefore I shall only remark such as are current in the most famous and best known Cities and Provinces in the World. I shall be obliged to call them by the

Names

Of the Great Art of ARTILLERY. 61

Names they bear in their respective Countries; and to conclude, I shall reduce them to the *Weights*, as I have already done with regard to those of the *Ancients*.

Spanish Liquid Measure.

The BOTA or BUTT holds 30 *Robas*, each *Roba* weighing 30 lb, it answers to 160 *Antwerp Stopes*; but the *Roba* is only 5 *Stopes* $\frac{1}{2}$. The *Antwerp Stope* weighs 6 lb, and consequently the BUTT weighs 960 lb of *Antwerp*.

The PIPA or PIPE weighs 30 *Robas* of 28 lb each.

The ROBA is 8 *Sommers*.

The SOMMER is 4 *Quartillas*, each of which weighs $\frac{1}{4}$ of the *Antwerp Stope*, and consequently weighs 1 lb.

The *Spaniards* have another kind of *Pipe*, of different Capacity from the abovementioned, with which they commonly measure *Oil of Olives*, it contains 40 *Robas*; but those *Robas* are lighter than the others, as we have already said.

Dry Measure of the same Nation.

The CAHI holds 12 *Hennegas* or *Annegas*.

The HENNEGA is 12 *Almudas*.

The ALMUDA weighs 7 lb, 9 *Oun.* 14 *Ang.* and about 24 *Gr.* of *Amsterdam Weight*, and the *Almuda* is exactly $\frac{1}{11}$ of the *Amsterdam Achan* or *Last* of *Rye*, that weighing, as we shall take Notice hereafter, 4200 lb.

CAVESGO is $\frac{1}{17}$ of the *Amsterdam Last*, and consequently weighs 262 $\frac{1}{2}$ lb of *Amsterdam*.

Portuguese Liquid Measure.

The ALMUDA contains 12 *Canadas*.

The CANADA - - - 4 *Quartas*.

The QUARTA is equal to the *Quartilla* of *Spain*, which weighs 1 lb of *Antwerp*, consequently the whole *Almuda* weighs 48 lb of *Antwerp*.

The ALQUIER or CANTAR is $\frac{1}{3}$ of the *Almuda*, and holds 6 *Canadas*, which are 4 *Antwerp Stopes*, or 24 lb *ditto*. With this they measure *Oil of Olives*.

The QUARTILLA is 13 $\frac{1}{2}$ *Cantres*.

The STAR is a *Liquid Measure* used in *Algarva*, weighing 59 lb, 10 *Oun.* 15 *Ang.* and 26 *Gr.* or thereabouts.

Dry Measure of the same Nation.

The MOI	holds 15 Fangas.
The FANGA	--- 4 Alquiers.
The ALQUIER	--- 2 Mejos, which are half Measures.
The MEJO	--- 2 Quartas.

Observe here, that 225 *Alquiers* are equal to a *Last of Amsterdam*, and consequently that the *Alquier* weighs 18 lb, 10 Oun. 13 Ang. and 10 Gr.

French Liquid Measure.

The MUID, QUARTAL, or CASQUE of Paris, holds 2 *Filets, Barriques, or Barrels.*

The FILET	holds 18 <i>Sestiers.</i>
The POT or QUART	--- 2 <i>Pintes.</i>
The PINT	--- 2 <i>Chopines or Hemines.</i>
The CHOPINE	--- 2 <i>Demi-Sestiers.</i>
The DEMISESTIER	--- 2 <i>Poffons.</i>

From all this it follows, that the *Muid of Paris* contains 288 *Pintes*; and this it does, by an Order of *Lewis XIII.* But, in pursuance to the Orders of *Henry the Great*, it ought to contain 300 *Pintes.* Now it will be very easy to equalize these two, by taking away 12 *Pintes*, which ought to be allowed for the Lees of Wine. Hence you may readily know the Weight of a *Tunn of Wine.* For, as by the Observations of *Mersennus*, it appears that the *Pinte* weighs 2 lb, it will follow that the *Tunn or Muid*, which contains 288 of those *Pintes*, will weigh 576 lb. But if we admit of the Lees, it will weigh 600 lb over and above the Weight of the Vessel itself, which is not to be reckoned. *Mersennus* has described the Form and Size of the *Muid* after this manner in Prop. IV. of his Book of *Measures, &c.* "It has the resemblance of a *Cylinder*, " or rather of a double *Cylinder* truncated, with equal Bases, from " whence this Vessel is more capacious or broader in the Middle than " towards the Ends; its Length (says he) or interior Height, is 2 " Feet and 10 Inches, and in the Middle it is 2 $\frac{1}{2}$ Feet, and towards " the Bottom or Bases 2 Feet only.

The *Casque or Muid of Paris* holds 78 *Stopes of Antwerp*, and sometimes 77, that is, 312 *Pints*, or 308: It weighs 468 or 462 lb of *Antwerp*; since (as we have already said) the *Stope* weighs 6 lb, the *Pint* which is $\frac{1}{2}$ of it ought to weigh 1 $\frac{1}{2}$ lb; and from this we may easily determine the Proportion between the *Parisian* and *Antwerpian Pound.*

They have another *Liquid Measure* in France, which the French call a PIPE; this holds 2 *Muids of Paris*, and consequently weighs 1200 lb.

Dry Measure of the same Nation.

The MUID, or GREAT MUID holds 2 *Tonneaux* or *Tuns*, or 12 *Sefiers*.

The TONNEAU is $\frac{1}{2}$ the *Muid* or 6 *Sefiers*.

The SESTIER is $\frac{1}{12}$ of the *Muid*, and $\frac{1}{2}$ of the *Tonneau*, and is divided into 2 *Mines*.

The MINE is 2 *Minots*.

The MINOT contains 2 other small *Measures* commonly called *Boisseaux* or *Bushels*.

The BOISSEAU or BUSHEL, according to *Mersennus*, holds 16 lb of Wheat, when it is heaped up without shaking or squeezing it down. The Heap, (or what is above the Rim of the *Measure*) according to the same Author, weighs 3 $\frac{1}{2}$ lb; thus when the *Boisseau* is striked there will remain 12 $\frac{1}{2}$ lb in it. Suppose now that the *Muid* contains 96 *Boisseau*, we may naturally conclude that such a *Muid* full of Wheat would weigh 1536 lb.

The same *Mersennus* assures us he found by Experiment, that there are 860 Grains of Wheat in the Ounce of a *Pound*, taking them promiscuously from any Heap or Parcel without picking or choosing; consequently the *Pound* will contain 13760 of those Grains, and the *Boisseau* when heaped up 220160 Grains, but if striked but 172000 only.

The *Boisseau* or *Bushel*, according to the Orders of Lewis the XIII. *E. 1. Titre 10.* ought to contain 18 lb, 6 Ounces, and 8 Scruples of Wheat; and in the same Place the great *Muid* is ordered to weigh 2640 lb.

They have a kind of *Dry Measure* at *Roan*, which they there call POINSON, and which holds 13 *Boisseaux*.

In *Brittany* they have another, which they call a LOAD, it contains 4 *Boisseaux*, and 10 of those *Loads* make a *Pipe*, which is 600 lb of *Amsterdam*; 7 *Pipes* or 70 *Loads* answering exactly to the *Amsterdam Last* of Rye.

Italian Liquid Measure.

BRENTA or AMPHORA is properly a *Liquid Measure*, used by the *Romans* at this Day; it contains 96 *Boccales*, and is divided into 13 $\frac{1}{2}$ *Robas* or *Stones* each of which weigh 10 lb, but these *Pounds* are of 30 Ounces each. The *Brenta* is equal to 42 *Stopes* of *Antwerp*, by which means it must weigh 252 lb.

BOCCALE contains 2 *Mezzoboccale*.

BARILE, BARIL or CASK is a *Tuscan Liquid Measure*, which holds 20 *Italian Bottles* which they call *Fiasco* or *Flasks*; 18 *Stopes* of *Antwerp* make a *Baril* which weighs 108 lb of *Antwerp*. As for the *Fiasco*

64 Of the Great Art of ARTILLERY.

Fiasco or *Flask*, it weighs 5 lb, 6 Ounces, and 3 Drams, or thereabouts.
Item, 3 *Barils* make a *Staar*.

STAAR is a *Measure* containing 54 *Stopes* of *Antwerp*, and therefore must weigh 324 lb.

MOSTACHIO, or MOSTACIO is a *Candian Measure*, which holds 3 *Stopes* and $\frac{2}{3}$ of *Antwerp*, and weighs $22 \frac{1}{3}$ lb.

BOTTEL is another *Measure* which holds 34, 35, and sometimes 38 *Mostachios*.

BOTTA is a *Venetian Measure* of 38 *Mostachios*, which they also call *Zechi*, and in some Places *Gantari*; 76 *Mostachios* make a *Brenta* or *Amphora*.

BIGONCIO or CONGIUS, is in the same Place a *Measure* of 4 *Quarters*. You must have 18 *Stopes* of *Antwerp* to fill a *Quarter*; it weighs 108 lb, and is equal to the *Roman Barile*. The *Bigoncio* is equal to 72 *Stopes* of *Antwerp*, and weighs 432 lb.

SECCHIO, which the *Latins* called *Hydria*, is 15 *Stopes* of *Antwerp*. This is a *Measure* particularly used by Merchants who carry on an Inland Trade; but the preceding *Measure* is in request amongst such as are concerned in Shipping, and who cultivate a Transmarine Commerce.

AMPHORA, in the same Country, is an *Oil Measure*; it is 4 *Bigoncios* or *Congii*, each of them being 4 *Quarters*. This *Measure* is equal to 2 *Bottas*, each *Botta* 38 *Mostachios*.

MIGLIARIO is a *Measure* much in Vogue throughout all *Italy*. At *Venice* it weighs 1210 lb. At *Verona* 1738 lb, and is equal to 8 *Brentas*, and 11 *Basses*: As for the *Brenta* it is divided into 16 *Basses*. At *Pavia* the *Migliario* weighs 1185 lb, which are equal to $831 \frac{1}{2}$ lb of *Antwerp*. At *Vincenza* it is as at *Venice*. At *Tervisa* 1117 lb.

Besides these *Liquid Measures*, I have been speaking of, they have still others, (*viz.*)

The MASTELLO, CARA, CONSI, 10 of which make a *Cara* of *Tervisa*.

The SALM is a *Measure* used in *Puglia* and *Calabria*; it makes 10 *Staars*, each *Staar* 32 *Pignateles* or *Ollules*. This *Salm* is equal to the *French Filet*, or to the half *Quartal* of *France*. It answers to 39 *Stopes* of *Antwerp*, and commonly weighs 234 lb.

Dry Measure of the same Nation.

QUADRANTAL is 3 *Roman Modii*, the *Modius* 8 *Hemina*, the *Hemina* 2 *Sextarii*. This *Quadrantal* weighs 52 lb, and 8 Ounces, of *Amsterdam Weight*; 80 *Quadrantals* making an *Amsterdam Last*.

STAR is a *Sea* or *Naval Measure* amongst the *Venetians*, and weighs 131 lb and $\frac{1}{2}$; 32 *Stars* exactly answering to the *Amsterdam Last* of *Rye*; but 14 of them constitute a *Last* of *Barley*.

Again;

Of the Great Art of ARTILLERY. 65

Again; the AMSTERDAM LAST is equal to 80 Stars of Mantua; to 32 of Medina; to 96 of Pavia; to 112 of Florence; to 102 of Vincenza; to 32 of Zarenza; to 48 of Ravenna; and to 29 of Terovisa.

MOSA or MODIUS is a Venetian Measure, $7\frac{1}{2}$ of which are equal to an Amsterdam Last. In some other Places it is divided into 14 Pefos, each of which weighs 10 lb, each Pound containing 30 Ounces; in other Places it is divided into 4 Degalatro, or into 16 Sesterces or Sextarii.

CORBA, among the Italians, is what the Latins formerly called Corbis or Corpinus, and in English may be called a Basket. This is a Dry Measure. At Bologna it is equal to the Venetian Star, 32 of these Corbas being equal to a Last of Amsterdam.

MEDIMNUS, a Dry Measure in Sicily, contains 6 Modii, and each Modius 16 Sextarii or Sesters. The Medimnus weighs 100 lb, 8 Ouz. and 3 Dr. or thereabout of Amsterdam Weight; so that 38 Medimni are exactly an Amsterdam Last.

Moreover the Medimnus, in the Island of Cyprus, is divided into 2 Cypra or Cypruses, or 4 half Cypra; and 40 of these Medimni are equal to an Amsterdam Last.

In the same Place they divide the Modius into 16 Gabenes, Sesters or Sextarii; 2 Modii make a Pontick in that Country.

MINA or MINALI is a Dry Measure at Genoa and Verona; $23\frac{1}{2}$ of these Measures are equal to an Amsterdam Last at Genoa; but at Verona it will require 72.

SOMA in Brescia is also a Dry Measure; 16 of these constitute a Last of Amsterdam.

SALM, a Dry Measure in Sicily, holds 16 Tumans; it is sometimes of two sorts, (viz.) the smaller and greater; 10 of the former and 8 of the latter constitute an Amsterdam Last.

The CARA in Puglia answers exactly to the Venetian Star. This Measure is of two sorts, that with which they measure Rye, containing 36 Tumans, but of Barley it holds 48 of the same above mentioned. Thus the Cara weighs $131\frac{1}{2}$ lb of Amsterdam. In short, 32 Caras of Rye and 24 of Barley constitute a Last of Amsterdam.

German Liquid Measure.

RHUTHE holds 2 $\frac{1}{2}$ Fuder.

FUDER, in Latin *Veves*, is 6 Amphora, which are commonly called *Amer*, at all the following Places of Upper Germany, (viz.) Cologne, Worms, Ulm, Frankfurt upon the Main, Oppenheim, Wirtzburg, Mayance, and at Wirtemberg: But in other Places it holds 10 *Amer*; as at Heidelberg and Spire; at Vienna, and all over Austria; 16 *Amer* or Amphora make a Culeus. Again; at Falkenberg, Duerheim, and at Augsburg, 8 *Je* or *Amer* make a Culeus.

66 Of the Great Art of ARTILLERY.

OHM or AME, which the *Latins* called *Amphora*, holds 20 *Quarts*, or 80 *Measures*, which, in the Language of the Country, are called *Maffen*; or 2 *Urns*, which they call *Eimer*. Those who have been at *Cologne*, *Worms*, *Leipsick*, *Francfort* upon the *Main*, *Ulm*, *Oppenheim*, *Mayance*, *Noremberg*, *Wirtzburg*, or *Vienna* in *Austria*, may know this. But at *Heidelberg*, and at *Spires*; they divide the *Ame* into 12 *Quarts*, and the *Quart* into 4 *Measures* or *Kans*. Moreover, at *Falkenheim* and *Durcheim* they divide the *Ame* into 15 *Quarts*, of 4 *Kans* each. Then at *Wirtemberg* they reckon 16 *Innes* in the *Ame*, each of which is 10 *Kans*. In *Augsburg* 2 *Modii* or 12 *Besontz* make an *Ame*: To conclude; in some other Places they reckon 60, 64, and 72 *Kans* in the *Ohm* or *Ame*.

EIMER, by the *Latins* *Urna*, at *Noremberg*, *Wirtzburg*, and generally throughout all *Franconia*, is divided into 64 *Kans*; at *Vienna* in *Austria* into 32 *Octaves*, or 128 *Seiltem*; at *Sabone* and *Brixem* 144 *Kans* make an *Urn* or *Eimer*, and but 8 only constitute a *Parcede*.

The EIMER or URN in *Misnia*, and generally throughout all High *Germany*, weighs 36 *lb*: But at *Leipsick* it is 40 *lb*; and is divided into 3 *Stubecken*; and again into 4 *Cantres* or *Kans*, or (as they likewise have it) *Maafs*; and each of these *Kans* are 2 *Nossels* or *Quarts*. The *Nossel* is 2 *Pints* or *Heminæ*, which they call *Halb Karter*, and the *Halb Karter* is 2 small *Measures*, which they call *Mafslein*.

MAAS or KAN, as it is called by the High and Low *Dutch*, and by the *Latins* *Cantharus* or *Congius*, is almost of the same Bigness in all the Towns in High *Germany*. We have already said enough of the Subdivisions of these *Measures*; let us now examine their Weight. In *Germany* the Pound is of two sorts, the *Mensural* and *Ponderal*, as we have already observed; so that at *Leipsick* 23 *Mensural Ounces* make but 26 $\frac{1}{2}$ *Ponderal Ounces*; but every where else in *Misnia* 24 *Mensural Ounces* are equal to 20 *Ounces Ponderal*; that is, they are to one another as 12 to 10, or as 6 to 5, after the manner of the *Antient Romans*. This being laid down, the *Ohms* or *Ames* of *Worms*, *Francfort*, *Ulm*, *Oppenheim*, *Cologne*, *Wirtemberg*, *Mayance*, *Heidelberg*, *Spires*, *Strasburg*, *Falkenheim*, and *Durcheim*, containing 80 *Congii* or *Kans*, will be equal to the *Antwerpian Ame*, of 50 *Stopes*, which (each *Stope* being 6 *lb*) weighs 300 *lb*, and consequently the *German Pot* or *Kan* must weigh 3 *lb*, 12 *Oun.* of *Antwerp*. By this means we may readily come at the Weight of the *Eimer* or *Urn*, as well as at that of the *Fuder*, *Rbuth*, and smaller *Measures*, &c.

Again; 128 *Kans* of *Noremberg*, *Wirtzburg*, *Franconia*, *Vienna*, and *Augsburg*, weigh 300 *lb* of *Antwerp*, and each of them apart weighs 2 *lb*, 5 *Oun.* and $\frac{1}{2}$ of the same.

The BEER TUNN of *Lubeck* is equal to the *Ame* of *Antwerp*, 50 *Stopes* of *Antwerp* exactly filling a *Lubeck Tunn*.

Dry Measure of the same People.

The LAST, as the *Germans* call it, or as the *Latins* have it (from the *Greek*) *Achane*, is properly the Lading of a Vessel or Ship. At *Hamburg* it is 3 *Wispel*, each of which contains 30 *Modii*, or *Scheffel*, as they call them: Now the *Scheffel* weighs 52 lb, 9 Ounces, 12 *Ang.* and 22 *Gr.* or thereabouts of *Amsterdam*; and therefore a *Last* of 3 *Wispel*, or 90 *Scheffel* or *Modii*, will weigh 4734 lb, 3 *Oun.* 1 *Ang.* and 28 *Gr.*

Observe here that this *Wispel* is equal to 6 *Antwerpian Ames.* Again, 83 *Scheffel* of *Hamburg* are equal to an *Amsterdam Last*. At *Rostock* and *Lubeck*, 96 *Scheffel* make their own *Last*; but 85 of them are equivalent to the *Last* of *Amsterdam*. At *Stetin* in *Pomerania* 72 *Modii* or *Scheffel* constitute their own *Last*, $\frac{1}{4}$ of which is equal to that of *Amsterdam*.

SCHIFFPFUNDT is a *Sea Measure* much used by those who border upon the *German Ocean*, and *Baltick Sea*. It is properly a certain part of the *Last*, which comes near to the *Medimnus* of the *Romans*, or to the great *Medius*, or rather to the *Trimedimnum* which we have spoken of already. This is equal to the *French Load*, or the *Spanish Cargo*, or the *Italian Carco* or *Carico*. With this they not only measure all sorts of Grain, but also several other Species of Goods. At *Hamburg* it is divided into 20 *Lispfundt*, and weighs 300 lb. At *Lubeck*, *Copenhagen*, and *Stockholm*, 20 *Lispfundt* make a *Schiffpfundt*, which weighs 320 lb. But I shall forbear speaking here of the Weight and Capacity of this *Measure*, (it being to be explain'd hereafter) in a vast number of other Places where it is in use.

LISPFUNDT is an Aliquot Part of the *Schiffpfundt*, as may be seen above, and may properly be called a *Sea Measure*. At *Hamburg* it weighs 15 lb; at *Lubeck* 16 Marks, and at *Stralsund* 16 lb.

MALTER or MOLDER does not differ very much from the *Schiffpfundt* in Weight and Capacity. It is a kind of *Land Medimnus*, which is used among the Merchants of certain Towns in High *Germany*. For Example; in *Misnia* it holds 16 *Modii*, each of which weigh 20 lb; therefore the *Malter* weighs 320 lb in that Place. At *Vienna* and all over *Austria* it is composed of 32 *Modii* which they call *Atschel*, or 64 *Halb Atschels* or *Spinten*. Suppose now that this *Modius* weighs 21 lb and 14 *Oun.* of *Amsterdam*, the *Malter* will weigh 600 lb, and consequently 6 of them would be equal to a *Last* of *Amsterdam*. At *Cologne* upon the *Rhine* 18 *Medimni*, or *Malters*, are equal to the same, supposing each of them to weigh 233 lb, 5 *Oun.* 6 *Ang.* and 2 $\frac{1}{2}$ *Gr.*

68 Of the Great Art of ARTILLERY.

Liquid Measure of the Low Countries.

ROEDE is a Measure which answers to the half *Culeus* of the *Romans*. At *Dort* it is 10 *Ames*.

The AME is 10 *Schrewes*, and has some Affinity with the *Roman Amphora*.

The SCHREWE is 10 *Stopes*; this Measure does not vary much from the *Roman Urn*.

The STOPE agrees nearly with the *Congius* of the *Romans*, and holds 2 *Kannes* or *Pots*, which in some Places are called *Mengel*.

The KANNE, POT, or MENGEL, does not greatly differ from the *Roman Sextarius*, and holds 2 *Pints*.

The PINTA or PINT may be properly called *Hemina* in *Latin*, it being half of the *Kanne* or *Sextarius*.

Then 10 *Ames* of *Dort* are $14 \frac{2}{3}$ of those of *Antwerp*, of 50 *Stopes*; each *Stope* weighing 6 lb of *Antwerp*; and the *Roede* or *Rods* of *Dort* will weigh 4400 lb, and consequently the *Ame* will weigh 440 lb; the *Schrewe* 44 lb; the *Stope* 4 lb, 6 Ounces, 8 Ang. the *Kanne* 2 lb, 3 Ounces, 4 Ang. and in short the *Pint* must weigh 1 lb, and 12 Ang. of *Antwerp*.

This *Roede* is again divided into 2 *Tuns*, each of them containing 500 *Stopes* of *Dort*, or 2200 lb; to which if you add 50 lb for the Weight of the *Tun* itself, it will, when full of Wine, weigh 2250 lb, and consequently 2 *Tuns* will weigh 4500 lb. Hence it is that in loading a Ship they reckon 2 of these *Tuns* equal to a *Last* of Wheat.

Again; 14 *Ames* of *Amsterdam* are equal to 10 *Ames* of *Dort*; but we must here observe that the *Amsterdam Ame* is divided into 64 *Stopes*; therefore it weighs but 314 lb, 4 Ounces, 5 Ang. and 22 Gr. or thereabouts of *Antwerp*; each *Stope* weighing 4 lb, 14 Ounces, 2 Ang. and about 10 Gr. In *Friseland*, the *Ame* is 40 *Kannes* or 160 *Mengels*. At *Malines* in *Brabant* it is 80 *Mengels*; whence it appears that the *Mengel* of *Malines* is double of that of *Friseland*, and that what they call a *Pint* at *Malines* is a *Mengel* or *Pot* in *Friseland*; but as to the *Ame* of *Malines* or *Friseland*, as well as of *Louvain*, *Brussels*, *Boisleduc* and *Breda*, they are equal in Weight and Capacity to the *Ame* of *Antwerp*: But the *Mengel* of *Louvain* is equal to the *Maafs* or *Kan* of the *Germans*. The *Ame* at *Brussels* and *Louvain* is divided into 48 *Stopes*; at *Boisleduc* into 50; at *Leyden*, *Delf*, *Trevers*, *Flushing*, *Middleburgh* in *Zealand*, *Ghent*, *Bruges* in *Flanders*; and at *Liege*, it is divided into 60 *Stopes*. Again, 50 *Stopes* of *Antwerp* are equal to 54 of the *Hague* and *Ruremond*; to 72 of *Ziriczee*, and to 26 of *Newport* and *Osford*. I shall add to all this, that $14 \frac{2}{3}$ *Ames* of *Bruges*, *Middleburgh*, *Trevers* and *Flushing* are equal to 16 *Ames* of *Dort*.

Besides,

Of the Great Art of ARTILLERY. 69

Besides this *Road* which we have been speaking of, they have one of another sort at *Bruges*, which holds 2 *Vessels* or *Tunns*, each of 22 *Sextarii*, or *Sefers*, each of which is 16 *Stopes*.

The *TUNN* of Beer throughout all *Brabant*, contains 54 *Antwerp Stopes*; but in *Flanders* 60, and sometimes 64 *Flemmish Stopes*. As for the *Dutch Tunns* it is equal to that of *Brabant*, except that of *Amsterdam*, which requires 56 $\frac{1}{2}$ *Stopes* of *Antwerp*. As to the rest, I shall not reduce them to the *Weights*, since any body may do it by knowing the Weight of the *Antwerpian Stope*.

Dry Measure of the same People.

The *LAST* or *ACHANE*, when it is used to measure *Wheat*, is composed of 16 *Sea Medimni*, which the *Dutch* call *Schippont*, each of which weighs 300 lb; therefore the whole *Last* weighs 4800 lb; but when they measure *Rye* 14 *Schipponts* make a *Last*, each of which are equal to the former in Weight and in Capacity, consequently a *Last* of *Rye* will weigh 4200 lb of *Amsterdam*. At the same place, they reckon 27 great *Measures*, which they call *Mudden*, in a *Last*; each of these *Mudden* contains 4 smaller *Measures*, which they call *Schepelen* or *Busbels*; therefore the *Last* is 108 *Schepelen* or *Busbels*. Again; they compute 29 *Sacks* in a *Last*, each *Sack* of 3 *Octaves*, or *Abtelingen*, as they have it. Moreover, 24 *Salt Casks*, or 21 $\frac{1}{2}$ of those narrow *Vessels* in which *Flower* is stowed, or 15 $\frac{1}{2}$ of the larger and broader of the same kind, constitute exactly a *Last* of *Rye*; again, 18 *Tunns* or *Vessels* of Beer, or as many *Ames* of *Antwerp*, answer to the same thing. Now these two last, make 3 *Tunns* of *Wine*, but 2 *Tunns* only are reckoned equivalent to a *Last* of *Rye*; because 2 of them weigh 4200 lb or thereabouts; for suppose that the *Quadrantal* or *Cask* of *Wine* weighs 500 lb; 2 *Tunns* or 8 *Quadrantals* will consequently weigh 4000 lb; and 3 of the like *Tunns* or 12 *Quadrantals* full of *Rye*, will weigh 4200 lb (without reckoning the Weight of the *Vessels* themselves) each of them containing about 360 lb of *Rye*. But we must take notice that all sorts of *Grain* do not always weigh alike; and the *Amsterdam Last* of *Wheat* has been found sometimes to weigh 4800 lb, and at other times but 4200 lb; and a *Last* of *Rye* weighs sometimes 4200 lb, and at other times but 4000 lb. Try a *Last* of *Barley*, and you will find that it weighs but 3400 lb; and *Oats* will weigh still less; for which reason it has been customary in some Places, to have a more capacious *Measure* for *Oats* than for *Rye*. Now since according to the Observations of *Mersennus* the *Parisian Pound* contains 13760 Grains of *Wheat*, which *Pound* is 16 Grains lighter than the *Amsterdam Pound*, this latter will contain 13776 lb, and the *Last* weighing 4800 lb, will certainly contain 66,124,800 of the same Grains. At *Hembden* 15 $\frac{1}{2}$ *Tunns*, of 4 *Werpen* or *Busbels* each, constitute a *Last* of their own; but 55 *Werpen*

70 Of the Great Art of ARTILLERY.

answer to a *Last* of *Amsterdam*. At *Antwerp* the *Last* is 32 *Quarters*, and the *Quarter* 4 *Bushels*, or *Muckens*, as they call them; thus 38 *Quarters* are equal to a *Last* of *Amsterdam*. At *Rotterdam* 3 *Oftaves* or *Eighthths* make a *Sack*, and 38 *Sacks* make the *Last* of that Place; but 87 *Oftaves* are equivalent to an *Amsterdam Last*.

The **MUDEDE**, or great **MODIUS**, is divided at *Louvain* into 8 smaller *Measures*, called *Halster*; 13 of these are equal to a *Last* of *Amsterdam*, as are also $10\frac{1}{2}$ of *Brussels*, 7 of *Maestricht*, and $12\frac{1}{2}$ of *Boisleduc*. At *Ghent* the *Mudde* is divided into 6 *Sacks*, the *Sack* into 2 *Halsters*, the *Halster* into 2 *Quarters*, and the *Quarter* into 2 *Muckens*: Now 4 of these *Muddes* and 7 *Halsters* make 1 *Last* of *Amsterdam*. At *Bruges* they call this *Measure* an *Hoet*, which they divide into 4 *Bushels*, the *Bushel* into 4 *Quarters*, the *Quarter* into 2 *Spintes*: $17\frac{1}{2}$ of these are exactly a *Last* of that Place; but the *Amsterdam Last* requires $17\frac{2}{3}$ of them. At *Ypres* 12 *Razieres* give a *Mudde*, each *Raziere* answers to 4 *Tunns* of that Place, and 25 *Razieres* make a *Last* there: Again; 75 of these *Razieres* constitute a certain great *Measure* called *Ikink*, which is treble of the *Last*. In short, they reckon 24 *Razieres* to an *Amsterdam Last*. In several other Places of less note in *Flanders* the *Raziere* is divided into 4 *Awots*, the *Awot* into 4 *Pints*, and the *Pint* into 8 lb. At *Lewarden* in *Friesland* the *Mudde* is 2 *Lopen*; 36 of these are an *Amsterdam Last*. At *Middleburgh* in *Zealand* the *Mudde* or great *Modius*, which they call *Hoet*, is composed of 16 *Sacks*; which may be properly called 8 *Razieres*, $41\frac{1}{2}$ of which constitute a *Last* of that Place, and 40 of them answer to that of *Amsterdam*. At *Dort* the *Hoet* is 8 *Tunns*, and 3 of these *Hoet* (which are a kind of *Schiffsfundt*) are exactly the *Amsterdam Last*.

Polish Liquid Measure.

BECZKA, in *Latin* **DOLIUM**, and in *English* a **TUNN**, ought (in pursuance to an Order to that Purpose in the Year 1565) to contain 72 *Congii*, or *Kanns*, which the *Poles* call *Garniec*. But by an Order issued out afterwards in the Year 1598, it is to contain but 62 *Garniec*.

The **TUNN**, or Beer-Vessel of *Dantzick*, contains 180 *Dantzick Stopes*. It has been found at *Antwerp* that 180 of these *Stopes* make but 81 of their *Stopes*, and from thence we conclude, that the *Dantzick Tunn* weighs 486 lb of *Antwerp*; and a *Dantzick Stope* weighs exactly 2 lb, 11 *Oun.* and 4 *Ang.* of *Antwerp*; and the half of it, which they call *Halb*, weighs 1 lb, 5 *Oun.* and 12 *Ang.* From this we may infer that the *Stope* of *Dantzick* is 4 *Antwerp* Ounces, and 16 *Anglicks*, less than the *Pot* or half *Stope* of *Antwerp*. Besides this; I know that the *Polish Garniec* contains about 2 *Dantzic Stopes* of *Liquor*; therefore the *Polish Tun* of 62 *Garniec* or *Congii*, is 56 *Dantzic Stopes* less than that of *Dantzic*; that is, that the *Dantzic Tun* contains more than that of *Poland*

land by 28 of its own *Garniec*. Let us now conclude that the *Polish Garniec*, weighing 5 lb, 6 Ounces, and 8 Ang. of *Antwerp*, does not differ much from the *Roman Congius*, as we have above described it; and I firmly believe, that those who first instituted the *Polish Garniec* designed it should be equal to the *Roman Congius*: But as all sublunary Things are subject to Revolution and Vicissitude, as they pass through a long Succession of Years; it is no wonder that this Measure has varied a little from its first Dimensions, and suffered some small Diminution. To conclude; since the *Polish Tun* of 62 *Garniec* weighs 334 lb, 12 Ounces, and 16 Ang. of *Antwerp*, it will be equal to $\frac{1}{4}$ of the *Dolium*, or to 7 *Roman Amphora*. As to the *Weights* of the half *Garniec*, which the *Poles* call *Pulgartca*, and the $\frac{1}{4}$ of that which is called *Kwarta-garcowa*, it will be needless to enlarge upon them, after so much has been said.

The *OHMA* of *Dantzic* holds 110 *Dantzic Stopes* of Wine, or 20 *Quarts*, reckoning the *Leas*; but disallowing of them, it will be but 104 *Stopes* and $\frac{1}{2}$, or 19 *Quarts*.

WIARDO is a Measure very well known in that Country, and contains 20 *Garniec*, *Congii* or *Kannes*.

Dry Measure of the same Nation.

LASZT, or *LASTE*, is a Measure much in vogue in *Poland*, *Livonia*, *Prussia*, and *Lithuania*, and all the circumadjacent Provinces. It is used indifferently by Merchants concerned in Sea Trade, and Dealers in Inland Cities and Towns: With this, they not only measure all sorts of Grain, but all manner of Merchandize both *Liquid* and *Dry*: Or at least they understand by a *Laszt*, a certain Quantity of any thing of a particular Weight; as for Example; the *Laszt* of Flax or Hemp at *Dantzic* weighs 60 *Stones*, or 2040 lb of *Dantzic*. Again; a *Laszt* of Hops is 12 *Schiffsfundt* or *Sea Measurs*, or 3830 lb of *Dantzic*. A *Laszt* of Flower, Honey, Mead, Beer, Ashes, Tar, and Pitch is 12 *Tunns*; but 18 is a *Laszt* of Salt. As to Wheat and other Grain, the *Laszt* almost throughout all *Poland* is divided into 60 Measures which they call *Korsec*; but we meet with it of very various Capacity, and very different Weight. At *Dantzic* the *Laszt* of Rye is 15 *Schiffsfundt*, each of which contains 4 Measures which we have elsewhere called *Scheffel*, each of which holds 16 smaller Measures called *Matzen*. In the same Place a *Laszt* of Wheat is 26 *Schiffsfundt*; but this difference must be allowed for the different Weight of Wheat, which is much heavier than Rye; for both of them consist of 60 *Scheffel*. It has however been observed that the *Dantzic Laszt* of Rye weighs 4245 lb of *Amsterdam*, though it weighs 5100 lb of *Dantzic* itself. For the *Schiffsfundt* weighs 340 lb of *Dantzic*, containing 10 *Stones* of 34 lb each; but the other which is of a smaller Kind, and contains but 20 *Liffsfundt*, weighing each 16 lb of *Dantzic*, is used in weighing all other Commodities. Again; a *Dantzic*

zic Lafzt of Wheat weighs 6440 lb, from whence we may gather the Weight of the *Dantzic Scheffel* or *Modius*; for it being $\frac{1}{2}$ part of the *Lafzt*, it will weigh 85 lb with regard to Rye, and with regard to Wheat it weighs 90 lb, 10 Ounces, 5 Quart, and $\frac{1}{2}$ Pond. Nom. At *Koningsberg*, and at *Ebbing* the *Lafzt* weighs 6400 lb, and consists of 16 *Schiffsfundt*, each of which weighs 400 lb, or 20 *Liffsfundt*; and 6 of these make 7 *Lasts* of *Amsterdam*. At *Riga*, *Revel*, and *Narva*, 12 *Schiffsfundt* of 10 Stone, or 400 lb each, constitute a *Lafzt* weighing 4800 lb of those Places, and but only 4000 lb of *Amsterdam*.

KLODA and **MACKA** is a kind of *Dry Measure* much used in the Lesser *Poland*, and *Red Russia*; that is, about *Lemburg*, *Premislitz* or *Premislaw*, and *Jaroslaw*, extending towards the *Carpathian* or *Krapakian* Mountains; it contains 4 *Modii* or *Quartes*, or 8 half *Modii* commonly called *Pulmiarek*; or into 16 *Macka*, or 32 *Pulmarek*; now at *Lemburg* the *Pulmarek* is equal to 4 *Polish Garniec* or *Congii*, and the whole *Macka* to 128 of the same. From this it is evident, that $\frac{1}{2}$ of this *Measure* is equal to the *Old Roman Urna*, and consequently that it answers in all to 32 *Urns*, or 1280 lb *Roman*. The *Macka* in *Jaroslaw* is 160 *Congii* or *Garniec*, (*Kann*) but at *Premislitz* 130 only.

CWERTNIA is a *Measure* which may properly be called a *Bimedimnum*; for it holds two *Medimni* or *Korzec* of *Cracow*. At *Pozna* it is 42 *Congii* or *Garniec*. At *Kaliskie* 36 *Garniec*, and the *Wiertel Kaliski*, is 14 *Congii* or *Kann*.

KORZEC is exactly the *Medimnus* of the *Latins*; that of *Cracow* is 16 *Congii*; by which means it happens to be equal to the *Medimnus* or 2 *Amphora*, and answers to 160 lb *Roman*. Its $\frac{1}{2}$ part answers to the *Old Roman Urn*, or the *Seab* of the *Hebrews*. In *Lublin* it is 28 *Congii*, and this does not differ much from the *Old Roman Decimodium*. That of *Sandomiria*, and *Warsaw*, is 24 *Congii*, and 12 the half of them will be equal to an *Attic Amphora*, if we believe *Fannius*: And *Villalpandus* assures us, it will not differ much from the *Roman Hydria*; nor from the *Metreta*; moreover $\frac{1}{2}$ of this *Measure* comes nearly to the *Grecian Amphoreus*; and $\frac{1}{4}$ of it is not much less than the *Latin Modius*.

BECZKA or **TUNN** is the *Dolium* of the *Latins*: With this they measure *Dry Things* in *White Russia* and *Lithuania*. This Vessel contains in Wheat or any other Grain almost 2 *Salt Casks*, if heaped up and pressed down; it weighs about 350 lb of our Parts: This is the *Measure of Pilsa*: That of *Smolensko* is $\frac{1}{2}$ of this, and consequently weighs 525 lb. Besides the *Measures* I have already mentioned, there are several others in *Poland*, *Lithuania*, and *Russia*, of lesser Capacities; such as the *Mirka*, *Szaneh*, *Qsmaczka*, &c. but these I shall pass over without farther Notice, not only because they are not in such general Use as the rest; but also for fear of growing tiresome to the Reader, who is commonly fond of Brevity. I shall only observe to you once more, that the Weight of all these *Measures* may vary, according to the different Specifick Gravity of Grain.

English

English Liquid Measure.

The Gallon contains 2 Pottles.

The Pottle ——— 2 Quarts.

The Quart ——— 2 Pints.

The Pint weighs one lb of *Troy Weight of England*, and consequently the Gallon will weigh 8 of the same. Now in order to know what Proportion this Pound bears to the others we have mentioned, please to turn back to what we have said in the Chapter of *Weights*. Again ;

- 8 Gallons make 1 Firkin, 64 lb.
- 16 Gallons ——— 1 Kilderkin, 128 lb.
- 18 Gallons ——— 1 Rainlet, 148 lb.
- 32 Gallons ——— 1 Barrel, 256 lb.
- 42 Gallons ——— 1 Tierce, 336 lb.
- 63 Gallons ——— 1 Hogshead, 504 lb.
- 126 Gallons ——— 1 Pipe, 1008 lb.
- 252 Gallons ——— 1 Tun, 2016 lb.

These are their *Strong Beer and Ale Measures*. The following are for the same. *N. B.* All the Subdivisions of these, from the Pint to the Gallon, are of the same Weight with those of the former.

- 9 Gallons make 1 Firkin, 72 lb.
- 18 Gallons ——— 1 Kilderkin, 144 lb.
- 36 Gallons ——— 1 Barrel, 288 lb.

The *Beer Gallon* in the *Low Countries* is a *Stoop*, except at *Amsterdam* and *Antwerp*, where it is but 1 1/3 *Stoop*.

Dry Measure of the same Nation.

A *Wag* holds 9 Quarters.

Quarter — 8 Bushels.

Bushel — 4 Pecks.

Peck — 2 Gallons.

The GALLON, as we have already said, weighs 8 lb ; therefore the *Wag* will be 360 lb.

They moreover reckon 4 *Bushels* in an *Halfster*, which is about a *Sextarius*, and 20 1/2 *Halfsters* make a *Last*.

In *Corwall* 20 Quarters make a *Score*.

In *Ireland* and *Scotland* the *Bushel* is 18 Gallons.

74 Of the Great Art of ARTILLERY.

Liquid Measure of some Eastern Nations.

MATALI or MATARI a *Measure* in the Kingdom of *Tunis* which holds 36 *Rotules*: It answers to about 5 *Antwerp Stopes*; and 10 of them make an *Ame* of the same Place. The *Metalis* of *Tripoly*, and every where else in *Barbary*, is 42 *Rotules*, and is equal to $7\frac{1}{2}$ *Ames* of *Antwerp*; from whence we may conclude, that each of them weighs 40 lb of *Liquor Antwerp Weight*.

ALMA is a *Measure* at *Constantinople*, which answers to $1\frac{1}{2}$ *Stope* of *Antwerp*; the *Liquor* contained in it weighs 10 lb of *Antwerp*.

DORACH or DORAG is a *Liquid Measure* amongst the *Arabians*; it approaches pretty near to the *Amphora Romana*, and is divided into 8 *Jobein*.

JOHEIN is divided into 6 *Kist* or *Afcats*, which nearly answer to the *Roman Congius*.

KIST or ASCAT into 2 *Corbins* or *Heminæ*, as the *Romans* had it.

CORBIN into 2 *Keliath*, which bear some Affinity to the *Roman Quartarii*.

KELIATH into 2 *Caffuk* or *Arfoes*, which equal the *Roman Acetabula*.

CAFFUK or ARSIVE into 2 *Cuatum*, or as the *Romans* had it *Cyathi* or *Cups*.

CUATUM into 4 *Salgerins*, which are perfectly the *Roman Cochlearii* or *Spoons*.

Jobein amongst the *Arabians* is what the *Congius* was amongst the *Romans*, and what the *Greeks* called *Hina*; it is $1\frac{1}{2}$ *Stope* of *Antwerp*, and consequently the *Dorach* is 12 of the same *Stopes*.

ARTABA is an *Egyptian Measure* which just answers to 18 *Stopes* of *Antwerp*.

COLLATHUM in the same Country is 6 *Antwerp Stopes* of *Liquor*.

SUBITHA is an *Egyptian Measure*, which is equal to $5\frac{1}{2}$ *Stopes* of the aforementioned Place.

DADIX is 4 *Stopes* of *Antwerp*.

COPHINUS is 3 of the same.

CHÆNIX of the *Egyptians* and the *Antwerpian Stope* are exactly the same.

The MARES and PONTES are but $\frac{1}{2}$ of the *Antwerp Stope*.

Dry Measure of the same People.

METRETES or METRETA is a *Measure* at this Day used all over Greece, it contains 12 Choas: 45 of these make a *Laste* in that Country; but the *Amsterdam Laste* requires 50 of the same.

The PERSIAN ARTABA or ATRABA is divided into 25 *Capile* or *Hemina*, or (if you will) *Hins*: 45 or 50 of these *Artaba* make an *Amsterdam Laste*. The *Egyptian Artaba* is divided into 5 *Aporrhimes* or *Aporrhime*, or into 40 *Chenices*, or into 480 *Inions* or *Inia*, or (if you will) *Sextaries*: 45 *Egyptian Artaba* are equal to an *Amsterdam Laste*.

TOPIN or TOPIUM in the same Country contains 10 *Chenices*; as does the *Epin* & *Sextaries* or *Inia*.

CAPHICI is a *Measure* in *Barbary* which ought to contain 20 *Guibes*: 7 of these *Caphici* are equal to an *Amsterdam Laste*.

DORACH or DORAG is the same *Arabian Measure* I just now mentioned. They divide it in the same manner both for *Liquid* and *Dry Things*: Thus 80 *Dorach* answer exactly to an *Amsterdam Laste*.

Thus have I done with what I propos'd to say concerning the *Measures* of Capacity; which if it falls short of the Reader's Expectation, I am very sorry for it; but upon the whole I conceive that this *Essay* will not be entirely undeserving of favour, if it be duly considered, that I have done my utmost in it; and that I have been induced to it by no other Motive, than an earnest Desire, of helping the *Pyrotechnician* and other *Mechanicks*, to attain such a Knowledge in this Matter, as is not to be acquired but by long Study, and continual Practice.

C H A P. XIII.

Of Long Measure, or the Mensuration of Space.

I Shall now proceed to instruct you in the nature of several sorts of *Measures*, which we shall often mention in the Sequel of this Work, when we speak of the Mensuration of Lines and Surfaces; so that a thorough Knowledge as to what concerns this sort of *Measure* will be absolutely necessary. We will begin with the least of them, and go on in the same Order and Method, as has always been observed by *Geometricians*, and shall call them by the very Names they have given them. And First;

A FINGER, as it is called by the *Germans*, *English*, *Dutch* and *Flemmings*; by the *Poles*, *Palec*; by the *Latins*, *Digitus*, and by the *Hebrews*, *Esath*, is 4 *Barley-corns* placed on one side each other: Now the

76 *Of the Great Art of ARTILLERY.*

the *Barley-corn* is subdivided into 5 *Poppy Seeds*, and this is the smallest *Measure* that can be assigned to *Distances*. But *Mersennus* contradicts this, and says, he found that the *Seed* of a *Red Poppy* is larger than that of the *White*: He farther says, that 2 *Grains* of *Mustard-Seed* touching one another, are equal to a *Line* of the *French Inch*; to which also 3 *Grains* of *Red Poppy Seed*, and 4 of *White*, are equal. He again tells us, that a *Grain* of *Scolopender* or *Finger-Fern Seed*, bears the same *Proportion* to a *Grain* of *Mustard-Seed*, as 1 does to 5. From whence we may allow, that a *Grain* of *Scolopender* is the least of all *Seeds*, since its *Diameter* is contained 2 $\frac{1}{2}$ *Times* in the *Diameter* of a *Grain* of *White Poppy Seed*. As for the smallest *Grains* of *Sand*, the same *Author* adds, that 12 of them placed in a *Right Line*, and touching one another, take up the *Space* of a *French Line* of an *Inch*. Let us hence conclude, that these *Grains* of *Sand*, in their utmost *Tenuity* or *Fineness*, are the smallest *Measure* we can think of.

The *UNICA, INCH, or DIGITUS MAJOR*, called by the *Germans*, *Zel* and *Daum*, contains in *Length* 4 *Barley-corns*, and is by the *French* divided into 12 *Parts* or *Lines*.

The *SMALL-PALM*, by the *Greeks*, *Doron*, and by the *Germans*, *ein Quere Handt*, and by the *Poles*, *Dlen*, ought to be 4 *Fingers* or *Digits* broad.

The *Length* of the *Hand* is what the *Greeks* called *Ortbodoron*, it is exactly 11 *Digits*.

The *GREAT-PALM, or SPITHAMA*, by the *Greeks*, *Lychas*, by the *Hebrews*, *Tophac*, by the *Germans*, *ein Spann*, by the *Poles*, *Piada*, and by us a *Span*, is 3 *small Palms*, or 12 *Digits*, or 9 *Unciæ* or *Inches*: This *Measure* (as *Mersennus* says) ought to be taken from the *Extremities* of the *Thumb* and *little Finger*, when stretched out to the utmost *Extent* they can be.

The *FOOT*, by the *Germans*, *ein Fufs*, or *Schuch*, and by the *Poles*, *Stopa*, ought to be 4 *Palms*, or 16 *Digits*, or 12 *Unciæ* or *Inches*. Concerning the *Division* of the *Foot*, *Philander*, one of the *Commentators* upon *Vitruvius*, has made the following *Remarks* upon his III^d *Chap.* and III^d *Book*, (*viz.*) *Columella*, *Frontinus*, *Isidorus*, and some others, differed from *Vitruvius* in the *Division* of the *Foot*; for all, except this *Author*, were for having it divided from the *Beginning* into 4 *Palms* or 16 *Digits*; but as this *Division* was somewhat perplexed and irregular, those who stuck to it, taking an *Assis* for a *Foot*, divided it as well as every *Integer* (which they commonly called *Assis*) into 12 equal *Parts*; one of which was called an *Unciæ*; two of them a *Sextans*; three a *Quadrans*; four a *Triens*; five a *Quincunx*; six a *Semis*, and so on to twelve, which constituted the *Assis* or *Foot*. But our *Geometricians* having considered, that the *Unciæ* answered to our *Inches*, rejected the former *Name*, and assumed the latter; and indeed if we compare them together, we shall find that 3 *Inches* make 4 *Fingers*. Observe here, that I do not speak with regard to the *Remark* in

Frontinus's

Of the Great Art of ARTILLERY. 77

Frontinus's Book of Aqueducts, where he mentions two sorts of the Inch, namely, the Round Inch and Square one, and that the Round Inch is less than the Square one, by three of its own Elevenths, and that the Square is bigger than the Round one, by three of its Fourteenths. This is Philander's Opinion concerning the Division of the Roman Foot.

What I have further to add, is that the Roman Foot is of various Length in different Parts of the World: In some Places it is of two sorts; as for Example, Swenterus relates, that there are two sorts of it in the Town of Noremberg (namely) the Town or Civil Foot, which they call *Stadt-Schuch*, which contains 12 *Uncie* or *Inches*; and the Mechanick or Work Foot, which they call *Werk-Schuch*, which is but 11 of the same *Inches*; but this Foot they have divided into 12 equal Parts, which they call *Uncie* or *Inches*, in Imitation of those of which the Town Foot is composed. Now perceiving that this great Inequality of Measure, would perplex and confuse us in a great many of our Operations; I had formed a Design of reducing the Feet of all the most famous Provinces and Cities in the World, to one that was determined, and the best known of all, and to compare them with that, in the same manner as has been done with regard to the Contents and Capacities of Weights and Measures. But Matthias Degen anticipated my Intention, by lately publishing a Treatise of *Military Architecture*; so that he has eased me of this Piece of Trouble, and got that Palm which I proposed to acquire as the Reward of such an Attempt; therefore finding that he has acquitted himself very handsomely upon this Head, and that he has reduced all the Feet to that of *Rhyland* or *Rynland*; I shall only transcribe them from him, for the use of the *Pyrotechnician* and others.

<p>If the <i>Rynland</i> or <i>Leyden</i> Foot was divided into 1000 equal Parts; the Foot of each of these Places would contain such a Number of those Parts as are expressed over against the Measure of each Place in this Table; (<i>viz.</i>) the Foot</p>	<table border="0" style="width: 100%; border-collapse: collapse;"> <tr><td style="padding: 2px;">Of Amsterdam</td><td style="text-align: right; padding: 2px;">968</td><td style="padding: 2px;">The Measure placed</td></tr> <tr><td style="padding: 2px;">Of Antwerp</td><td style="text-align: right; padding: 2px;">969</td><td style="padding: 2px;">before the Palace.</td></tr> <tr><td style="padding: 2px;">Of Alexandria</td><td style="text-align: right; padding: 2px;">1200</td><td></td></tr> <tr><td style="padding: 2px;">Of Antioch</td><td style="text-align: right; padding: 2px;">1260</td><td></td></tr> <tr><td style="padding: 2px;">Of Strasburgh</td><td style="text-align: right; padding: 2px;">891</td><td></td></tr> <tr><td style="padding: 2px;">Of Babylon</td><td style="text-align: right; padding: 2px;">1172</td><td></td></tr> <tr><td style="padding: 2px;">Of Bavaria</td><td style="text-align: right; padding: 2px;">924</td><td></td></tr> <tr><td style="padding: 2px;">Of Bremen</td><td style="text-align: right; padding: 2px;">934</td><td></td></tr> <tr><td style="padding: 2px;">Of the Brill</td><td style="text-align: right; padding: 2px;">1060</td><td></td></tr> <tr><td style="padding: 2px;">Of Dert</td><td style="text-align: right; padding: 2px;">1050</td><td></td></tr> <tr><td style="padding: 2px;">Of Goeffe</td><td style="text-align: right; padding: 2px;">954</td><td></td></tr> <tr><td style="padding: 2px;">Of Antient Greece</td><td style="text-align: right; padding: 2px;">1042</td><td></td></tr> <tr><td style="padding: 2px;">Of Copenhagen</td><td style="text-align: right; padding: 2px;">934</td><td></td></tr> <tr><td style="padding: 2px;">Of London</td><td style="text-align: right; padding: 2px;">968</td><td style="padding: 2px;">This is used all over</td></tr> <tr><td style="padding: 2px;">Of Livonia</td><td style="text-align: right; padding: 2px;">909</td><td style="padding: 2px;">England.</td></tr> <tr><td style="padding: 2px;">Of Malines</td><td style="text-align: right; padding: 2px;">890</td><td></td></tr> <tr><td style="padding: 2px;">Of Middleburgh</td><td style="text-align: right; padding: 2px;">960</td><td></td></tr> <tr><td style="padding: 2px;">Of Noremberg</td><td style="text-align: right; padding: 2px;">974</td><td></td></tr> <tr><td style="padding: 2px;">Of Paris</td><td style="text-align: right; padding: 2px;">1055</td><td style="padding: 2px;">The Royal Foot.</td></tr> <tr><td style="padding: 2px;">Of Antient Rome</td><td style="text-align: right; padding: 2px;">1000</td><td></td></tr> <tr><td style="padding: 2px;">Of Samos</td><td style="text-align: right; padding: 2px;">1200</td><td></td></tr> <tr><td style="padding: 2px;">Of Toledo</td><td style="text-align: right; padding: 2px;">867</td><td></td></tr> <tr><td style="padding: 2px;">Of Venice</td><td style="text-align: right; padding: 2px;">1120</td><td></td></tr> <tr><td style="padding: 2px;">Of Zurich</td><td style="text-align: right; padding: 2px;">988</td><td></td></tr> </table>	Of Amsterdam	968	The Measure placed	Of Antwerp	969	before the Palace.	Of Alexandria	1200		Of Antioch	1260		Of Strasburgh	891		Of Babylon	1172		Of Bavaria	924		Of Bremen	934		Of the Brill	1060		Of Dert	1050		Of Goeffe	954		Of Antient Greece	1042		Of Copenhagen	934		Of London	968	This is used all over	Of Livonia	909	England.	Of Malines	890		Of Middleburgh	960		Of Noremberg	974		Of Paris	1055	The Royal Foot.	Of Antient Rome	1000		Of Samos	1200		Of Toledo	867		Of Venice	1120		Of Zurich	988	
Of Amsterdam	968	The Measure placed																																																																							
Of Antwerp	969	before the Palace.																																																																							
Of Alexandria	1200																																																																								
Of Antioch	1260																																																																								
Of Strasburgh	891																																																																								
Of Babylon	1172																																																																								
Of Bavaria	924																																																																								
Of Bremen	934																																																																								
Of the Brill	1060																																																																								
Of Dert	1050																																																																								
Of Goeffe	954																																																																								
Of Antient Greece	1042																																																																								
Of Copenhagen	934																																																																								
Of London	968	This is used all over																																																																							
Of Livonia	909	England.																																																																							
Of Malines	890																																																																								
Of Middleburgh	960																																																																								
Of Noremberg	974																																																																								
Of Paris	1055	The Royal Foot.																																																																							
Of Antient Rome	1000																																																																								
Of Samos	1200																																																																								
Of Toledo	867																																																																								
Of Venice	1120																																																																								
Of Zurich	988																																																																								

78 *Of the Great Art of ARTILLERY.*

I shall to this add what has been remarked of the *Old Roman Foot*, namely, that it bears such Proportion to that of *Rynland* as 975 does to 1000. I mean that *Roman Foot*, the half of whose Dimensions we find in *Pbilander*, the Interpreter of, and Commentator upon, *Vitruvius*, in his Book III. Chap. III. which, he says, was taken from an Antique Marble, still to be seen at *Rome* in the Gardens of *Angelus Colotius*, and answers pretty well to that which was found on the Monument of *Cestucius Statilius*, which having been a little while ago discovered by *James Meleghini* (one of the best Architects belonging to the Pope) was through his Means removed to the *Vatican Garden*.

Moreover *Merfennus* observes in the Margin of his first Book of *Measures, &c.* that there are two different sorts of Measure of the *Old Roman Half-Foot*; one of which he says was taken from the old Walls of the *Capitol*, and is carefully preserved in the Library at *Paris*. This (as I have often tried) when doubled does not agree with the whole *Roman Foot* which *Pbilander* has given us, by nearly $\frac{1}{4}$, and is $\frac{1}{4}$, or $\frac{1}{1000}$ less than the *Rynland Foot*; and thus this Foot is to the *Rynland Foot* as 950 is to 1000. I have farther observed, that this Foot of the *Capitol* is exactly the same with that of *Poland* (of which I have a very nice Measure) which Foot is likewise used in *Lithuania*. We find another Measure of the Half Foot, which is taken notice of by *Merfennus*, and which *Villalpandus* says he took from *Congius Farnesianus*. The Measure of the *Roman Foot* which *Pbilander* has given us, exceeds the double of this last by $\frac{1}{1000}$, and its Proportion to the *Rynland Foot* is as 969 to 1000. *Merfennus* assures us again in the same Place, that the *Royal Foot of France* (the Measure of half of which he also gives us) exceeds the *Rynland Foot* by 6 Lines, or $\frac{1}{2}$ an Inch. But having myself applied the double of this Measure to the *Rynland Foot*, I found that the former exceeds the latter by $\frac{1}{1000}$; therefore according to my Observation the *French Foot* is to that of *Rynland*, as 1050 is to 1000. But we have said enough of the Foot, proceed we now to such Measures as are larger and more considerable.

The *PALMI-PES* of the *Latins*, and the *PENTADORON* and *PIGON* of the *Greeks*, which we will call the *PALM-FOOT* from the first of them, is a Measure that takes in the length of 20 *Fingers*, or *Digits*; that is a *Palm* and a *Foot*; and is to be taken from the Extremity of the *Elbow* to that of the *Hand* when closed, or the *Fist*.

The *ELL*, by the *Hebrews*, *Ammach*, by the *Germans*, *ein Elen*, or *Elbogen*, and by the *Poles*, *Lokiec*, is 24 *Fingers*, or 6 *Palms*, or 1 $\frac{1}{2}$ *Foot*, or 18 *Unciae*. This Measure is taken from the Extremity of the *Elbow* to that of the middle *Finger*. In *Perfa* and *Egypt*, the *Geometrical Ell* is 6 of ours. The *English Ell* is 3 *Feet*, 9 *Unciae* or *Inches*.

But there being so great a Variety in the Length of the *Ell* in different Places, as well as in that of the *Foot*; I here shall give you the Reduction of it to the *Rynland Foot*, as we have borrowed it from the abovementioned *Matthias Dogen*.

If

If the Rynland Foot was divided into 1000 equal Parts, the Ell of each of these Places would contain such a Number of those Parts, as is expressed over-against the Name of each Place in this Table, (*viz.*) the Ell

Of Amsterdam	2196
Of Antwerp	2210
Of Dantzick	1842
Of Hereford	1326
Of Florence	1846
Of Francfort upon Main	1760
Of Hamburgb	1842
Of Leyden	2187
Of Lubeck	1842
Of London	2904
Of Middleburgh	2105
Of Noremberg	2105
Of Oudewater	2190
Of Revel	1768
Of Riga	1768
Of Toledo	2500
The Vara of Lisbon	2662

To this I shall subjoin, from *Merfennus*, that the *Paris Ell* contains 3 *French Feet* and 7 $\frac{1}{2}$ *Inches*; consequently it will bear such Proportion to the *Rynland Foot* (according to our Observations) as 3806 and $\frac{2}{3}$ does to 1000. But, according to *Dogen*, it is as 3824 to 1000, or thereabouts. In *Poland* the *Ell* is 2 *Feet*, and this *Ell* (if our Observations are right) is to the *Rynland Foot* as 1900 is to 1000.

Besides this, *Merfennus* assures us, that the *Broccio* or *Brace* of *Florence* (which is a kind of *Ell*) bears such Proportion to the *French Foot* as 43 does to 24. But as to the *Hebrew Ell*, he makes it 1 *Foot*, 4 *Inches*, and 3 *Lines*, according to the *Capitoline Measure* before-mention'd.

The *PACE*, which the *Latins* called *Gradus*, *Gressus*, or *Passus Simplex*, the *Germans* *ein Einfacher Schrit*, the *Dutch* *een Stap* or *Trede*, and the *Poles* *Krok*, ought to be 2 $\frac{1}{2}$ *Feet* long.

The *PACE*, which the *Germans* understand by the Words *ein Doppelter Schrit*, is exactly 5 *Feet*.

The *ORGYA* or *FATHOM*, which the *Germans* call *ein Klafter*, the *People* of the *Low Countries* *een Vademe*, and the *Poles* *Zazen*, ought to be 6 *Feet* long. *Julian* the *Afcolomite*, an excellent *Architect*, would have this Measure called an *Ell*.

The *CANNA* and *REED*, which the *Hebrews* called *Kennech*, is 6 of the *Hebrew Ells*. *Merfennus* maintains that this Measure contains 8 *Feet* and 1 $\frac{1}{2}$ *Inch*, according to the *Ratio* between the *Capitoline Foot* and that of *France*, which (as he says) is as 130 is to 144, or as 65 is to 72, or thereabouts.

The *PERCH* or *RODD*, of 10 *Feet*, which, amongst the *Germans*, is called *ein Mess-rubte*, or *Stange*, by the *Flemmings* *een Roede*, and by the *Poles* *Prent*, was formerly divided into 10 *Feet* by the Ancient

80 *Of the Great Art of ARTILLERY.*

cient *Romans*; from whence they gave it the Name of *Decempeda*; upon which Account it was that *Cicero*, that Prince of Orators who knew so well how to adapt significant Terms upon all Occasions, called those *Geometricians* of his time that used this Measure *Decempedatores*. Its Length is varied infinitely at present: As for Example; in the *Low Countries* the *Rhylandic Perch* is 12 *Rhyland Feet*; but to render the Calculation of this Measure easy, and as much as possible to avoid Fractions, their *Geometricians* have divided it into 10 equal parts, which they call *Feet*, each of which are subdivided into 10 *Unciæ*. In *Poland* and *Prussia* the *Perch* is 15 *Feet*, or $7\frac{1}{2}$ of their *Ells*; this is what they call *Culmenic*, but commonly *Prent*, or *Miara Chelmienska*. In the Territory of *Noremburg* it is 16 *Feet*. In the Marquisate of *Brandenburg* 12 *Feet*. In *France* (according to *Mersennus*) 22 *Feet* make a *Perch*. In the Territory of *Ghent* 14 *Feet*, but every where else in *Flanders* it is 20 *Feet*. There likewise does the *Foot* vary, inasmuch as in some Places it is 10, and in others but 11 *Unciæ*. In *England* the *Perch* is $16\frac{1}{2}$ *Feet*, and in *Ireland* 18.

The **CORD or CHAIN** is a kind of Measure well known in most Countries, and is what the *Latins* called *Funis Chorda* and *Catena*; the *Germans* call it *ein Schnur* and *Kette*: This is what the *Romans* formerly meant by the *Arvipendium*; the *Poles* call it *Sznur* and *Weijfsko*, with whom it is 10 *Perches*: But its Length is not always the same amongst Surveyors.

The **STADIUM or FURLONG**, and the *Aule*, *Rosse-lauff* of the *Germans*, and *Stoia* of the *Poles*, is in Length 125 *Geometrical Paces*, or 625 *Feet*: Among the *Greeks* the *Stadium* was 125 *Paces*, and was properly the Measure of a *Foot Race*.

The **DIAULUS** was double of the *Stadium*, it being 250 *Paces*.

The **HIPPICUM** was 4 *Stadia* or 500 *Paces*: This was properly the Measure of an *Horse Race*, or *Breathing*.

The **DOLICHUS** was 12 *Stadia*.

The **SCHÆNOS** was 60 *Stadia*; but in some Places 40, and in others but 20 only.

The **MILE** is a Measure well known to all the *Europeans*, and is derived from the *Latin Word Mille* a Thousand, the *Roman Mile* being always composed of 1000 *Paces*: But this Measure varying its Dimensions in the different Places where it is used, I have here inserted a Collection of such *Spaces*, as are the most common in several Countries, and which bear any Affinity to the Mile; that you may with the more Ease and Exactness compare the Mile of one Country with that of another; and that you may see the different Measures with which *Geographers* determine the Distance of Places: These are reduced to the *Rhyland Foot*; (which we here own to be equal to the *Roman*) the whole according to the Calculation of *Doyen*.

Of the Great Art of ARTILLERY. 81

MILES.	FEET.	
Of <i>Ægypt</i> . - - -	25,000 called <i>Schænos</i> .	
Of <i>England</i> . - - -	5,454	
Of <i>Burgundy</i> . - - -	18,000	
Of <i>Flanders</i> . - - -	20,000	
Of <i>France</i> . - - -	15,750 called <i>Lieüe</i> or <i>League</i> .	
Of <i>Germany</i> . - - -	}	20,000 the <i>Lesser</i> .
		22,500 the <i>Mean</i> .
		25,000 the <i>Greater</i> .
Of <i>Holland</i> . - - -	24,000	
Of <i>Switzerland</i> . - - -	26,666	
Of <i>Spain</i> . - - -	21,270 called <i>Legua</i> .	
Of the <i>Hirarian Way</i> .	15,000	
Of <i>Italy</i> . - - -	5,000	
Of <i>Lithuania</i> . - - -	28,500 called <i>Mila</i> .	
Of <i>Moscovy</i> . - - -	3,750 called <i>Warsta</i> .	
Of <i>Poland</i> . - - -	19,850 called also <i>Mila</i> .	
Of <i>Persia</i> . - - -	18,750 called <i>Parasfang</i> .	
Of <i>Scotland</i> . - - -	6,000	
Of <i>Sweden</i> . - - -	30,000	

I shall now hasten to a Conclusion of this Book, omitting several other kinds of *Measure* used in surveying Land, in which the Surveyors are governed by the Custom of the Country where they are employed, and which the *Pyrotechnician* has nothing to do with. I shall only add that the *Polish Acre* (which the *Poles* call *Lan Role*, the *Germans*, *Morgen* and *Jauchart*, and the *Flemmings*, *een Bunder-Landts*) is the Breadth of one of their *Chains*, or 10 *Perches* of 15 *Feet* each, or 150 *Feet*; its Length is thrice its Breadth, or 3 *Chains*, or 30 *Perches*, which are 450 *Feet*. Moreover this same *Acre* contains 67500 *Square Feet*. From whence it appears, that the *Polish Acre* is bigger than the *Old Roman one*, which they called a double Square or *Actus*, which was but 120 *Feet* Broad and 240 in Length, and consequently contained but 2880 *Square Feet*. The *Old Roman* and *Polish Feet* are equal, as I have already shewn.

Again; let us add that 30 *Square Acres* of *Lithuania* and *Warsovia*, constitute a certain Measure or Portion of Ground which the *Latins* called *Manſio* and *Modus Agri*, that is, a Day's Journey, and Form of a Field; and which is commonly called by the People of those Countries *Wloka*, and is the same that the *Germans* mean by *Hube* or *Hufe*. Now the Breadth of this Plot of Ground is always 4500 *Feet*, or 30 *Chains*, or 300 *Polish Perches*, and its Length is the Length of 3 *Chains* or 30 *Perches*, or 450 *Feet*; and the whole *Area* of it contains 2025000 *Square Feet*.

Y

Again;

82 *Of the Great Art of ARTILLERY.*

Again; in *Warsovia* they divide the Breadth of the *Acre* into 2 *Zagon Liras* (as they call them) each of which is 75 *Feet* Broad. Those who would know more of this may consult the Surveyors of Land, and such *Geometricians* as have more to do with it than I.

To conclude: You will have the true and exact *Measure* of the *Rhynland Foot*, as well as of all those reduced to it, in our universal *Pyrotechnical Instrument*, the Form and Use of which I shall give in the second Part of our *Artillery*. Proceed we now from the *Theory* to the *Practice* of our *Pyrotechnics*, and set ourselves to work, since this Book has so plentifully furnished us with the necessary *Tools*. Attend then to what follows.





OF THE
 GREAT ART
 OF
 ARTILLERY.

PART *the* FIRST.

B O O K II.

*Concerning the Things which are commonly used
 in Pyrotechnics, or Artificial Fireworks.*

C H A P. I.

Of the Origin of Saltpeter: its Nature and Operations.



IT is most certain that several learned Persons, and such as were versed in *Natural Philosophy* in the early Ages of the World, were well acquainted with the Nature of Saltpeter and Salnitre. For a Proof of this we need only consult the Sacred Writers, by whom we shall find it particularly mentioned, as may be seen in the * Fifth Book of *Moses*, Chap. xxix. We shall likewise find it largely treated of by several Prophan Authors, of which Number is *Pliny*, who says a great many Things of it,
Lib.

* Deuteronomy xxix. ver. 23. *And that the whole land thereof is Brimstone and Salt and Burning, and that it is not sown, nor beareth, nor any grass groweth therein, like the over-brow of Sodom and Gemorrah, Admah and Zeboim, which the Lord overthrew in his Anger and in his Wrath.*

Lib. xxxi. Cap. vii. and x. as does likewise *Vitruvius*, Lib. vii. Cap. xi. *Aristotle*, *Seneca*, and *Dioscorides* Lib. v. Cap. cxxii. *Philostratus* in the Life of *Apollonius Tyaneus*; together with a prodigious Number of others too tedious to enumerate, from whom the Truth of this Assertion may be proved, namely, that the Ancients were acquainted with the Properties of Saltpeter. What I have to say upon this Head is, that there are some Moderns who are firmly of opinion, that the Saltpeter used by the *Pyrotechnicians* in our Days, is widely different in Form and Virtue from the Nitre of the Ancients, and consequently will have it, that ours is a new Invention, or a Discovery of very late Date, purely calculated for the Service of Cannon. Those who entertain this Opinion are thus far supported by Reason; that we are assured by several That the Ancients knew of but one kind of Nitre, (*viz.*) the Mineral or Fossil sort, which was naturally formed without any human Art, in Places from whence they took it: And this they divided into four different sorts, namely, the *Armenian*, the *African* (from whence the Afro-nitre which *Avicenna* calls *Baurach* in *Arabick*) the *Roman*, and the *Egyptian*; and was called Nitre from a certain Region in *Egypt*, where it was found in great abundance. *Serapion* moreover relates that the Mines which produced Nitre, were perfectly like those of common Salt, in which running Water is congealed and condensed, and that it was no more nor less than a meer Stone, from whence it got the Name of Saltpeter or Stone Salt. He adds again, that Nitre was of several Colours, as white, red, ruddy, livid, or lead Colour, and of every other Tincture it was capable of: Furthermore, the Construction or Form of it was various; for some of it was porous and spongey; and some of it on the contrary, was more closely compacted, solid, bright, transparent, brittle, glittering with small Sparkles, and crumbled with handling. From these Accidents they judged of its Virtue and natural Force, the one being much more powerful than the other in its Operations. This is what I have been able to collect, from the Testimony of the best received Authors, concerning the Mineral Nitre; amongst whom I do not find the least mention made of the Artificial Nitre now used by us, and which we properly call Saltpeter, Salnitre, or Halinitre. But whether this Ancient Nitre is entirely lost to us (which however *Scaliger* denies, *Exoter* in a Dispute with *Cardan* concerning *Subtily*, Lib. xv. *Exercit.* 104. 15. besides its being commonly sold in *Asia* and in *Egypt*, and according to *John Pardo* in a small Town in the *Hertrurian* Field, called the Valley of *Elsa*, where it is found in great Plenty) or whether it does not reach us, it is difficult to pass any certain Judgment concerning it, or to distinguish between the one and the other, I mean between the Old and the New, though you should compare the Virtue and Qualities of the one with the Effects of the other. Nevertheless the learned *Scaliger* strenuously maintains, in the Place I have already quoted, that this Ancient Nitre (if any of it is remaining) is not very different

different from our Saltpeter, particularly if we consider it as to the Fineness of its Parts which are very subtile and aerial. I shall here insert the following Words from him, because they will not a little contribute to the Proof of this Matter. *For as some Salt is Fossil, some extracted from Sea Water, some from Springs, and some from Ashes; or as Glass is produced from Stone or Flint, so likewise may a Salt be naturally generated from Nitre; and accordingly it springs out in Caverns, as we are told by Pliny. That which shoots out of the Surface is commonly concreted in the Form of Salt by the Heat of the Sun. But Saltpeter is so far from being a Fossil Salt, as its parts are more subtile, than the parts of either that or Nitre; for both Salt and Nitre are not so universally consumed by Fire, but that some Dregs remain after their Combustion; but Saltpeter is entirely absorbed by it. Wherefore the Fossil Salt is more terrestrious or earthy than the Nitre of the † Nitraria, and this Nitre than that which springs out in Caverns. This Cavernous Salt is like a very fine Flower: But on the contrary must not this be more earthy than that, because it is less aerial? And that more aerial than this, because it is more refined in the Nitraria than in Caverns? The finest Particles of that which shoots out of the Surface are exhaled by the Sun; but in Caverns it is quite otherwise. Must not therefore the Cavernous Salt be more crass or gross, because it is less refined? Just as green Fruits are more crude, than those that are ripened, and have imbibed the Sun-beams. The Fossil is more gross than the Sea Salt, as well on account of its Coëtion or Preparation, as of its Substance. This is too Aqueous, and that is too Terrestrious; and neither of them so subtile as Saltpeter. There is a Moisture that is in some degree natural to Nitre; but as it is a kind of subtile Scum, it is entirely devoured by Fire. And even as that Camphire which bursts through the Rind or Bark of the Tree is preferable to that which is untimely taken out of the Matrix where it is formed; so that Nitre which springs out of the Surface is the best: That indeed which is generated in Furrows in the Clefts of Caverns is finer, if we consider it purely as to its Parts; but if you will make an Allowance for the Operation of the Sun-beams it must be less pure. That which adheres to Rocks where it is dried up, (from whence it is called Saltpeter,) bears a great Analogy and Likeness in Nature to Nitre itself, but it is more Aerial, and rather inclining to the old kind of Afronitre; for we have frequently observed a kind of Lustre of a glimmering Purple in the Shivers of Saltpeter.*

Thus by the Arguments of this great Man we see, that there is as much difference between Nitre and Saltpeter, as there is between a perfect and an imperfect Mineral; between one that is pure and refined, and one that is rude and gross; between what is subtile and aerial, and what is earthy and crass; in short, as much as is between a Spirit and a Body. We may then conclude that Saltpeter is the noblest kind of Nitre. That the sort in use with us, was not well known to the Ancients we shall

Z

call

† By *Nitraria* you are to understand a Place where Nitre is refined or perfected either by the Sun or by Fire.

call *Pliny* to witness, not to mention several others who would do the same: For he openly and plainly calls that Salt which was naturally formed, on the Surface of Rocks, and in Caverns and deep Cavities of the Earth, the *Flower* and *Scum* of Nitre, and Saltpeter or Stone Salt: A little of this is still found in some Places, and in others none at all: It is generally met with upon old Walls and Ruins which are exposed to the Wet; but particularly in Cellars and Vaults, where Wine is kept, and in many other subterraneous Places which are cool and damp: It nearly resembles white Frost, or pure Flower, or fine Sugar, and is as white as Snow: The Virtue of this is very considerable, as I myself have sometimes experimented. If you would prepare this Salt by the Rules of our Art, it must be granulated into small Corns, and you will see how exactly it will assume the Form of the ancient Nitre which *Pliny* speaks of, and which *Scaliger* describes above. But as it has been impossible to get sufficient Quantities of this, to answer the continual Demand there has been of it, for the Service of so many Wars, which have been in Agitation for so long a time past; and preyed upon the finest Inheritances of Princes, and wasted before our Eyes, the greatest part of the most powerful Empires, and most noble States of the Universe; Men have been obliged to seek out a new sort, to supply the Defect of the Old; which being with much Labour and Industry taken from the Bowels of the Earth, it is purified, and washed several times, in order to separate all terrestrious and gross Particles from it, and to divest it of its native Crudity. In short, it is cleaned, and brought to such a Degree of Perfection, that it yields neither in Form nor Virtue to the Saltpeter of *Pliny*, nor even to that of *Scaliger*.

Therefore if I may have leave to declare my Sentiment as to this Point, I shall (to remove all manner of doubt) insist upon it, that *Scaliger* meant no other Saltpeter, or Salt condensed into a stony Consistence, than that whose Use, artificial Preparation, Origin, &c. is familiarly known to us, and which we shall sufficiently treat of in some of the Chapters of this Book. It is not a sufficient Objection against us to say, that our Salt does not grow naturally and of its own accord, like that of *Pliny* which springs out of the Surface of Rocks, and fills up the Clefs of Caverns, and the Apertures and Crevises of old Buildings, where it is condensed, concreted, or petrified in little Furrows; for as Art is the very Ape of Nature, and since she imitates her in every thing she is capable of; it must not be thought strange if we with a little of her Assistance, and a large Portion of our own Industry, attain to the Perfection of her Productions, and (if I may so say) exceed by far her most perfect and elaborate Works. Do we not see a vast Number of Masterly Performances exhibited by excellent Artists, after a long and assiduous Labour, which cannot possibly be imitated by Nature, though she were to exert her Power to the utmost? We may then conclude that our *Pyrotechnic Salt*, which bears down all before it, and forces its way every where, is very like the

Salt-

Saltpeter of the *Ancients*, or in a Word, that they do not in the least differ from one another. For if so it be, that the Nitre of the *Ancients* was or is a Fossil, I am inclined to think it was much of the same Nature with the Matter or Earth from whence we extract our *Saltpeter*; which if it be prepared according to our following Method, I may venture to affirm, that it will in every respect correspond with the natural *Saltpeter*, and by repeated Purgations, may become more pure and exquisite. In rectifying common Salt, and refining of Sugar, they are always finest after the last Operation. But notwithstanding what I have been saying I shall prove by a plain Argument, that the Opinion of those who believe our *Pyrotechnic Salt* to have been newly invented, is not only absurd but false likewise; inasmuch as several creditable Authors so highly and often commend the Inventor of *Gun-powder*; but sometimes speaking of him in another Strain they load him with a thousand Maledictions, and detest his pernicious and abominable Invention: It is not that they accuse him of having discovered a kind of *Saltpeter* till then unknown, for the Ruin and Extirpation of Mankind; but of having hit upon a Composition of certain Quantities of Nitre, (which was then commonly known) Sulphur and Charcoal mixed together, and of having introduced those thundering Engines of War, which they called *Cannons*, and what is worse, of having handed this destructive Invention down to Posterity. I however agree and believe, that *Saltpeter* was never used in the Composition of Artificial *Fire-works*, before our *Gun-powder* was found out; but in process of time, and as our Days increase in Experience, as well as in Number, People with Astonishment observed the strange Properties and horrible Effects of *Gun-powder* (of which *Saltpeter* may be properly called the very Soul) and perceiving that Fire dissipated and consumed it so universally, and seemed to devour it with more Greediness than any other Matter whatsoever, they took it into their Heads, to use it in making Artificial *Fire-works*, and so have continued to do to this Day. That which *Nicetas Choniates*, and *Johannes Zonaras* relate concerning the *Grecian Fire* which was invented before the Reign of *Constantine Pogonatos* Emperour of *Greece*, is not very repugnant to our Opinion: But there are those who assure us (though they are not much credited) that *Marcus Gracchus* was the Author of it, and to whom they attribute two sorts of it, which we shall speak of in another place, just as we find them taken Notice of in some *Arabic* Books, which are the same with those mentioned by *Scaliger* in his *Exercit. CXXXIII. Lib. XV.* against *Cardan*; in which I observe, that amongst the many combustible Matters they are composed of, *Saltpeter* and Oil of Nitre are not moderately used, but in Proportion to the rest make up the greatest part. This I think we may safely say, namely, that the mixing of *Saltpeter* with other combustible Ingredients is a new Invention; or else (as it may be too rash to doubt of what has been said by so many Authors of such great Probity, and who lived in so great Repu-

Reputation) we may conclude that it was not commonly known, and that it was concealed as an extraordinary *Secret*; which obliged *Semi-maurus* (as *Scaliger* has it) to say, that it was perfectly miraculous, because of its strange and wonderful Effects. I dare not doubt but that the Ancients had their Judgment so far enlightened as to know that Salnitre or Saltpeter was of a very igneous Nature; for it is a very old Opinion (though to some it may appear new) that though Saltpeter feels cold to the Touch, and appears white to the Eye, yet that it is very full of Red Spirits, and is naturally very hot and fiery. If we wanted Testimony to prove this, the *Holy Scripture*, which is the pure Fountain of Truth, will furnish us with it, by speaking so plainly of Fiery or Combustible Salt, in the Passage we have already quoted. But what surprizes me the most is, that the old *Romans* (not to mention the *Grecians* and *Carthaginians*, who at all Times, and in all Things were their great Emulators) who were the most perfect and best versed in Military Knowledge, of all the Nations which bore Arms in their Days; I say, it is surprizing to me, that though in their Defences and Attacks of so many considerable Places, that either owned their Power, or were besieged by them, they made great use of *Fireworks*, or burning Oil (which they called *Naptba*) Sulphur, Bitumen, Pitch, Frankincense, several Ways prepared, Rosin, &c. yet never made any Account of Saltpeter, whose Power and Efficacy far exceeds all those Things; whether it was that they preferred all those Drugs to it, or that their Engineers (which I dare not advance without trembling, since *Lipsius* says, *pauca non habemus inventa ab ævo illo meliore & sapientiore*) were Strangers to the Nature and Properties of it, and consequently were not aware of the Service it might be of in their *Fireworks*. However, it may not be unlikely that they used it, though they might keep it as a great and mysterious Secret in their *Pyrotechnicks*, and never divulged it to those whose Curiosity might lead them to inquire into the Cause of such wonderful Effects as they saw or heard of. Thus as it was only known to those who were immediately concerned in the Preparation of their *Fireworks*, neither *Titus Livy*, *Cæsar*, *Tacitus*, *Sallust*, *Polybius*, *Vegetius*, nor any other Historians, speak one Word of Salnitre, Nitre, or Saltpeter, in their Writings; though, amongst the famous and great Exploits of the *Romans*, they have described their Machines, their Arms, and their *Fireworks*. It is certain that both *Greeks* and *Romans*, *Arabians* and *Egyptians*, used Nitre in several of their Medicinal Compositions, if we may believe *Galen*, *Hippocrates*, *Theophrastus*, *Avicen*, *Averroes*, and the Writings of many other Authors. It has likewise been remarked in some Writers, that *Patrobius* a Freed-man of *Nero* sent to *Egypt* for certain fine Sands, found near the *Nile*, which were impregnated with a great deal of Nitre, with which he used to whiten his Skin; and I believe it was something like what *Ovid* speaks of in a Distich, by way of Advice to those of his Time who painted.

Nec

*Nec Cerussa tibi, nec Nitri spuma rubentis
Defit & Illirica quæ venit Iris humo.*

He here advises them not to be sparing of Ceruse and Nitre, &c.

And again,

*Thus ubi miscueris radenti tubera Nitro;
Ponderibus justis fac sic utrumque trahent.*

This was perhaps a kind of corrosive Composition made of equal Quantities of Nitre and Frankincense mixed together, which he prescribes for removing all Cutaneous Blemishes, such as Marks of the Small Pox, Pimples, Freckles, &c.

* The *Egyptians* seasoned their Horse-radish with Nitre, just as we do our common Radishes with Salt. The *Macedonians* mixed the Flower, with which they made Bread, with a little of the *Calistrine* Nitre, which was found in great quantities in the Quarries of *Clytes* in *Macedonia*; which was excellent Seasoning, and with which they salted their Meat. I believe I need say no more to you upon this Head, and that what I have offered here, will change the Opinion you might have had concerning Saltpeter, if you before entertained any Thoughts about it that were repugnant to ours; and I hope we shall for the future be of one Mind with regard to this Fact, jointly confessing that our *Pyrotechnic Salt* was very well known to the Ancients, and that it is very like their Nitre, before its being prepared; but being refined and purified, it exactly answers to their Saltpeter. This being laid down, let us proceed to the Artificial Preparation of our Salt. But in the mean time, I presume, it will not be taken amiss, that I close this Chapter with an Account of the Cause why Saltpeter detonates or makes a Noise and Sparkling in the Fire, by way of Corollary from *Scaliger* against *Cardan Lib. xv. Exercit. 24.* as follows: *Dii benefaciunt Salipetra, &c. May the Gods bless our Saltpeter* (cries he) *which keeps from us thy dangerous and fiery Difficulties, though of itself it be of the most igneous Nature. Thou wouldst have us believe that Saltpeter retains many earthy Particles, because it detonates, or makes a Noise in the Fire: But that can never be the Reason, for if it was, Earth ought to detonate when heated by that Element; which it does not. Is it then the Rarity of it? which Aristotle calls χαυώρητα and σμφορήτα; this I cannot think; for daily Experience shows us, that Mushrooms are silent on the Fire. Is it then the Hardness or Solidity of its Parts joined to its Rarity? This is not likely, since the Pumice-stone has not that noisy Quality. Some other thing must then be the cause of the Detonation of Saltpeter when enkindled. The Divine Preceptor in the eleventh Section of his Questions, says, That Salt-*

*pete*r makes a noise in the Fire, because it contains a great deal of Moisture in it, which being highly rarified by Heat becomes meerly spirituous: It is thus I interpret *ανδραματι*). It contains rather Air than Water, which being violently expanded by Fire, becomes impatient of the narrow Bounds which confined it, when cobering in a more compacted Form; and therefore bursts open its Prison; so that the outward Air being greatly agitated by this Explosion, you consequently hear that Clamour which usually attends the burning of Saltpeter, and other Things wherewith it is incorporated. Let not this appear strange; for Chestnuts, and Bay-leaves, as well as those of Juniper (and I believe the Berries of them too) do the same thing, which contain much Air and little Moisture. It is not so with the Pumice-stone, whose Pores are all open and pervious, and consequently the Air in them must be of the same Tenor with the circumambient Air.

C H A P. II.

The Method of preparing Saltpeter from a Salnitrous Earth.

THE Earth or Matter that is productive of *Saltpeter*, is commonly found in great Plenty, in dark, shady, and cavernous Places, which are equally guarded from the Heat of the Sun-beams, and from the Access of Rain, or any kind of fresh Water. It is likewise met with in Stables and other covered Enclosures where any sort of Cattle are kept; and also in such Places where Men usually discharge their Urine. In short, it is to be found in Fields and other Scenes of Battle, where Heaps of putrified Carcasses lay covered with Earth: Such Places as these have for many Years past been ransacked, where great Quantities of Salpetrous Matter have been found, particularly in *Wallackia*, and in the *Desarts* of *Podolia*, between the *Bob* and *Boristhenes*: Upon which Account the *Poles* have been formerly obliged to war against the *Grim* and *Precopian Tartars*, and what is worse are at this Day involved in dreadful Confusions with the *Cossacks*, who have rebelled against them. ‘ But, O God! be thou propitious to the Enterprizes of
 ‘ our invincible *John Casimir*, by thy infinite Goodness King of *Poland*
 ‘ and *Sweden*; inspire him, and conduct him in all his Undertakings, to
 ‘ the end that taking into his Hands the Reins of his Empire, which thou
 ‘ hast lately committed to him, he may not be inclined to guide them
 ‘ through the Paths of Clemency and Mercy; (Ornaments much more
 ‘ becoming a King, than the Severity of Punishments;) but may his aveng-
 ‘ ing and victorious Arms justly chastise the Insolence, and mow down
 ‘ the Heads of those turbulent Spirits, who though always born to Servitude,

' tude, yet like wild and restif Affes, have always resisted against the
 ' Spur, and formerly refused a Submission to the mildest Laws of their
 ' Sovereigns; and now not contented with a Prospect of Liberty (a Hap-
 ' piness too refined for their rude and barbarous Taste) they meditate I
 ' know not what Empire over others. May he extirpate the Generation
 ' of them, and when his just Severity shall have subdued them, may he
 ' deprive them of all Hopes of Forgiveness, and make them dearly pay
 ' for their perfidious Rebellion: In short, after having heaped dead Car-
 ' kass upon dead Carcass, and made dismal Burial-Places of that vile Race,
 ' (obliging them at once to groan under the Yoke of their own Ruin, and
 ' the Weight of our Earth, after the manner of the Giants whom *Jupiter*
 ' overwhelmed for a Crime of the like Nature) may we add the Hills of
 ' these newly-destroyed Carcasses to the old ones, whose faithless Foot-
 ' steps they pursued. From these Monuments of Mortality and just Ven-
 ' geance will Posterity have ample and glorious Subject, whereon to
 ' yield immortal Thanks to the Heroic Virtues of so powerful a King,
 ' when they shall with Astonishment behold the Trophies of so compleat
 ' a Victory, infinitely surpassing those famous Pyramids erected of old by
 ' the Vanity of *Memphis*, and which passed for Wonders amongst the An-
 ' cients. From hence likewise, from the Putrefaction of these Rebels,
 ' may be extracted *Saltpeter*, wherewith to make thunder-imitating
 ' Gun-powder, the Stench of whose Smoke shall have the same Effect
 ' upon the Remains of that ungovernable Race, if ever they revive such
 ' fatal Commotions, as the offensive *Effluvia* of the burnt Body of one
 ' Bug have upon its Survivors, which, according to *Naturalists*, destroy
 ' or deprive them of their noxious Qualities; like these therefore shall
 ' they all be destroyed, or being disarmed of their inveterate Untractable-
 ' ness, be obliged to live peaceably under the Yoke of the Prince, whom
 ' Heaven shall set over them; or else taking a distant Flight with such as
 ' are Enemies to their Country's Quiet, and dreading the Punishments
 ' they may justly expect; lose all Inclination, and never once entertain
 ' the least Desire of returning home again. ' These are the Vows, and
 this is the Prayer, which the Fidelity I bear to my Prince, and the
 Love I have for my Country, have dictated to my Pen; and which I
 hope the great Lord of Hosts will bring to pass, if he sees it will
 contribute to the Glory of his Holy Name. But I forget how insensi-
 bly I stray from my Subject; let us therefore resume it, and consider a
 little on the Methods of trying the Goodness of *Salnitrous Earth*.

There are three ways of doing it, from which you may determine
 with a good deal of Certainty, with regard to the Soil from whence
 you would extract *Saltpeter*; and which are the most practised by Per-
 sons concerned in this sort of Work.

The First as follows: Take a little of the Earth, which you ima-
 gine to be productive of *Saltpeter*, and put it upon your Tongue; if
 it

it bites a little sharply, it is a Sign your Labour will not be in vain; but if on the contrary it is flat and a little corrosive, I would not advise you to throw away your Time and Money about it.

The Second, is by making an Hole in the Earth, and throwing into it a Piece of red-hot Iron; which done, you must stop the Hole close up, 'till the Iron is cold; and if upon taking it out again you find any Spots or Marks about it of a Lemon or whitish-yellow Colour, you need not doubt of the Goodness of it.

Thirdly, You may make the Experiment by throwing a little of the Earth upon burning Coals, which if it makes a noise or crackling and emits bright Sparkles, you may depend upon it, that it will answer your Purpose.

Having by one, or all these Tryals, been convinced of the Goodness of the Soil, whence you propose to extract your *Saltpeter*, dig up what Quantity you want, and let it at once be carried to some convenient Place. Then get a good store of Wood, such as Oak, Ash, Elm, Maple, or any other hard kind of Wood, which you must burn, and preserve the Ashes. Then take two Parts of these Ashes, and three of Quick Lime, and incorporate them well together, and set this Mixture aside for the Use I shall hereafter mention. In the mean time get a large Tub or any wooden Vessel wide at top; and in the Bottom of it bore an Hole of an Inch or two Diameter; let this Hole be covered with small Twigs wrought in fashion of a little Hurdle, and then strew the Bottom of the Vessel all over with clean and whole Straw, not excepting the little Hole. This Vessel being prepared after this manner, place it so that a small Vessel may stand under it, to receive the Liquor which shall run from the upper one. Then begin with putting a *Stratum* or Layer of your Saltpetrous Earth in the Bottom of your Vessel, to the Height of a Palm, or the Thickness of 3 or 4 Inches, which before you do this, must be dried a little in the Air: Then upon this Earth put a Layer of 3 or 4 Inches deep of your Composition of wood Ashes and Quick Lime; and upon that, another Layer of your Earth, of the same Thickness with the former, and upon that again another Layer of your Composition; and so on alternately a Layer of Composition upon a Layer of Earth, and a Layer of Earth upon a Layer of Composition, *Stratum super Stratum*, till you are come within 3 or 4 Inches of the Brim of your Vessel, which Space you must leave for the Water which is to be poured upon it. This done, pour as much fresh Water upon it as you think needful; or to the Height of 3 or 4 Inches above your Ingredients; which as it penetrates and passes through the Mass of the Matter, contained in the Vessel, will distil Drop by Drop through the Hole in the Bottom of it, into the Recipient that stands under it, and you will have a *Salnitrous Lixivium* or Lye, in proportion to the Quantity of Water you shall have poured upon your Ingredients: If
you

you think it too little, you must repeat the Operation, so that the Water passing through them a second time, you may have the more of the *Salnitrous Particles* which the Water will bring away with it.

This being done, pour out the Lye in your Recipient into some Pot or Boiler of sufficient Capacity, and make it boil at first over a slow Fire, and after that over a strong one till a third of it is evaporated or wasted; then pour in again as much of the same Lye as will fill up the Boiler, and let it evaporate as before, and so continue to do till all your Lye has undergone this Ebullition. You must take care to scum the Lye whilst it is boiling with an Iron or Copper Scummer full of Holes. In short, the Lye being thus boiled, scummed, and cleansed from all its Filth, you may take it from off the Fire, and pour it into some Wooden Vessel; then covering it up close, let it stand till it is cold and settled, so that all the gross and earthy Particles in it may subside to the bottom.

After this, take the Vessel, and, by Inclination, pour out the clear Liquor only into a Boiler, as you did before, taking great Care that none of the Sediment runs in with it; and put it again upon a hot Fire, and let it boil till it is half evaporated, or till it begins to thicken, or till putting some Drops of it upon a Piece of rough Marble, or an Iron Plate, it is perceived to coagulate or chrystalize.

Then taking it from the Fire, let it cool a little, and pour it into Wooden Vessels that are broad and shallow, to the height of 2 or 3 Inches only, or thereabouts. After having covered these Coolers with Canvas, or coarse Cloth, let them be carried into some shady retired Place, where, after 3 or 4 Days, you will find the *Saltpeter* concreted in little Furrows, like Chrystal, sticking to the sides of the Vessels, or to little Sticks with the Bark stript off of them, and indifferently put into the Coolers before the Liquor was poured into them. Then carefully collect all the *Saltpeter*, and put it into any Vessel which is proper to hold it and preserve it dry. Then boil the *Lixivium* or Lye remaining in the Coolers over again, not forgetting to separate from it the Sediment at bottom, which may be laid aside for another Use.

If it happens to boil over, throw into it a little of other Lye, made of three Parts of the Ashes before mentioned, and one of Quick Lime, in every 100 lb Weight of which you must dissolve 4 lb of Roach Allum; and it will be necessary that you should have this *Lixivium* ready by you. Thus by throwing a little of this into the Boiler from time to time, as often as the Liquor rises, you will see it immediately fall, and the common Salt and Earthy Particles will precipitate to the Bottom.

The Earth remaining in your Vessel after all the Lye has past through it, must be put into some covered Place, where neither the Sun-beams, Rain, nor any kind of Water, can come near it, (though it is proper it should be frequented by Men or any Animals) where it may be scattered or spread to the height of a Foot. Then over this may be laid the Dung

of any kind of Cattle to the height of 2, 3 or 4 Feet. Then take all the Filth, Scum and Sediment, which you shall have separated from your Lye, during and after its Ebullition, together with what Liquor remains, after you have extracted what *Saltpeter* you can from it after repeated Boilings (separating from it the Terrestrious Matter and the common Salt, which subside, and which are good for nothing) and scatter or sprinkle them over your Dunghill, and every Day throw as much human Urine upon it as you can get; by doing which, your Soil will be as much impregnated with *Saltpeter* as it was at first, if not more, and which you may easily extract after the Method we have here given.

C H A P. III.

How to clarify or refine Saltpeter.

SINCE it is a received Opinion that Gun-powder ought to hold the first Rank of all those Things that are used in *Pyrotechnics*; and inasmuch as its powerful Force, and supernatural Effects, cannot be attributed to any moving Cause which is more active or strong than itself; and imagining that its chief Energy consists in a Separation of all gross and strange Matter from its purer Particles; I thought it not enough, barely to extract this *Salt* from a Saltpetrous Earth, but also to purge and cleanse it twice or thrice, or oftner if need be, that you may have it in the highest Degree of Perfection; and this you may do by two Methods.

The First. Be there taken as much *Saltpeter* as shall be thought fit, and put into a Boiler, then let there be as much fresh Water poured upon it as may be sufficient to dissolve it; on which must be poured a Quantity of that Lye, made by an Infusion of Ashes, Quick Lime, and Roach Allum, which we have already mentioned; let all this be boiled together till the *Saltpeter* is all diluted, and entirely reduced to a Scum or Froth. This done, let there be ready a Wooden Vessel, of sufficient Capacity, which must be placed in such a manner, that another may be set under it, the Bottom of the uppermost being perforated as before, and which Bottom must likewise be covered with fine, clean washed Sand, to the thickness of 3 or 4 Inches; over which spread a Piece of coarse Linnen Cloth. Then take the Liquor in the Boiler, and pour it into the upper Vessel, which will distill Drop by Drop into the Recipient beneath; and being thus strained through the Sand, covered with a coarse Cloth, it will leave all its gross and useles Particles behind. Afterwards pouring it out of the Recipient into the Boiler, let it boil again, as before, till it is ready to coagulate; then put it into broad and shallow Coolers, as we said in the foregoing Chapter, and let it cool at
leisure

leisure in some retired Place; and in two or three Days you will have your *Saltpeter* chryftalized much purer and finer than at first. If you would go on to refine it, repeat this Operation some few times more, after the same manner as we have proceeded in this first Purgation.

The other way of refining it is thus. Put your *Saltpeter* into a Boiler, made either of Copper, Iron, or glazed Earth; then set it on a slow Fire, which must be quickned by degrees till all the Salt is fused or melted, and boils up in great Bubbles; then take a little common Sulphur well pulverized, and throw it upon the liquified *Saltpeter*, which will instantly take fire, and consume all the oily and viscous Humour, together with all the droffy Salt which had been impregnated with the *Saltpeter* before its Clarification: This you may repeat several times till all those foreign Particles are entirely consumed. In short, the *Saltpeter* being well liquified and cleansed, you may pour it out upon polished Marble, or upon Plates of Copper, Iron, or glazed Earth, and it will be condensed to almost the Colour and Consistence of white Marble, or of pure and perfect Alabafter.

C H A P. IV.

How to reduce Saltpeter to a Flower.

THE *Saltpeter* having been refined, must be put into a Boiler, over a small Furnace upon burning Coals; then incessantly blow the Fire till it arrives to that Degree of Heat, that all the Moisture of the *Saltpeter* is evaporated in Fumes, and that it has attained a perfect Whiteness. But in drying it after this manner, you must take Care to stir it continually to the very bottom with an Iron or Wooden *Spatula*, lest it should return to its first Form. This done, pour fine, clear, fresh Water upon it, till it is covered; and when it is diluted and has acquired the Consistence of a dense Liquid, keep incessantly stirring it as quick and as fast as you can, till all the Moisture is evaporated *ad siccitatem*, and that it is all reduced to a very fine, white and dry *Flower*.

C H A P. V.

The manner of preparing Saltpeter with the Flower of Wall.

GET together a Quantity of that fine Flower which is commonly found upon the Surface of old Walls, that are in damp and subterraneous Places: You may also get some of that Salt, which frequently adheres to Lime, or the Ruins of old Buildings; which, *Peter Sardi*

says, he found to answer very well at *Brussels* in *Brabant*, in Book III. Chap. xxix. of his *Artillery*. You must first make a Lye of Quick Lime and common Water, which must be fined as usual; then having put your *Flower* or *Saltpeter* in a Vessel, with an Hole in the bottom of it, and ordered it in the same manner as we have directed in the second Chapter of this Book, throw your Lye upon it, and mix it well with a *Stapula* till the *Saltpeter* is all diluted; let this Liquor drop into the Recipient that stands beneath, and being all drained off, pour it into a Boiler, and heat it by slow Degrees over a Fire; then make it boil till it has acquired a sufficient Density, and that it will easily coagulate; then go on with your Process in the same manner I have directed above.

There have been even silly Girls who have had some Notion of this kind of *Salt*: An Instance of which we have from *Valerius*, *Lib. I. Cap. i.* where he speaks of a Disciple of the Virgin *Emilia*, who paying her Adoration to the Goddess *Vesta*, had put some shreds of fine Linnen upon a Chafing-dish, which, though the Fire in it seemed to be quite extinguished, broke out into pure and lively Flames. Now the Reason he gives for it is this; (says he) we must believe that this good Lady had put Scrapings of some old Wall, (or Flower of Wall as we call it) into this Linnen, and laid it upon warm Ashes, or else sprinkled them over with some of it, which broke out into those Flames, and produced that Effect; which raised the Wonder of those who knew not the Cause of it.

Furthermore, it sometimes happens that Fire takes hold of the Walls of certain Buildings with such Subtlety, as to astonish one, as if it were a Prodigy. This *Cardan*, (*Lib. X. of Varieties, Cap. xlix.*) attributes to the Salt, which usually adheres to the Surface of Walls, and Ruins of old Buildings.

C H A P. VI.

How to prepare Salprotic, or Pulvis Fulminans.

TAKE of *Saltpeter*, two or three times clarified or refined, a certain Quantity of Pounds, to each Pound add of *Sal Armoniack* $\frac{3}{4}$ ij, and of *Campfire* $\frac{3}{4}$ ls, and mix them all well together in some Brass Vessel; then pour upon them good *Brandy*, till they are covered with it to the height of 2 Inches. Boil them upon a quick Fire till all the Moisture is evaporated; then taking it from the Fire, put what remains into an unglazed Earthen Pot; cover it, and hang it up, placing under it a glazed Earthen Plate or Dish, into which you must carefully scrape a certain fine whitish Substance, very much like Flower of Wall, which will appear

pear upon the outward Surface of the Pot; you must continue to gather this white frosty Substance as fast as it penetrates through the Vessel that contains it. In short, having got together all of it that will perspire through the Pores of the Pot, put it carefully up in some dry Place till you want it.

C H A P. VII.

How to prove the Goodness of Saltpeter.

PUT some *Saltpeter* upon a Wooden Table, or some smooth Board, and set fire to it with a live Coal, and observe the Effects of it.

If in burning it makes the same Noise as common Salt does when it is thrown upon the Fire, it will be a Sign that it is still impregnated with a good deal of common Salt.

If it yields a greasy thick Scum, it is a Sign that it retains many viscid Particles.

If after its Combustion there remains any Filth, or Dross, upon the Board, it is a sure Token that it contains a great deal of Earthy Matter. In short, the more Dregs or Phlegm is left after the Combustion of the *Saltpeter*, so much the more impure and gross must you judge it to be, and consequently the less active.

But if, on the contrary, it breaks out into a long bright Flame divided into several Rays, and the Surface of the Board is free from any Dross; or if it be consumed to a pure Coal without any Scum; if it took fire without any great Noise, or violent Detonation; you may conclude that the *Saltpeter* is well cleansed and perfectly well prepared.

Joseph Furtenbach assures us, in his *Artillery*, that it is an infallible Sign of the Excellence of *Saltpeter*, if after the second Clarification, (according to the Prescription in the third Chapter of this Book, which is the usual Way of doing it) it loses 4 lb in 100 lb; and consequently after having been purified over again, according to the other Method laid down in the same Chapter, you will find it diminished 4 lb of its Weight, as before.



C H A P. VIII.

The true Method of purifying Saltpeter, and of separating from it all noxious and superfluous Matter; such as common Salt, Vitriol, Allum, and all gros and viscous Humours.

TAKE 2 lb of Quick Lime, 2 lb of common Salt of Verdigreafe, 1 lb of Roman Vitriol, 1 lb of Sal Armoniac. Pulverize them all together, then put them into some shallow Wooden Vessel, and pour upon them a good Quantity of Vinegar or Wine; or, for want of either of them, you may use clear fresh Water; and thus make a *Lixivium* or Lye, which you must leave to settle and fine of itself for three Days. Then put your *Saltpeter* into a Boiler, and pour as much of this Lye amongst it as will cover it; set it upon a gentle Fire, and let it boil till one half of all the Liquor is evaporated; then take it from the Fire, and pour what remains gently into another Vessel, and separate from it all the Dregs and Filth which sunk to the bottom of the Boiler. This done, let this *Saltpetrous Liquor* cool, and go on with your Process, according to the Rules we have prescribed in the third Chapter of this Book.

C H A P. IX.

How to purifie common Sulphur.

EXPERIENCE plainly evinces that not only *Saltpeter* is full of Earthy Matter; but that *Sulphur* also is not free from a gros, oily Humour, which Qualities are as noxious and prejudicial, as they are common to both the one and the other of them; therefore if you would have the pure Quintessence of these Ingredients, you must also purifie *Sulphur*, in order to exalt its Nature, and make it more fiery and aerial. In doing of which proceed as follows. Melt what Quantity you want of common *Sulphur* in an Earthen or Copper Vessel, over a slow, clear Fire; and, with a Spoon, gently take off all the Scum and Dross that swims on its Surface; then take it off, and filtrate it through a fine Linnen Cloth into another Vessel, squeezing it out pretty lightly. Thus all the Dregs and Oil of the *Sulphur* will remain in the Cloth, and you will have your *Sulphur* pure and clean after this Filtration. There are
some

some who, after having fused the *Sulphur*, and taken it from the Fire, have added to it a certain Quantity of Quicksilver, and then stirred them about as fast, and incorporated them together as well as possible, which they have continued to do till cold, that they might be the more closely and univerfally united; from whence we must believe that the Design of purifying it, is not only to render it more violent and active, but also that it may be the more volatile and subtile. There are others who, when their *Sulphur* is melted, mix Glass finely pulverized with it, and pour Brandy upon it, together with some Pieces of bruised Alum, imagining That greatly contributes to the refining of *Sulphur*.

You may know the Goodness of *Sulphur* by pressing it between two Iron Plates; for if in running it appears yellow like Wax, and emits no suffocating Scent, and if what stays behind is of a reddish Colour, you may conclude it to be natural and excellent. It is observed, that Fire is so fond of *Sulphur*, and that reciprocally, *Sulphur* takes such Pleasure in being devoured by that Element, that if any Bits of it happen to lye about any Wood, so as they can feel the Heat of it, they seem to call it to them, and really attract it sometimes. There is another kind of *Sulphur* which does not burn like the rest, and is not attended with any bad Smell, but being put upon the Fire melts just like common Wax. This sort of it is found in great abundance in *Ice-land* near Mount *Hecla*, and in *Carniola*; as *Libavius* relates in the first Part of the *Apocap. Hermet.* Now this Sulphur is commonly red, as is also that which is found in the Streights of *Heildesheim*, (as *Agricola* writes, *Lib. I. de Effl. Terr. Cap. xxii.* from the Testimony of *Job. Jonston, Adm. Nat. Clas. IV. Cap. xiii.*) where it is likewise of several Colours, as pale, yellow, and green, and generally adheres to the Surface of Stones and Rocks, and may easily be broken off and collected. That which is perfectly yellow is the best. We call that *Sulphur vivum* or *Quick Sulphur*, that has never been concerned with Fire; others call it *Virgin Sulphur*, because the Women and Girls in *Campania* usually make a kind of Paint of it to beautifie the Face.

C H A P. X.

How to reduce Saltpeter to an Oil.

LET there be put upon a Table, or Plank of Fir, that is well dried and planed, a certain Quantity of purified *Saltpeter*; then under the Plank or Table let there be set a Brass Bason, and under that some burning Coals; when the Fire melts the *Saltpeter*, you will see a Substance perfectly like an *Oil* flow from it, which will penetrate through the Wood, and drop into the Bason that is underneath. You may continue this Operation till you have enough of this *Oil*, provided that from time to time you add fresh Supplies of *Saltpeter*.

C H A P. XI.

How to prepare Oil of Sulphur.

TAKE a good Quantity of purified *Sulphur*, and melt it upon a gentle Fire, either in an Earthen or Copper Vessel. Then take of old red Tiles that have been used in some Building; but if you cannot get such, take new ones that are thoroughly burnt, and have never been wet; break them into Pieces of the bigness of a Bean, and throw them into the liquified *Sulphur*; mix them well together till the Pieces of Tile have absorbed or imbibed all that Liquid; then put them into an Alembick, over a distilling Furnace. Thus you will have a Chymical Extraction of your *Oil*, which will be excellent, very combustible, and proper in the Composition of artificial Fire-works.

A N O T H E R M E T H O D.

Take a Matrafs (the Fig. of which you have N^o 14.) and fill about a third or fourth Part of the Belly of it with *Sulphur* finely pulverized, pour into it Spirit of Turpentine, or Oil of Walnuts, or of Juniper, till, what with the *Sulphur* and the Liquid you pour upon it, you have half filled the said Matrafs; then set it upon hot Ashes, and let it there continue 8 or 9 Hours, and you will soon after see that the Spirit of Turpentine will turn the *Sulphur* into a red *Oil*, which will be as fiery and combustible as the former.

There are those who use the following Ingredients in the Preparation of *Oil of Sulphur* to make it the more igneous (*viz.*) of Sulphur 1 lb. of Lime lb ss, of Sal Armoniac ʒ iiij.

Besides this, the *Chymists* have a way of preparing a certain *Oil of Sulphur* (which they call a Balsam) whose Virtues are so admirable, as to prevent Putrefaction in any living or dead Body; and preserve them in so perfect and sound a State, that neither the pernicious Influences of the Heavenly Bodies, nor the Corruption caused by the Elements, nor even that which might naturally proceed from the very Principles of them, can in any degree impair or alter the Symmetry of such dead Bodies as are embalmed with it, nor of those that have been anointed with it whilst living. They prepare also a certain kind of Fire (as *Tribonius* tells us) with the Flower of *Sulphur* or Brimstone, of Borax, and Brandy, which will burn many Years without extinguishing. There are others who have a way of preparing a Lamp filled with some such Oil as this, which makes those it gives Light to appear without Heads.

C H A P. XII.

The Method of preparing a Mixture of Oil of Sulphur, with Oil Saltpeter.

TAKE equal Parts of *Sulphur* and *Saltpeter*, and incorporate them well together, then reduce them to a very fine Powder, and let them be searced: Put this Powder into an Earthen Pot that has never been used, and pour as much White-wine Vinegar, or Brandy upon it, as will be sufficient to cover it. Then lute up your Pot so closely that no Air can possibly enter in, and set it in some warm Place, where let it remain till the Vinegar is quite digested. Then take what remains in the Pot, and extract the *Oil* from it, with such Chymical Instruments as are proper for the Operation.

C H A P. XIII.

How to prepare Charcoal or Small-Coal for the Use of Gunpowder, and for other Uses in Pyrotechnics.

IN the Months of *May*, or *June*, when all sorts of Trees are easily stripp'd of their Bark, and more sappy than at any other time of the Year, cut down a good Quantity of *Filberd*, *Hazel*, or *Willow* Wood, of two or three Feet long, and half an Inch thick; throw aside all their useles Branches and hard Knots: then stripping off the Bark, tye them up in little Bundles or Faggots, and dry them in an hot Oven: which done, put them all upright in some even Place, and set fire to them; and as soon as you perceive they are thoroughly lighted and inflamed, cover them up quickly with wet Earth, which shall have been moistened for that purpose, so that the Fire may have no manner of communication with the outward Air. The Flame being thus stifled, and totally suppressed, you will have your *Coal* pure, and entire without Ashes. In twenty four Hours you may take it up, and lay it aside to be used in such Compositions as we shall mention hereafter. If it happens that you cannot get a sufficient Quantity of *Willow* or *Hazel* to make your Coal with, you may make it of *Lime-Tree* Wood.

But if you should not want any great Quantity of *Coal*, you may take Twigs of the Wood I have been mentioning, or *Juniper*, and cutting them into little Splinters, and then drying them well; put them into

an Earthen Vessel well luted with Clay; and encompassing it all round, and covering it a-top with burning Coals, let it continue in that State for the space of an Hour, taking care all the time to keep the Fire in an uniform Degree of Heat. This done; let it cool at leisure, and take out your *Coal*. There are those who take Pieces of old Linnen well washed and dried, and then burn it after this manner. The Virtues and Properties of this are not to be despised by the *Pyrotechnician*.

C H A P. XIV.

How to prepare Pulvis Pyrius, or Gun-powder.

THE Composition and Preparation of *Gun-powder* is not only very well known to such as are professed *Pyrotechnicians*, but likewise to many of those who never make use of it but for Musquets, Pistols, and such light Fire-arms. Nay, what is very odd, the very Peasants in our Country have learned to make it with their own Hands, without the help of any artificial Engines, or Chymical *Apparatus*. For (and I think it will not be very improper in this Place, to make the Digression) I have seen many of the Inhabitants of *Podolia* and *Ukrania*, whom we now call *Cossacks*, who make their own Powder, after a Method entirely contrary to the Practice of our *Pyrotechnicians*. For Example, they put certain Quantities of *Saltpeter*, *Sulphur*, and *Charcoal* into an Earthen Pot (the due Proportions of which they have attained to by long Use) then pouring fresh Water upon them, they boil them over a slow Fire, for two or three Hours, till all the Water is totally evaporated, and that their Composition is become very thick; then taking it out of the Pot, they dry it in the Sun, or some warm Place, in a thing like a Frying-pan. They then pass it through a Hair-sieve, and make it into very small Grains. There are others of them that pound their Composition, and incorporate it in an Earthen Porringer, or grind it upon some smooth polished Stone; then moisten it, and corn it, and bring it to such a degree of Perfection, that it serves them as well as if it had been prepared by the most ingenious Artist in the World.

It will therefore be to little purpose to dwell upon this Article, or to give a detail of the Preparation of our *Powder*; so I shall only present you with some excellent and approved Compositions for the making of three sorts of *Gun-powder*.

Composition for Cannon-Powder.	Composition for Musquet-Powder.	Composition for Pistol-Powder.
I.	I.	I.
Of <i>Saltpeter</i> - 100 lb.	Of <i>Saltpeter</i> - 100 lb.	Of <i>Saltpeter</i> - 100 lb.
Of <i>Sulphur</i> - 25 lb.	Of <i>Sulphur</i> - 18 lb.	Of <i>Sulphur</i> - 12 lb.
Of <i>Charcoal</i> - 25 lb.	Of <i>Charcoal</i> - 20 lb.	Of <i>Charcoal</i> - 15 lb.
2.	2.	2.
Of <i>Saltpeter</i> - 100 lb.	Of <i>Saltpeter</i> - 100 lb.	Of <i>Saltpeter</i> - 100 lb.
Of <i>Sulphur</i> - 20 lb.	Of <i>Sulphur</i> - 15 lb.	Of <i>Sulphur</i> - 10 lb.
Of <i>Charcoal</i> - 24 lb.	Of <i>Charcoal</i> - 18 lb.	Of <i>Charcoal</i> - 8 lb.

As you pound or grind your Mixture of Cannon or Musquet Powder, you may sprinkle it gently with fresh Water only, or Vinegar, Urine, or Brandy. But if you would have your Pistol Powder stronger than ordinary, you must now and then sprinkle your Composition whilst it is in the Mortar with the following Liquor; or with Water of Orange, Citron or Lemon Peel, distilled with an Alembic or any other Chymical Organ, and let it all be well pounded or ground for the space of 24 Hours; then corn it very finely.

Now this Liquor is made of 20 Measures of Brandy, 12 Measures of Effence or Spirit of White-wine Vinegar, 4 Measures of Spirit of Nitre, 2 Measures of common Water of *Sal Armoniac*, one Measure of Camphire dissolved in Brandy, or pulverized with Sulphur, or in short reduced to an Oil, with Oil of sweet Almonds.

In the second Part of our *Artillery* I shall give you the *Figure* of the Hand-Mill which is used in making *Gun-powder*, together with a great many other Machines and Engines, which are usually reserved in *Arsenals* and *Magazines* of *Artillery*.

It is a strange and most astonishing Property of *Gun-powder*, that it should have a more violent Effect when corned, than when in a fine Flower or Meal; the Reason of which I shall leave to the Discussion of those, who make it their particular Business to insinuate themselves into the wonderful Secrets of Nature. I content myself with having been taught by long Practice; that if in any Gun the Powder be rammed down too hard, so that the Corns of it lose their Figure, or are in the least pulverized, it will by that means be divested of much of its Force, and will not drive out the Bullet, with that Violence it would have been capable of, if it had been gently pushed down to the Bottom of the Piece; and we have sometimes observed, that its Power has been so far diminished by this means, that it has hardly been able to overcome the Resistance of the Bullet, and dislodge it from the Piece. The same thing happens if Powder is wet, which being thereby deprived of its Expulsive Force, burns lazily and without Effect; so that if any Piece be charged with it, and you set fire to it, it will be so far from being able to

to drive out the Ball that it will all burn out at the Touch-hole. How it comes to pass that *Gun-powder*, by being bruised, and reduced to a soft Flower or Meal, loses thus its Virtue and Activity; must be owing to the Rays of Fire, which though it be the most subtle and active of all Elements, yet is not sufficiently fine to penetrate and enkindle at once a hard compacted Body at the very Moment it seizes upon it. This Assertion needs no Proof to confirm it; for Experience shews us, with regard to Metals, that the more solid and hard they are, the less easily are they acted upon by Fire; on the contrary, such as are more porous, and loosely compacted, are quickly heated; which is to be attributed to the Largeness of their Pores, which readily admit the Fire. This may be applied to *Gun-powder*; for when it is rammed and compelled into a solid Body, the Fire not meeting with Interstices proper for its immediate Conveyance through the whole Mass, it is obliged to consume it by degrees, as long as any of it remains, except it be suffocated. Something of this kind may be said of *Powder* that is scattered about, and is not gathered together before it is fired; but nevertheless with this difference, That in this Case the essential Strength of the *Gun-powder*, or rather the Fire in it, is not any way diminished, but its Action is ineffectual because of the Distance of its Parts; it acts in this Case by a Succession of small Action, which might have been considerable if collected together into one Act. Those who are but little versed in *Pyrotechnics*, may have experienced the Truth of what I have here said. The Reason I have given why *Powder* when it is corned is more active and powerful than when pulverized, may serve in some measure to clear up that Difficulty; add to which, the Virtue of the *Saltpeter* seems to be much more united with the *Sulphur* and the *Charcoal* when in a close Corn, than when meal'd or pulverized. To this let us add, that if you take a very long Piece of Cannon, and fill it up to the Muzzle with well-corned *Powder*, and set fire to it at the Muzzle, and not at the Touch-hole as usual; neither the Fire nor the Powder in this Case will do the least Damage to the Piece, inasmuch as the Fire acts upon the Powder by Progression and not Instantaneously; besides the Fire will move downwards, which is the reverse of its natural Property of acting upwards; or to speak more properly, it not being closely confined, and meeting with nothing to obstruct its perfect Liberty, it burns out at the Muzzle of the Piece.

I shall silently pass over the Opinion of some who are not very knowing as to this matter, and who imagine the larger any *Gun-powder* is corned, the more lively it will be: Which at first does not appear unlikely, and seems to agree with what I have been saying above: But on the other side, the Consequence of it is wrong; because large Grains are not so readily accended, or inflamed, as small ones; and Experience in Fireworks teaches us, That that *Powder* which is in the least Corns, is more vigorous than that whose Grains are the largest; and the Reason is, because the small ones conceive the Fire more readily: Add to this

this, that they are more impregnated with *Saltpeter* (the very Life of it all) than the others; and hence it is that they corn it small for the Musquet and Pistol, &c. and on the contrary take less trouble with it, when designed for the Use of Cannon; for as all great Pieces of Ordinance naturally require a much greater Quantity of *Powder* than the small portable Fire-arms, it is but reasonable that the *Powder* prepared for the former, should be coarser than that designed for the latter; and indeed it is not only reasonable but necessary likewise, to the end that its Interstices being the larger, the Fire may have the better Convenience of penetrating through the whole Mass of it, and of accending it at once. Now *Nicolas Tartaglia* in his Book III. Quest. 10. gives this Reason why Musquet and Pistol *Powder* ought to be corned: It is (says he) to the end, That that Quantity of *Powder*, which is the exact Charge of such Arms, may be more conveniently poured out of the Bandeliers (which are little wooden Measures to hold just a Load) and that it may run the more freely down the Barrel of the Piece; (although the Bandelier is exactly of the same Calibre as the Piece,) which could not easily be done if the *Powder* was in a Flower or pulverized, because the small Particles of it cohering together, it would all tumble down at once into the Barrel, and meet with some Difficulty in its Descent, particularly if the Priming-pan was shut close; for in that Case it would happen that the Air in the Bottom or lower part of the Barrel having no Opportunity of escaping out at the Touch-hole, and the Density of the descending Flower not admitting of its Excursion upwards, it would in the end be so violently compressed as to repel the *Powder* or Flower by its Elastic Force, so that it would be impossible to load such Arms with it, with any manner of Expedition: But this Accident never happens with regard to grained *Powder*, inasmuch as the Air in the Barrel is at perfect Liberty, by having the Power of escaping through its Interstices: However, great Pieces of Artillery are by no means liable to this Inconvenience; because the *Powder* is always conveyed into them by a Ladle. Here is a way of Reasoning that has some shew of Truth on its side; though it is far from accounting sufficiently for the Necessity of corning *Gun-powder*; but he is most strangely out of the way, when he says, that *Cannon Powder* need not be corned at all; which I absolutely deny, and cannot but think, from his wretched manner of arguing, that He (*Tartaglia*) was so far from having ever heard or seen the wonderful Effects of *Cannon Powder* upon such perilous Occasions, as the Wars in his time abounded with, that he never had so much as a Sight of any of the *Powder* itself.

C H A P. XV.

How to make Gun-powder of several Colours.

THE Blackness of *Gun-powder* is entirely owing to the Charcoal; but that Tincture is no necessary Adjunct to its Nature, nor does it so far contribute to the strengthening of it, but that you may make it of several Colours with equal Success. For Example; if instead of Charcoal you take rotten Wood, or white Paper that has been first moistened, then put into an hot Oven, and after that pulverized, or any thing else that is of a very combustible Nature, and very susceptible of Fire (such as I am going to speak of) you will have a *Powder* to the full as effective as the Black Sort. I shall then in this Chapter present you with some Compositions, to guide you in making *Powder* of several Colours.

To make White Powder.

1.

Take of Saltpeter 6 lb, of Sulphur 1 lb, of the Pith of Elder well dried one lb.

2.

Take of Saltpeter 10 lb, of Sulphur one lb, of the Rind or Bark of Hemp, after the Hemp is taken out, one lb.

3.

Take of Saltpeter 6 lb, of Sulphur one lb, of Tartar calcined till it is White, then mixed with common Water, and put into an unglazed Pot in which it must be boiled till all the Water is evaporated, ʒj.

Red Powder.

1.

Take of Saltpeter 6 lb, of Sulphur one lb, of Amber lb ss, and of red Sanders one lb.

2.

Take of Saltpeter 8 lb, of Sulphur one lb, of Paper dried and pulverized, then boiled in Water of Cinnabar, or Brasil Wood, and then dried, one lb.

Yellow Powder.

Take of Saltpeter 8 lb, of Sulphur one lb, of wild or bastard Saffron, first boiled in Brandy, then dried and pulverized, one lb.

2

Green

Green Powder.

Take of Saltpeter 10 lb, of Sulphur one lb, of rotten Wood boiled with Verdigreaf and Brandy, and then well dried and pulverized, 2 lb.

Blue Powder.

Take of Saltpeter 8 lb, of Sulphur one lb, of the Saw-dust of Linden or Lime Tree *Wood* boiled with Indigo and Brandy, then dried and pulverized, one lb.

C H A P. XVI.

Of Silent Powder.

SOME People have taken it into their Heads to relate a great many wonderful things of this *Silent Powder*, (which is by some very improperly called *Deaf Powder*) and have treated of it in a very prolix Manner: To avoid which, and to prevent my being tiresome to the Reader, I shall here only insert some Compositions, which I have found to be the most excellent and best approved of.

I.

Take of common *Gun-powder* 2 lb, of *Venetian Borax* one lb; these Ingredients being well pulverized and incorporated together, let them be afterwards corned.

2.

Take of common *Gun-powder* 2 lb, of *Venetian Borax* one lb, of *Lapis Calaminaris* lb ss, of *Sal Armoniac* lb ss; pulverize and incorporate them well together, and corn them as before.

3.

Take of common *Gun-powder* 6 lb, Powder of live Moles calcined in a glazed earthen Pot lb ss, of *Venetian Borax* lb ss.

4.

Take of Saltpeter 6 lb, of Sulphur 8 lb and $\frac{1}{2}$, Powder of the inner Rind or Bark of Elder lb ss, of common Salt burnt 2 lb. Corn all this after the usual Method.

I shall to this add another thing which you may make the Experiment of; for my part I never did, though it is taken out of the *Natural Magic* of the *Sieur de la Porte*, who says, that if you add burnt Paper to the Composition of *Gun-powder*, or the double of common Hay Seed, well beaten, it will weaken it very much, and prevent it from casting out so much Flame, or making so much Noise. People of Sense, and such

such as are the most deeply versed in this Art, attribute the Noise or rather the frightful Clamour of *Gun-powder*, to the violent Concussion of the Air, which is impatient of being so furiously disturbed, by such a strange and extraordinary Agitation: But of this we shall speak more fully in another Place. However in favour of *Silent Powder*, I must here quote the Opinion of *Scaliger*, taken from *Lib. XV.* in his *Exer. Exoter. contr. Card. de Subtil. Exer. XXV.* *You are much more out of the way to attribute the Noise heard upon the Discharge of Warlike Machines to Saltpeter; for being reduced to a fine Meal it loses all its little Caverns or Pores.* (You must here remember what was said above of the Detonation of Saltpeter.) *Thunder is caused by the Complosion of the Air, as well with respect to its Clap as its Sound; which sometimes provokes Mirth; sometimes excites Laughter, and obliges us to shut our Nostrils together. Except you would persuade us that there is Saltpeter above us: But truly there is none in the Clouds. The Powder which you mention to have been invented at Ferrara, made no Noise; because it impelled without Violence.*

From hence it is easy to conceive what may be the Cause of the Noise which *Gun-powder* seems to make. For there is nothing further extraordinary in the Composition of *Silent Powder*, than that certain Ingredients, a great part of which I have mentioned in this Chapter, have an occult Antipathy to *Saltpeter*, and weaken the common *Powder* when mixed with it. Farthermore, there are some Persons who affirm, that if you besmear your Hands with the Gall of a Pike, and immediately handle and mix *Gun-powder* about with them, it will have that weakening Effect upon it. But I shall leave this, to those who have Faith enough to rely upon the Authors who have made the Experiment. Thus we find by the above Passage from *Scaliger* upon this Subject; That *Gun-powder* does not make that shocking Detonation, which is heard when any of those Warlike Machines are discharged: But that it is owing to the violent Complosion of the Air, which is dispersed by the firing of the Piece. We cannot give you a more familiar Instance of the Truth of this, than the Wind-Guns which are charged with nothing but Air.

C H A P. XVII.

How to prove the Goodness of Gun-powder.

THERE are three different ways of proving *Gun-powder*, (*viz.*) by the *Sight*, the *Touch*, and by *Fire*. As to the first; when you perceive your *Powder* more black than usual, it is a certain Sign that it is too moist; and if you put it upon some white Paper, and find that it

blackens it, you may assure yourself that there is too much Charcoal amongst it; but if it be of a deep Ash Colour; inclining a little to the Red, it is a sure Token that your *Powder* is good.

We try *Gun-powder* by the *Touch* after this manner. Bruise some Grains or Corns of it with the end of your Finger, and if it readily disperses and yields easily to the Pressure of your Finger, you may conclude that there is too much Charcoal in it. If upon squeezing, or pressing it a little strongly, upon a marble or smooth wooden Table, you feel Particles that are harder than the rest, which prick you a little, and that cannot be crushed without some difficulty, you may infer that the *Sulphur* is not well incorporated with the *Saltpeter*, and that consequently the *Powder* is not duly prepared.

In short, you may determine with the utmost Certainty concerning the Goodness or Badness of your *Gun-powder* by means of *Fire*, as follows: Lay little Parcels or Heaps of *Gun-powder* upon a clean smooth Table, at the distance of about 2 or 3 Inches from one another, and set fire to one of them; which if it blows up at once, without catching hold of any other Parcels, and makes a little sort of an acute Noise, or produces a white, clear Smoke, rising with a very sudden Velocity, and appearing in the Air like a little Circle or Diadem of Smoke; you may depend upon its being perfectly well prepared.

If after the *Powder* is enkindled there remain any black Spots upon the Table, it will be a Sign that there is a great deal of Charcoal in it which has not been sufficiently burnt; if the Board is as it were greasy, you may be assured that the *Sulphur* and *Saltpeter* have not been sufficiently purified, or purged of that noxious and viscous Humour, which is natural to both the one and the other of them. If you find any small Particles which are white, or inclining to Lemon-Colour, it will be a Mark that your *Saltpeter* is not well clarified, and consequently that it still retains earthy Particles, or common Salt; and moreover, that the *Sulphur* is not pounded or ground fine enough, nor sufficiently incorporated with the two other Ingredients of the Composition.

I shall not here speak of several kinds of Instruments, which *Pyrotechnicians* commonly make use of to prove the Strength and Virtue of their *Gun-powder*: Having often heard that equal Quantities of one and the same sort of *Powder*, have blown up that which covered them, to several, and different degrees of height. You may, if you please, see the *Figures* of some of them in *Furtenbach*, and others.



C H A P. XVIII.

How to fortifie weakened Powder, and to restore that which is damaged to its first Vigour.

WE call that, damaged, decayed, or weakened *Powder*, which is much degenerated from its first Vigour, and the Strength it was indued with at its first Preparation. We can attribute its Decay or Imbecility to no other Cause, than to the Weakening, or Diminution of the natural Virtue of the *Saltpeter*, or else to its actual Separation from the *Sulphur* and *Charcoal*. And this may be owing to two several Accidents, (*viz.*) to its being either superannuated or too old, or to its being too moist. I say superannuated; because the *Saltpeter* is greatly affected by the Decay of the *Charcoal*, which is naturally subject to Corruption after a certain term of Years. Then as to Moisture, it is a means of making the best part of the *Saltpeter* separate itself from the *Sulphur* and *Charcoal*; because as *Saltpeter* is generated from a Water, or from a certain Saline Humour, (just as all other Salts are respectively produced from theirs) it dissolves, and returns to its first Form, whenever it is any way affected by Humidity: And thus withdrawing itself from the two other Ingredients which adhered to it, it either exhales, or sinks down to the bottom of the Vessel in which it is kept (if it be made of Clay, hard Stone or Earth) where being subsided it remains; and therefore in this Case the *Powder* towards the Bottom is heavier than that towards the Top. But if it be kept in Casks, Barrels, or any thing made of Wood, it perspires through the Pores of that light, or rare Substance, and re-assumes its original Nature; and consequently leaves the rest of the Composition the lighter by its own Weight, which before constituted the greatest part of the Weight of the whole. But in this Case, neither the *Sulphur* nor *Charcoal* will be diminished in Weight; because it is not in their Nature to be dissolved by any Moisture: on the contrary, *Charcoal* attracts and imbibes it greedily, and thereby becomes the heavier. Now if you would restore *Powder* that begins to decay, or reinstate that which is perfectly spoiled, in its first Vigour, you may do it after three ways: and First, Make a Lye with 2 Measures of Brandy, one Measure of purified *Saltpeter*, one Measure of good White-wine Vinegar, $\frac{1}{2}$ a Measure of *Salprotic*, $\frac{1}{2}$ a Measure of Oil of Sulphur, and $\frac{1}{2}$ a Measure of Camphire dissolved in Brandy; this *Lixivium* being strained through a coarse strong Searce, sprinkle or moisten your damaged *Powder* frequently with it, and dry it in the Sun in wooden Vessels, then carry it into some warm dry place where no Damp can come at it.

The

The Second Method of recovering decayed *Gunpowder* is this. First, see how much your damaged *Powder* has lost of its Weight, and upon finding the Difference between its Weight now, and when first made, supply the Difference with an equal Quantity of fine purified *Saltpeter*; as for Example; let the Weight marked upon the Cask be 1000 lb, and if upon weighing it now, you find that it is but 920; the Difference between the first and second Weight will be 80; therefore you must add 80 lb of *Saltpeter* to the vitiated *Powder*; then put it all in little Heaps, and pound it, or grind it well after the usual manner, and corn it as before.

In short, the Third Method of restoring weakened *Gunpowder* is as follows, and is the simplest of them all, and the most frequently practised by *Pyrotechnicians* and Powder-Makers. Pour out upon coarse Cloths, or well-jointed Planks, equal Proportions of damaged *Powder*, and such as has been newly made, and mix them briskly together with your Hands, or Wooden Shovels; then dry it all in the Sun, and putting it up again in your Barrels, keep it in some convenient Place till it is wanted.

C H A P. XIX.

Of Buildings and Magazines for the preserving of Gunpowder, together with several Observations on the stowing, and keeping it secure from Fire, Moisture, &c. to the end that it may remain entire, and in the full Possession of its first Vigour.

AFTER a strict Examination of the Warlike Machines of the Ancients, we must allow that they fall short of our *Artillery*, which has been in use for these last Ages: Our *Gunpowder* is now the very Nerves and Life of War; and is the most powerful Means that has ever yet been invented, of procuring an happy Issue to the Military Enterprizes of Princes, and to decide the Disputes of the most Mighty Monarchs of the Earth. But you will say, that our Machines are useless inactive Bodies, if you deprive them of *Gunpowder*, or if you supply them with such as may be ill-prepared, or damaged: Therefore it is of the highest Importance, that we be careful in the Preparation and Conservation of it; and so to order Matters, that such a costly Thing may not fail of performing the Service and Execution you expected from it. I have spoken sufficiently of the Preparation of it in the xivth Chap. of this Book; but I do not think of closing it till I have said something farther upon that Article. In the mean time let us consider of a proper Situation for our *Repositories* or *Magazines* for
 keeping

keeping *Gun-powder*, together with the proper Form and Construction of such *Buildings*, that they may be exempt from those Accidents which may have the most dangerous Effects upon them.

You must, in the *first* Place, pitch upon a Spot of Ground, which is far from any Marsh or Swamp; which is not in a narrow close Valley, nor in the Neighbourhood of any Spring or Pond; but let it be upon a moderate Height, in an open Country disincumbered with Woods, and very dry.

Secondly, let it be as far as possible from any other *Buildings*; because of several Inconveniencies that may arise from their Proximity; again, let it be in an unfrequented Place, at a good distance from any Roads or publick Paths, where People commonly resort.

Thirdly, let it be well covered and defended from any Danger of the Enemy's Cannon; which may be easily provided against, by building your *Magazines* in that Quarter of the Town, which shall be judged the most difficult of Access, and the least subject to the Attacks and Storms of the Besiegers. As for Example, in any Place that is encompassed with a Morass, or Lake, or a wide rapid River, or in short by the Sea itself. In the other Quarter of the Town which is the most defenceless, and consequently the most in danger of the Enemy's Attacks, you should build very high Houses and Edifices, whether Publick or Private, in order to cover your *Magazines* from the Besieger's Batteries, and keep them out of their Sight. For this Reason your *Magazines* should be but one or two Stories of a moderate Height, and covered with a low Roof.

In the *Fourth* Place, let them be in the middle of your Curtains, and not in the Bastions, or near Bulwarks; that you may avoid the danger of Mines, Galleries, and secret Saps of the Enemy; or in short at the greatest distance from the Ramparts of the Town, that you may be so much the safer.

In the *Fifth* Place, these *Buildings* shall be closed up with strong, thick Vaulting within, very firmly cemented, lest during the Siege any Bombs or Shells, &c. falling upon them, should force a Way through, and be attended with pernicious Consequences to your Powder. The Roof must not be covered with Laths, Slate, or Tiling of any sort, but with Sheet-Lead, or (what is much better) with substantial Plates of Copper. Again, I would have the Outside of the Roof be of a Spherical Form, that you need not be obliged to have any Carpenter's Work in it; such as Beams, Timbers, Planking; but that the Tiles, or whatever else covers it, may be fixed upon a strong Wall, securely cemented on all Sides with good Mortar.

Sixthly, a Square *Building* will be the most convenient of any Form or Figure whatsoever; though I do by no means disapprove of such as are built Round, or in Form of a *Dome*, as being the most capacious of all, and over which the strongest Vaults may be built, because of the

Rotundity of their Construction. But if you would build a square one, take care to erect the four Fronts of it, facing the four Quarters of the World.

Seventhly, let the Door be always on the North-Side.

Eighthly, let the Apertures or Windows be as small as possible, very narrow, and secured with strong Copper or Brass Bars, substantial Shutters, and strong Grates of the same Metal.

Ninthly, let the Bricks you intend to build your *Powder Magazines* with, be two Years old before you use them, and take great care that they be not hastily dried in the Sun. We are of Opinion, that Bricks which have been burned once, then moistened, and burnt over again, are by much the best of any, though they are not naturally so tenacious of the Mortar; for it has been observed, that if they are plastered either withinside or without, the Lime or Plaster does not stick upon them long.

Tenthly, and lastly; Your *Magazine* being built, erected, and covered, or roofed, as it ought to be, you shall let it stand and dry for the space of two or three Years, before you put any *Powder* into it; and take care not to build it in Winter-time. *

You will see the *Ichnography* and *Orthographic* Plan of this sort of *Buildings* in *Fig. 15* and *16*. In the *Ichnographic* Figure, the Letter A shows the Room or Apartment, where the *Powder* ought to be kept; B, where the *Saltpeter* and *Sulphur* ought to be reserved. And C, where the *Charcoal*, and other Materials and Necessaries may be laid up, such as *Searces* or *Sieves* of several sorts, some for sifting, and others for graining the *Powder*, old Pieces of Linnen, Canvass, Boards, or Flooring to dry it upon: And as the Rooms will be sufficiently extensive and large, you may in the same Place stow away empty Casks, or Barrel-Staves, Heading, Hoops, and such like Requisites. D, is the Winding Stair-case, which the *Italians* call the *Lumaca*, by which you go up into the second Story. E, is the Entrance or Portico. F, the Store-keeper's Lodge, or House, who ought to be a Cooper by Trade. G, the Steps. H, the Court, or Yard, which goes round the *Magazine*. I, a little Wall six or eight Foot high, that encloses the Yard and the *Magazine*. K, the empty Spaces, Passages, or Alleys, between the *Powder* Barrels, and L the Spaces where the *Powder* must be stowed. The other Distances may be measured with a Pair of Compasses, as well upon the *Ichnographic* as the *Orthographic* Plan. I shall only add, that the *Match* may be conveniently preserved upon the Floor of the second Story.

In *Fig. 17*. you have the *Ichnography* of a *Powder Magazine*, after the Design of *Eugenius Gentilius* an *Italian*, who has very curiously represented one of this Nature in Chap. xlv. of his *Artillery*; and is very conveniently contrived against all Accidents by Fire. Let us a little explain the Plan which we have here offered. A, is the Inner-wall

of the *Building*, with its Apertures and Lights. B, is the Outward Wall, with Apertures corresponding with the First. C, is the Space between the two Walls. D, E, is the outward Breadth of the Aperture of the Exterior Wall of three Feet. F, G, is the Breadth of it inwards of $1\frac{1}{2}$ Foot. I will now direct you how to make the Apertures in the Inner Wall of this *Building*. Let there be drawn from H, to I and K, two Lines each equal to D E, or three Feet: Now if between the Points E I, and D K, you produce the Right Lines E I and D K, they will intersect the Inner-Face of the Interior Wall in the Points L and M; then let there be drawn two Lines equal to F G, or $1\frac{1}{2}$ Foot, from the Points L and M, to the Points N and O; then having drawn two Right Lines from H to L and M; if you raise a Perpendicular upon N, and another upon O, they will intersect the Lines L, H, and H, M, in the Points P and Q. Thus having drawn D F, E G, I L, O P, P H, H Q, Q N, and M K; you will have the Inward and Outward Breadths of the Lights marked out. I must own that this kind of Edifice will be a little dark, on account of the double Wall, and because the Inner Lights L, O, and N M, are exactly covered by the Angles I and K, and consequently cannot let in much of the Day; besides that the Angles P and Q, intercept half of the Light which would otherwise come to L O, and N M; but on the other hand we must consider, that these Buildings stand in no need of a great deal of Light, like such as are designed for Dwellings; for if there is but just sufficient of it, to direct those who go in and out about the necessary Business of the Place, it is enough. Again, the Wind coming in at D E, striking against the Angle H, and being broken and divided towards the Angles I and K, will rush briskly in through the Apertures, and refresh the Air which was in before, and at the same time drive away and dry up all that noxious Moisture to which such close Places are commonly subject. As for the necessary Precautions of securing your *Magazine* from Accidents by Fire, you will easily defend it from that destructive Element, if you nicely observe what we have already laid down, in the Construction of your Vaults and Roof; for as to the Apertures or Windows, they are so well contrived against any danger of that kind, that it is impossible for any Fire to insinuate itself through them by any Artifice whatsoever.

You may order the Door of your *Magazine* after this manner. The Outward Breadth T U, in the Exterior Wall, and the Inward Breadth R S in the same, shall be each three Feet. Then from the Angle W, having produced Right Lines to the Points X and Z, and from T and U, to A and Y, you will have the Outward and Inward Breadth of the double Entrance through the Inner Wall. The rest will be better apprehended from the *Fig.* itself, if you attentively consider it. I shall only add, that B b, denote the Spaces where the *Powder* ought to be lodged, and C c the Passages between. As to the Orthography of this Edifice, and all the Proportions of its Parts, they may be invented

at Pleasure: Nevertheless I would have every body to follow the Instruction and Method of this Author, whose Name I have already mentioned. This is what I had to say of the Construction of *Magazines*, and proper Edifices for the lodging and preserving of *Gun-powder*: Let us now proceed to order what ought to be observed, as well in the Preparation, as the Conservation of it after it is made.

Know then First, that if you would have your *Gun-powder* retain its full Vigour, even though you should lodge it in some damp Place, there to remain for some time; you need only have *Saltpeter* well pulverized and purified several times, according to the Method we have prescribed in the III^d Chapter of this Book.

2. Let each Ingredient have its own Searce for its particular Use.

3. Your Ingredients shall not be mixed till they have been first well dried, ground, and searced seperately; which done, they shall be well ground, incorporated, and searced all together over again.

4. In pounding, or grinding them, they shall be moistened a little with one of the Liquors I have already mentioned, and shall be often and carefully shaked, or stirred, that they may incorporate the better together.

5. Your *Powder* being well and duly prepared, shall be put into glazed Earthen Jars, capable of containing each 100 lb, or thereabouts, with Covers of the same, well luted on the Outside with Glutinous, Bituminous, or any Tenacious Matter, to prevent the Air, or any outward Accident from doing it hurt. I approve very well of Casks or Barrels, made of *Fir* or well-dried *Oak*.

6. Your Vessels of *Powder* shall be placed upon Blocks, or Logs of Wood, of the thickness of one or two Feet.

7. Every Year during the hottest Months, such as *June*, *July*, and *August*, you shall spread your Powder upon Canvass, or a Floor of Planks made for that purpose, and let it dry well in the Sun and Wind, then sift it through fine covered Hair Sieves or Searces, and collect the fine Flower or Meal that comes through; but that which remains in Corns shall be put up again and covered as before, and carried back again into the *Magazine*.

8. The Cavities and Windows must be opened to the Northerly and Easterly Winds, that they rushing in briskly may purifie the Air confined within. On the contrary, they shall be kept close against Southerly and Westerly Winds, as being commonly pernicious to dry Things. For Experience, that Mistress of Knowledge, teaches us, that the Winds blowing from those Quarters being naturally hot and moist, they generally beget Taint and Putrefaction in *Flower*. And farthermore, you must guard against all Winds blowing from the East towards the South, and from the South towards the West; because all Winds issuing from any Point of that Semi-circle, fill the Air with unwholesome moist Vapours, which are of hurtful Efficacy to the Human Body; and we may reason-

reason-

reasonably infer, that as *Saltpeter* is extremely subject to Dissolution upon the access of any Humidity to it, those Winds must have pernicious Effects upon *Gun-powder*.

To conclude; I dare venture to affirm that if the Rules I have now prescribed for the Preparation and Conservation of *Gun-powder* are strictly observed, you may keep it many Years in full Possession of its first Vigour, without suffering the least Diminution of its Strength. And I flatly deny the Truth of that vulgar Notion, which teaches that *Powder* cannot be kept in Perfection above 2 or 3 Years. There are those who say that if you put a little Camphire in each of your Vessels of *Powder*, it contributes greatly to its Preservation. This is not unlikely, since the odoriferous Smell and extream Dryness of Camphire strongly repel all Putrefaction and Corruption which is generated by damp Vapours. It has been frequently observed, that Compositions have been taken out of Grenado's and Shells of long standing, which have been in perfect good State, and smelt much of Camphire. From whence we may conclude, that a Mixture of Camphire with *Gun-powder* contributes pretty much to its Preservation. But I shall speak more largely of this in another Place.

C H A P. XX.

Of the Properties and particular Offices of each Ingredient concerned in the Composition and Preparation of Gun-powder.

WE must not think that *Gun-powder* was casually, or accidentally discovered; but on the contrary, that it was invented and perfected, by sound speculative Reasonings, drawn from the Principles of *Natural Philosophy*; inasmuch as no Man to this Day could ever yet (though many have endeavoured at it) contrive an Assemblage of three such Ingredients as these, which being united and incorporated together, would naturally produce so vigorous, so frightful, and so sudden a Fire, and at the same time so inextinguishable, and universally absorbant of their own Substance. Now as it is no Novelty in our Age, for Men to add to, and enlarge upon preceding Inventions, and since (as the *Metaphysicians* have it) all Things that have a Beginning pass from Imperfection to Perfection; I beg leave to make some Observations upon *Gun-powder* (the Inventor of it having left nothing in writing behind him concerning it) which though they are indeed speculative, are nevertheless grounded upon Experience of the Nature, Effects, and particular Properties of all the Ingredients which enter into the Composition of

Fig. 11.

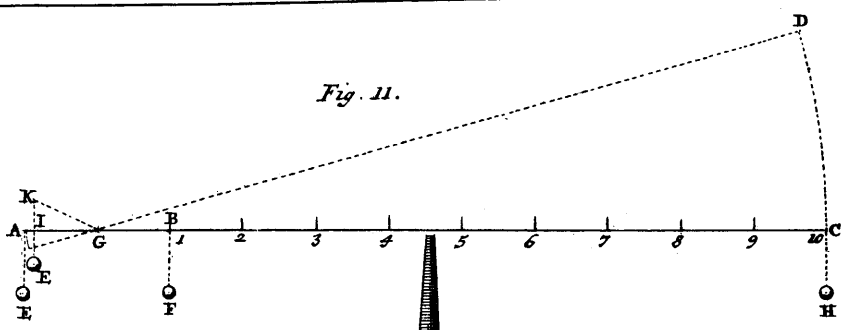

Fig. 12.

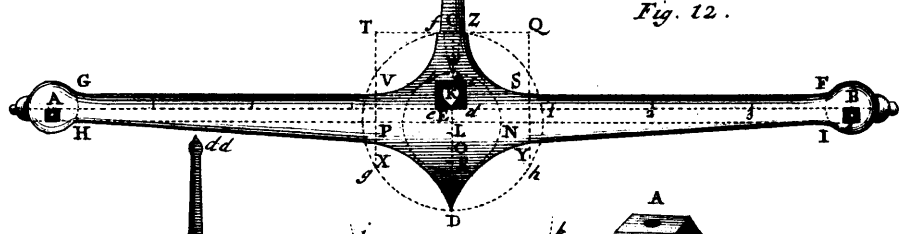

Fig. 13.

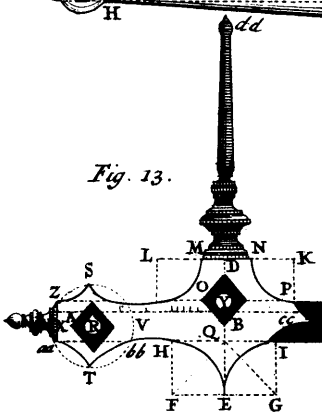

Fig. 15.

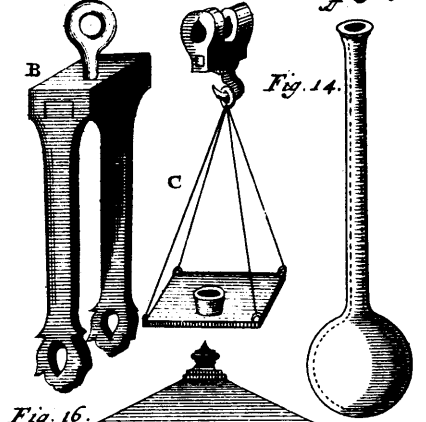
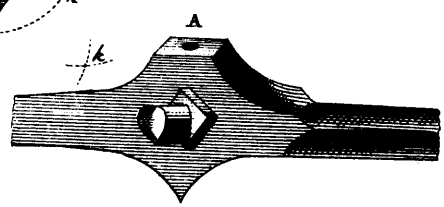
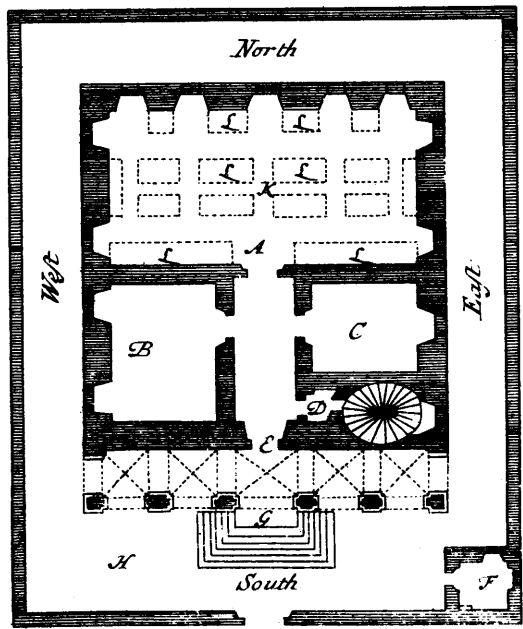
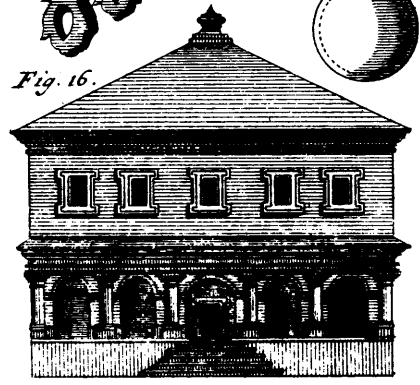
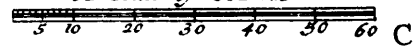

Fig. 14.

Fig. 16.



A Scale of 60 Feet.



it, as well when separated from one another, as when united into one Body. For I cannot but think that a few Words upon this Subject, will be so far useful, if well digested, as to prevent the frequent Errors committed in *Pyrotechnics*; a Correction of which is not only very dangerous, but likewise very expensive.

You must know then, *First*, that it is not without Reason, that *Gun-powder* is composed of these three Ingredients, namely, *Saltpeter*, *Sulphur*, and *Charcoal*; but to the End that one of them might remedy and supply the Defects of another, or of the other two. This may easily be comprehended by the Nature and Effects of *Sulphur*, which is of itself the very Quintessence of Fire, or rather a pure Flame, and is therefore more proper to accend the *Saltpeter* than any other Fire whatsoever: But as *Saltpeter* being once inflamed by it, is instantly rarified into a *Flatulent* or *Windy Expansion*, it would by its Violence infallibly extinguish the Flame which had been conceived by the *Sulphur*, and deprive itself of that Heat which the *Sulphur* would have communicated to it: And therefore if a Composition was made of *Saltpeter* and *Sulphur* only, well pulverized and incorporated together, it would indeed most readily conceive the Fire, and break out into a Flame, but it would instantly go out again, for the Reason above given: That is, the Fire would not be sufficiently lasting to consume the whole of it, but would only destroy a Part, without affecting the rest. Upon this Account it was thought proper, that *Charcoal* well burn'd, dried, and pulverized, should be added to them in a certain Proportion, as an excellent Thing to supply this Defect; for *Charcoal* is very susceptible of Fire, and is instantly consumed with a Flameless Heat; whence it happens that the more it is agitated by Wind or Air, the fiercer it burns till it is entirely reduced to Ashes. From the several Properties of these Ingredients we may easily perceive, that any Body compounded of them, as *Gun-powder* is, must not only be very susceptible, but also retentive of Fire, even to the Combustion of its very last Atom; for the *Sulphur* immediately catches Fire whenever applied to it, and instantly accends the *Saltpeter*, and sets Fire to the *Charcoal*, which (as I have already said) burns without any Flame, and glows with the greater Rage, the more it is agitated by the Wind or Air: The Consequence of which is, that the *Sulphur* being unable to withstand Fire, but on the contrary being instantly inflamed by it, the intense Heat of the *Charcoal* prevents the Flame of the *Sulphur* from being extinguished by the windy *Expansion* of the *Saltpeter*; therefore it continually keeps up the Flame of the *Sulphur*, and the Flame of the *Sulphur* incessantly acting upon the *Saltpeter*, they must, when they are all three duly incorporated together, produce such a Fire as is not to be extinguished, till the whole Substance of them is consumed by it, and to all Appearance annihilated. Great Care, however, is to be taken, that neither of the three be affected by any improper Accident, such as Moisture, or a disproportionate

Quantity of its Matter. Now from what we have been saying, we may conclude that the true Office and principal Business of *Sulphur*, as it is an Ingredient in *Gun-powder*, is first to conceive the Fire, and then communicate it to the two others. That the Business of *Charcoal* is to retain the Fire when once introduced, by preserving the Flame of the *Sulphur*, and preventing it from being destroyed by the *Flatulent Expansion* of the *Salt-peter*. And in short, that it is the great Business of *Salt-peter* to produce a most violent and resistless *Expansion*, and in this consists all the moving, expulsive, and active Force of *Gun-powder*; consequently *Salt-peter* is the principal Cause of the terrible Effects of it, and it must now plainly appear that the other two Ingredients are only joined with it, to put it in Action. As a Proof of this; if any one was to make a *Powder* of *Sulphur* and *Charcoal* only, and was to charge any large Piece of Cannon with it; it would be found to be so far from being able to drive out a Bullet, that it would not even dislodge a Straw: And the Reason of this Imbecility is self-evident, from what we have already said, having demonstrated that the expulsive Quality of *Gun-powder* is entirely owing to the *Expansion* of the *Salt-peter*. Upon the whole, it would be a much easier matter to contrive a *Powder* without *Sulphur* or *Charcoal*, than without *Salt-peter*: Or it would be less difficult to find two Things, the one to perform the Office of *Sulphur*, and the other to act in the same manner as *Charcoal*, than to meet with any Substance which would have such a violent Effect and such occult Qualities as *Salt-peter*.

C H A P. XXI.

Of Aurum Fulminans or Saffron of Gold----- taken from the Royal Chymistry of Ofvaldus Crolius.

*T*AKE $\frac{1}{2}$ lb of common *Aqua-fortis*, dissolve in it an Ounce of *Sal Armoniac*, or as much as a little beat can dissolve of it; thus you will have your *Aqua Regis* prepared, in which you may dissolve as much *Gold* as you please. Pour off this Solution into another *Glass*, and drop into it Drop by Drop only (because of the great Danger and Noise of its Effervescence) of the best Oil of *Tartar per Deliquium*, or for want of that take *Salt of Tartar* dissolved in common *Water*; (for you must have a good quantity of this Oil of *Tartar* ready) upon which the *Gold* will precipitate to the bottom of the *Glass*: And as soon as you shall perceive that all the *Calx* of the dissolved *Gold* is settled in the bottom of the *Glass*, (which you will easily know by the Colour of the *Aqua Regis*, which ought to be white; for if it is yellow, it will be a Sign that the *Gold* is not quite precipitated; therefore
in

in such a Case you must drop a little more of the Oil of Tartar into it; and be thou wise at my Expence :) I say; when all the Gold is fallen, you shall a few Hours afterwards pour off the Liquor that is upon it, in some warm place, and having softened the Calx three or four times with warm Water, let it be gradually dried, by a slow Fire in Balneo Mariæ; or to do it with the more safety put it into a Glass Bason, and let it dry of itself without coming near the Fire, then gather it up with a wooden Spatula, (for you must avoid using any thing made of Iron,) and put it up in an earthen Pot against you want it. Observe here, that it is very dangerous to dry it after any other Method than what I have here prescribed; for it is very apt to take Fire upon the least occasion, and breaks out into a kind of purple Smoke, and a frightful Noise not unlike that of Gun-powder, and is so universally absorbed by the Flame that there is not the least Atom of it left after its Combustion: And what is very extraordinary; if you mix a little well pulverized Sulphur with it, and burn it in a Crucible, you will have a kind of Calx very subtile, and of a brown Colour, which is entirely divested of this Fulminating Quality. But that which is the most wonderful of all is, that a Scruple of this Volatile Gold, is incomparably stronger, and acts with infinitely more Violence than half a Pound of Gun-powder. If but a Grain or two of it be put upon the point of a Knife, and beaten by the Flame of a Candle, it makes as much Noise as a Musquet, but it is a Noise which assaults the Ear with so much Violence, that the extreme Acuteness of it deafens those who are pretty near to it. The greatest difference that we find between this Powder and Gun-powder is, that the Effects of the one are diametrically opposite to the Operations of the other; inasmuch as this Thundering Powder acts by Descent, on the contrary the other by Ascent; for if (for Example) you put some Scruples of it upon an Iron Plate of moderate thickness, and set fire to it, it will infallibly pierce downwards through and through the Plate; and we may believe that the Sal Armoniac is the Cause of this odd Effect. For just as Saltpeter and Sulphur are violent Enemies to one another, as may be observed in the accending of Gun-powder, so is it with the Sal Armoniac and Oil of Tartar, whose Qualities are entirely incompatible with each other; therefore when the Sal Armoniac comes to be incorporated with the Oil of Tartar, they by the Contest of their Antipathetical Qualities, force the Gold down to the bottom, which had before been dissolved in the Aqua Regis: And thus the Oil of Tartar precipitates the perfectly pure Spirit of Nitre, which in this Conflict unites itself with the Solar Sulphur its Adversary; and because this Sulphur of the Sun is infinitely more refined, pure, and combustible than the common Sort, it produces an Effect proportionate to its superior Virtue; and this pure Nitre and Sulphur of the Sun act upon each other just as the common Sulphur and Saltpeter do. It is of this that Quercetanus and Sennertus speak in a certain passage, (according to Joh. Jonstonus Adm. Nat. Claf. IV. Cap. xxvi.) when they say, that the Effects produced by the Spirit of Nitre and Solar Sulphur proceed from the Contrariety and extreme Antipathy between them.

them. For as the Oil or Salt of Tartar is poured into the Solution of the Gold, the Salt of Tartar unites and incorporates with the common Salt, or the Allum, and the Sal Armoniac, which consequently forces the Gold downwards; and if by chance any of these Salts remain with the Gold, it must be well washed with hot Water. Thus nothing remains with the Gold but the Spirit of Nitre which is entirely incorporated with it; so that when it comes to be heated, it adheres immediately to the Sulphur of the Gold, powerfully opposes it, and rallying all its Force, is lighted and goes off with a frightful Clap.

C H A P. XXII.

Of the Preparation of Flowers of Benjamin.

TAKE a certain quantity of *Benjamin*, and put it into a Glafs Alembic or subliming Pot, covered with a Blind Head: At the same time you must have a shallow earthen Vessel with a wide Mouth, which you must set upon a Tripod, or to be the safer upon a little distilling Furnace; you shall put your Alembic or Subliming Pot into this, and encompass it well with Ashes, or else with well-washed Sand, to the height of the Matter contained in your Subliming Vessel. Then light a gentle Fire under the Earthen Pot, for fear your Alembic should be too suddenly heated, the consequence of which would be, that the *Flowers* you extract would be of a Lemon-colour or yellowish Cast, instead of being (as they ought to be) as white as Snow. As soon as you perceive the *Benjamin* to emit any Fume, continue your Fire in the same degree of Heat for a Quarter of an Hour; and as soon as you see that the *Flowers* are sublimed to the inner Surface of the Head, take it off quickly, and put another cold one on in its place, and let that which you took off cool at leisure upon a Sheet of white Paper; then with a Feather gently scrape off the fine *Flowers* which you will see sticking to the Head, and gather them carefully together. Thus you may do with the second and third Head, and so on with several others till the *Benjamin* will sublime no longer.

Another Method to the same Purpose.

Put a certain quantity of *Benjamin* into a glazed earthen Pot, and set it upon hot Ashes, and as soon as you see the *Benjamin* begin to fume, cover your Pot with a great Paper Head in form of a Cone, (as the Chymists have it, a *Cornet*) which shall be a very little wider than the Orifice of the Pot: Let it stay on for about a Quarter of an Hour. Then take it off, and scrape the *Flowers* from it; taking care to put on another

ther fresh Head immediately, which shall remain on as long as the first, then taking it off, do as before, still continuing to put on one Head after another as long as the *Benjamin* will sublime or exalt.

C H A P. XXIII.

How to prepare Camphire.

TAKE of Gum of Juniper (which is sometimes called *Sandarac*, white Varnish, or Mastich) very finely pulverized 2 lb, and as much White-wine Vinegar as will be sufficient to cover the Gum in a Phial: Bury it deep in Horse-dung for the space of 20 Days, then take it up and put it in another Glass Vessel with a wide Mouth, and expose it to the Sun for the space of a whole Month. Thus you will have your *Camphire* concreted in the Form and near Resemblance of a Crust of Bread. We have already hinted at the natural Properties of *Camphire*, but nevertheless as we make great use of it in our Compositions, I shall here treat of the Nature of it at large from the Testimony of good Authors. First, *Scaliger Exercit. CIV. 1.* speaks of it thus. *Sed ad rem arboris, lachryma est Oapura, ne bitumen credas, sicuti succinum bitumen credidisti, &c.* You must not imagine *Camphire* to be a *Bitumen* as you did with regard to *Amber*, but a Gum and the Distillation of a Tree, which falling, is transported by the Tides and Currents of the Sea to Shores where it is buried in the Sand, in which Situation it is found all along the Coast from *Memel* to *Gedan*. This will not appear strange to such as have been in those Parts, or that have ever seen the West-side of *Holland*, where great Heaps of Sand are accumulated by the Sea. *Camphire*, therefore, can be no farther deemed a *Fossil* than as it is dug up from the Sand. Those are strangely out of the way, who conclude it to be a *Bitumen* from the wretched Argument of its Combustible Nature; for we see the same Property in *Resin*, *Oil* and *Frankincense*, and such like Things. Again, he says a little farther, *Camphoram vero cum sapientum maxima pars, frigidissimam statuat, Avenrois in quinto aliam agnoscit, &c.* The English of which is: That the greatest part of the Learned have always taken *Camphire* to be cold in the very utmost Degree: But *Averroës* speaks of a sort which was only cold in the fifth Degree. For (says he) the *Indian Camphire*, which in *Arabick* is called *Coforalgent*, heats and dries in the second Degree; therefore there must have been different kinds of it, or else the Book must be erroneous, or the Opinion mistaken. At length it was questioned whether it was cold, which the Innovators denied. For truly it is very Combustible, will even burn in Water, and is very Odoriferous: But this last Property is derived from its subtile Particles, by the power of which also it burns. It contains as much Water as is necessary for it to preserve its Frigidity under that Form: but it burns because of its Oil-

ness. Sure Folly is either the Mother or Daughter of Ignorance; for who would affirm that Things which are by Nature the hottest, are also the most susceptible of Fire, since Fire has not always the most powerful Effect upon its Likeness; (I mean its Likeness with regard to Heat) but on the contrary upon such Substances, the porous Contexture of whose Parts the most readily permit it to insinuate itself. I find in the Commentaries of the Indian Observables, that the Tree is of the largest sort, spreading its Branches, and creating a Shade a great way round it. The Wood of it is very light and porous, and the † Aboali add, that it is white. The Goodness of Camphire depends upon the manner of its Extraction from the Matrix, or Place where it is formed, that is, whether it be gathered before it is expelled by Nature, or afterwards; for some of it is taken out of Veins, where it is generated like a Crust; sometimes it bursts the Rind or Bark and forces a Passage out, where it is concremented, and looks at first like Rosin, and is afterwards blanched by the Sun, or by Art. This sort is better than the first; but that is best of all, which is whitened by the Sun: It also may be done with Fire; which Operation was first performed in Imitation of Nature, by Riach: a King of that Place; from whence it has the Name of Riachina. That which is gradually distilled, is by much the purest and best, and is the most pellucid: but that which remains inclosed in the Substance of the Tree, is more gross, and of a dark Colour. There are besides these, two sorts of a baser kind. The one rough, coarse, and gummy; the other of a deep dusky Colour. It is to be adulterated or counterfeited, with Suet, Mastick and Brandy. But, says he, You may thus discover the Fraud; put some of it into the Heart of a Loaf, and set the Loaf in an hot Oven; if it liquifies, it will be good, and of the right sort; but if it dries up, you may take it for granted, that it is spurious and adulterated: They say the right sort easily evaporates. When you have that which is good, you may keep it in Marble Boxes, with Linsed, Flea-wort Seed, or Millet Seed amongst it. Jonstonus Admir. Nat. Claf. iv. Cap. ix. Scribunt Mauri Camphoram lachrymam esse arboris, &c. The Moors write, that Camphire is the Tear of a Tree, whose Branches spread abroad to that degree, as to be able to shelter an hundred Men under its Shade. They add, that the Wood of it is white and soft, and that it contains the Camphire in a light spongy Pith. But this is uncertain; it is more probable that it is got from a kind of Bitumen after this manner. The Indian Bitumen, which springs forth of the natural Camphire being put over a Fire in some covered Vessel, the finer Particles of it are sublimed by the Violence of the Heat, and adhere like fine whitish Flowers to the Cover of the Vessel; and which being collected give it that Form in which we see it. There are Merchants who affirm, that the natural sort is to be sold in India. It is so very fond of Fire, that having once conceived it, it burns as long as any of its Substance remains. It emits a bright, odoriferous Flame, which being carried up and suspended in the Air, it insensibly vanishes, which is owing to the Subtility of its Parts.

To

† A People of India so called; but according to Pliny, Abali,

To this I shall add, that it will be very easy to pulverize *Campfire* for the Use of *Artificial Fireworks*, if it be ground and pounded gently with *Sulphur* in a Mortar. The *Oil* of *Campfire*, which answers the same End, is made by adding a little *Oil* of *Sweet Almonds*, and grinding them together in a brass Mortar, with a Pestle of the same Metal, till all of it be turned into an *Oil* of a greenish Colour. Or if your *Campfire* be good, and pure, you may stop it close up in a Glass Phial, and put it into an hot Oven, where let it remain till you judge it to be thoroughly dissolved: Your *Campfire* will then yield you a fine, clear *Oil*, which will burn with admirable Sprightlines.

C H A P. XXIV.

Of Water of Sal Armoniac.

TAKE of *Sal Armoniac* ℥ij, of *Saltpeter* ℥j, pulverize them very fine, and mix them well together; then put them into an Alembic, and after having poured some of the best and strongest Vinegar you can get, upon them, distil them over a slow Fire.

C H A P. XXV.

Of a certain Artificial Water, which burns upon the Palm of the Hand without doing any Hurt.

TAKE of the *Oils* of *Naphta* or *Petrol*, and *Turpentine*, of *Quick Lime*, *Mutton Suet*, and *Hog's-Lard*, an equal Quantity of each, then beat them together till they are well incorporated; which done, distil them over hot Ashes or burning Coals.

C H A P. XXVI.

How to prepare the common Sort of Match.

LET there be first twisted some Rope, of half an Inch Diameter, made of the second Combings of Flax or Hemp, free from any of the Stalks. Then take of Ashes of *Oak*, *Asb*, *Elm*, or *Maple*, three Parts, of *Quick Lime* one Part, and make a *Lye* of it as usual; to this you shall add one Part of *Saltpeter*; and of the Juice of Horfe
or

or Ox-Dung well filtrated, and gently expressed through a Woollen Cloth, or Sieve, 2 Parts. These Ingredients being well incorporated, shall be poured upon the Rope in a Brass Cauldron, well fixed upon a Furnace; the Fire shall be at first lighted under it by slow Degrees, till it is arrived to the highest Pitch. Thus it must boil continually for the Space of two or three Days, being constantly fed with fresh Supplies of your *Lye* as fast as it is wanted, lest either your *Match* or *Cauldron* should burn. In short, your *Match* having undergone this Ebullition, you shall take it out of the Liquor, and wring it well, continually wiping off the Liquid which squeezes out of it with a Linnen Rag; and then hang it upon long Poles to dry in the Sun; after which it may be laid up in some convenient Place till wanted.

C H A P. XXVII.

How to prepare Match or Fire-Rope, which will neither smoke nor yield any ungrateful Scent.

TAKE certain Measures of fine Red or Carbuncular Sand, well washed and dried, a Layer of which you must put into an unglazed Earthen Pot, and upon that, a Layer of common *Match*; which you must coil in a Spiral Line, in such a manner, that there be the Distance of half an Inch between each Revolution of it. Over this *Stratum* of Rope, put another deep one of Sand, and upon that another *Stratum* of *Match* or *Rope* as before, and so on alternately Layer upon Layer, till you have filled the Pot, which must be covered with a Lid of the same, and well luted with Clay, that no Air may have Access to it. The whole being thus ordered, you shall encompass it with lighted Coals, in which Posture it must remain for some time: You shall then set it to cool, and being quite cold, take out the Sand and *Match*. You may also proceed in this manner in the Preparation of common Sponges, except that they must be first cut into small longish Pieces. If you take lighted Pieces of the above-mentioned *Match*, and bury them in the Ashes of *Juniper Wood*, they will burn some time without any ill Smell, and the outward Air will not consume them so fast as it does common *Match*; therefore you may hide it where you will, without fearing it will be discovered either by its Smoke or Smell.



C H A P. XXVIII.

The Manner of preparing Pyrotechnic Sponges.

TAKE of the greatest and oldest *Mushrooms*, or *Toad-stools*, that grow at the Roots of *Ash, Oak, Fir, Birch*, and other sorts of Trees; string them, and hang them up in a Chimney, where being macerated, take them and cut them in Pieces, and beat them vehemently for some time with a Wooden Mallet. This done; boil them over a slow Fire in a strong *Lye*, with a good Quantity of *Saltpeter* in it, till all the Moisture is evaporated. Then put them upon smooth Boards, and set them to dry in an Oven of moderate Heat, after which you must beat them with a Wooden Mallet as before, till they are perfectly supple and soft. Thus prepared you shall keep them in a proper Place till wanted.

C H A P. XXIX.

How to prepare several sorts of Quick Match for Artificial Fireworks.

YOU shall make *Match* of the Tow of *Flax, Hemp, or Cotton*, of two or three Strands, but moderately twisted, and put them in a new glazed Earthen Pot. Pour upon them of good *White-wine Vinegar* 4 Parts, of *Urine* 2 Parts, of *Brandy* 1 Part, of purified *Saltpeter* 1 Part, and of pulverized or meal'd *Gun-powder* 1 Part. Boil all these Ingredients together over a quick Fire, till all the Moisture is evaporated. Then strow *Flower* or *Meal* of the best *Gun-powder* you have upon a smooth large Plank, and rowl your *Match* in it; after which let it dry in the Sun or the Shade, no matter which. That which is prepared after this manner consumes very fast; but if you would have it to burn slower, you may make your *Lye* or *Liquor* weaker than we have above prescribed; and therefore you may boil it in *Vinegar* and *Saltpeter* only, then powder it over with *Flower* or *Meal* of *Gun-powder*, and let it dry as we said before.

There is another kind of *Pyrotechnic Quick Match*, which is not twisted at all, but is only boiled just as it is, in the above-mention'd Composition, or else steeped in good *Brandy* for some Hours, and then powdered over with *Flower* or *Meal* of *Gun-powder* as before, and dried. There are those

K k

who

who add a little *Gum Arabick* or *Tragacant* to the *Brandy*, particularly when they would have it stick fast to any thing.

Francis Joachim Prechtel, in the second Part of his *Pyrotechnics* Chap. II. gives an Account of a kind of *Quick Match* which is very slow in taking Fire, and in burning. He thus orders the Preparation of it. Take of *Mastich* 2 Parts, of *Colophonia* or *Fine Rosin* 1 Part, of *Wax* 1 Part, of *Saltpeter* 2 Parts, of *Charcoal* $\frac{1}{2}$ Part. Burn them to that degree, that they may be easily pulverized, and grind each of them separately into a very fine *Meal* or *Flower*. Then mixing them well together, fuse or dissolve them upon the Fire. This done, take your *Match* made either of *Flax* or *Hemp*, of a pretty tolerable thickness, and dip it into this Composition, and repeat your dipping till it has acquired the Size of an ordinary Candle. When you would use any of this, light it thoroughly at first, then blow out the Flame, that there may remain nothing but the burning Coal.

C H A P. XXX.

How to prepare Lutum Sapientiæ or Lute.

TAKE what Quantity of *Loam* you want, and dry it, beat it, and scarce it well, and with it mix some Shreds of Raw Silk, or the Sheerings of Woollen-Cloth: Upon these you must put either Horse or Ass-Dung, or Fileings of Iron; knead them well together with a sufficient Quantity of Whites of Eggs; and with this *Paste* or *Lute* you shall stop up the Glafs or Earthen Vessels you intend to put upon the Fire. You must use it whilst it is fresh and moist; for after it is dry it will be of no Use to you.

Or else take of White Chalk or Plaster 4 Parts, of common Ashes $\frac{1}{2}$ of Horse or Ass-Dung dried 1 Part, together with a little of the Fileings of Iron, and Shreds of Raw Silk. Beat them first with a Stick, then with a Shovel, or Wooden Pounder: After which, being well kneaded, they shall be put upon some firm Plank, or fixed Stone, and beaten over again, till they are sufficiently mixed and incorporated.



C H A P. XXXI.

Some Excellent and Approved Medicines and Antidotes against Burns by Gun-powder, Sulphur, Hot Iron, Melted Lead, &c.

From my own Experience.

I.

BOIL some fresh *Hog's-lard* or *Fat* in common Water, over a gentle Fire, and then expose it to the Air for 3 or 4 Nights. Put it afterwards into an Earthen Pot, and melt it over a slow Fire, and strain it through a fine Linnen Cloth, over cold Water; then wash it in clear Water till it is perfectly white, and put it into a Gally-Pot against you want it. This is for anointing the Part that is burnt as soon as possible. The Effect of it is sudden and admirable.

2.

Take of *Plantain Water*, and *Oil of Italian Nuts*, a *quantum sufficit* of each.

3.

Take of Water of *Mallows*, of *Roses*, of *Allum Plume*, a *quantum sufficit*, and mix them well together, with the White of an Egg.

4.

Make a *Lixivium* or *Lye* of pure Quick Lime and common Water; and add to it a little of the *Oils of Hempseed, Olives and Linseed*, together with some Whites of Eggs; mix them well together, and anoint the Part which is burnt with this Composition. All these Ointments cure Burns without Pain, or leaving any Scar behind; as I my self have often experienced.

Receipts taken from several others.

Take *Oil of Olives* 1 Part, of *Oil of Sweet Almonds* 1 Part, Juice of *Onions* 2 Parts, of *Liquid Varnish* 1 Part; rub the Part affected with this Composition.

If the Part happens to be blistered, or ulcerated, the following Ointment is very excellent in such a Case.

Boil a good quantity of the inner *Bark of Elder*, in *Oil of Olives*, and strain it through a Linnen Cloth; then add to it 2 Parts of *Ceruse*, of burnt *Lead*, of *Golden Litharge* 1 Part each; put them all together in a Leaden Mortar, and mix and pound them till they are reduced to a Liniment. You must take care not to break the Blisters the first or second

cond Day; but afterwards you may do it; for these Accidents are sometimes cured by Perspiration only; according to *Leonardus Bottalus de Vulneribus Sclopetorum*, Cap. xxi.

2.

Melt *Lard* into \bar{z} ij of *Water* of *Morell*, or *Garden Night-shade*, and \bar{z} j of *Oil* of *Saturn*. Mix them well together. This is a sovereign Remedy.

Or take Mucilage of *Henbane Roots*, and Flowers of *Red Poppies*, of each \bar{z} j, of *Saltpeter* \bar{z} j. Mix them together with *Oil* of *Camphire*, and make a Liniment of them according to Art.

Or take of the Juice of *Onions* roasted under hot Ashes \bar{z} ij, of *Oil* of *Walnuts* \bar{z} j. Mix them well together.

Or (if you will) take of the Leaves of *Black Ivy* 2 Handfuls, well pounded with *Plantain Water*; *Oil* of *Olives* 1 lb. Boil them all with \bar{z} iij of good *White Wine*, till all the Wine is evaporated: When the Coction is over, put as much *Wax* amongst it, as is necessary, to give it the Form and Consistence of a Liniment.

Again; take old *Lard*, melted by a Flame, and received in \bar{z} ij of the Juice of *Beet Root* and *Rue*, of the Cream of *Milk* \bar{z} j, of the Mucilage of *Quince Seed*, and *Gum Tragacant*, or *Dragant*, of each \bar{z} fs. Mix them well, and make a Liniment of them. *Josephus Quercetanus*, in *Libro Sclopetario*, tells us this is a good Remedy.

C H A P. XXXII.

Of a certain new Invention for measuring Gun-powder, Saltpeter, Sulphur and Charcoal; together with a Searce, and several other Things requisite in the Preparation of those Ingredients.

YOU will see the Form of this new-invented Instrument in *Figure 18*, the Construction of which is very simple, and you may easily order it after this manner. Make a Cylinder with a Copper Plate, and solder it well. Though its Breadth A B, and its Height A C, or B D, are arbitrary, it will nevertheless be better if you have a certain determined Dimension. In our Example, let us suppose a Cylinder that holds 4 lb of ordinary *Gun-powder*, upon which Account the Side I H of the square Instrument or Scale (which is just as long as the Cylinder is high) is divided into 4 equal Parts, each Division answering to 1 lb; we then subdivide each of them into 2 equal Parts denoting the half Pounds, and each half Pound into 2 other equal Parts, to express the Quarters, and each Quarter into 8 equal Parts to mark

mark the half Ounces. The other Side of it (*viz.*) I K, is adjusted for the weighing of Coal, and divided and marked with proper Lines and Characters. Observe here, that you cannot well divide this Side, till you know the Weight of the *Charcoal* that fills the Cylinder. For Example; if this Cylinder, that holds 4 lb of *Gun-powder*, holds only 2 lb of *Charcoal*, you must bisect the Side I K into two principal Parts, which may be subdivided in the manner we have already specified. What I have here said of *Charcoal*, must be understood with regard to *Sulphur* and *Salt-peter*, each of whose particular Divisions may be marked upon the two other Sides of the square Instrument abovementioned. This Instrument being adjusted, may be used after this manner. For Example; if you would measure 2 lb of *Powder*, lift up your square Instrument or Scale by the Ring at the end of it, till N^o 2 exactly touches the Bottom of the Cylinder, then make it fast with the Screw L, for fear it should be pressed downwards by the Weight of the *Powder*. Thus you may proceed in the Mensuration of any of the other Ingredients.

Fig. 19. is a *Searce*. Its Height is 3 Feet, its Length $3\frac{1}{2}$ Feet, and its Breadth $4\frac{1}{2}$ Feet. In the Body of this, at B, the Drawer C is contrived to go in and out, which is $\frac{1}{2}$ Foot high, $3\frac{1}{2}$ Feet long, and $2\frac{1}{2}$ Feet broad; into this Drawer, through a fine Hair *Searce* or Sieve E, falls the *Meal*, which goes down the shelving Boards in the Box A, and which you may take out with a little Wooden Ladle, made for that Purpose, in the Form as you see *Fig. E*. D is a Cross that holds the Sieve with four little Iron or Wooden Pegs or Pins, thereby making it serve with the more Convenience for sifting. G is a Goose-Wing, or the Wing of any other Bird, for sweeping the *Powder* together. H is a dry, smooth, wooden, mealing Table, which is on each Side inclosed with a Board, upon which your Ingredients for *Gun-powder* are to be ground and pulverized, or mealed. I, K, L, are Grinders, for grinding your Ingredients upon the above Table. M is another Table with a square Hole in the Middle of it at N, which is shut up close whilst the Materials are grinding and pulverizing, but opened when you would withdraw your Ingredients.





OF THE
GREAT ART
OF
ARTILLERY.

PART *the* FIRST.

BOOK III.

Of ROCKETS.



ROCKETS have always held the first Rank of the several sorts of *Fireworks*, that have been for so many Years past in Vogue. The *Latins* called them *Rocbeta*, and the *Greeks*, *Pyroboli*; which last Denomination does not strictly agree with what we understand by a *Rocket*; inasmuch as *πυροβελι* properly signifies *Tela Ignita*, or *Fiery Darts*. The *Italians* call them *Rochette* and *Raggi*; the *Germans*, *Steigende Kasten*, *Raggetten* and *Drachbetten*; the *French*, *Fuzees*; and the *Poles*, *Race*. So much for their *Names*; but as to their *Invention*, it is certainly as ancient, as the *Construction* of them is now common and familiarly known to *Pyrobolists* and *Fire-Engineers*; which, tho' it may at first Sight appear very easy and simple, yet it requires the utmost Labour and Skill to bring them to Perfection, and is the first Task enjoined to the Disciples of * *Prometheus*, who would learn the artful Management of *Fire*. And truly I think it very reasonable that this should be their first Work, inasmuch as all the sorts of *Fireworks* exhibited for the public Diversion, such as *Fire-wheels*, *Cymetars*, &c. make but an imper-

* He is fabled by the Ancients to have made Man of Clay or Earth; and to have stolen Fire from Heaven wherewith he animated the Man he had made.

fect Appearance without them. I therefore thought myself obliged in this *Third Book*, to instruct you in the due and proper Methods of preparing them; to shew you their different Forms and Construction; and to display the particular Use they are of.

CH A P. I.

Of Small and Middling Rocket-Moulds.

S O R T I.

ROCKET-MOULDS are commonly made of Brass or Lattin; or they may be turned of some hard Wood, such as Cypress, Palm-tree, Chesnut, Box, Walnut, Juniper, Wild Plumb, &c. But if you would have them formed of more valuable Materials, you may make choice of Ivory, or some fine *Indian Wood*. Workmen do not always observe the same Proportions in the Dimensions of them, no more than the same exterior Ornaments in adorning them; and in this they verifie that Proverb, which says, *As many Men, so many Minds*. I shall now give you the Proportions of small and middling *Rocket-Moulds*; (observe here that we call those *Rocket-Moulds*, small, whose interior Diameter or Orifice cannot receive a Leaden Ball or Bullet that exceeds 1 lb: the middling Sort, are such whose Diameters can admit Bullets from 1 lb to 2 lb, or 3 lb at the farthest: and those are called great *Moulds*, whose Diameters can admit of Balls from 2 lb to 100 lb.) as to the *Moulds* of the larger Sort, I shall speak of them in the following Chapter. The first *Mould* then is after this Fashion. In *Fig. 20.* I suppose that the interior Diameter of the *Mould* (*viz.*) A, B, is equal to the Diameter of a Leaden Bullet of 1 lb; and that the Height of the *Mould* from Y to E, is 7 of the aforesaid Diameter; and that from E to G is the Height of the Breech or Bottom, which stops up the *Mould* whilst the *Rocket* is driving; which is $1\frac{1}{2}$ Diameter. You must here take Notice, that it is the common Practice of *Pyrobolists* to measure the hollow Cylinders or Orifices of *Rocket-Moulds* by the Diameters of Leaden Balls. To return then to our Subject: upon the Bottom you have a solid Cylinder whose Diameter is C, D, or $\frac{2}{3}$ of its Height, which is 1 Diameter of the Orifice: This Cylinder is crowned with the Hemisphere or Half-Bullet L O P M of $\frac{2}{3}$ of the same Diameter. As to the Ornaments in general, they must be left to every one's particular Fancy; but we most commonly affect an Imitation of the Columns of Architecture. In our *Figure* the Height of the Capital is one Diameter. Now to form the several Members of it; this same Diameter being set off from Y towards G, upon the Line Y, G, you shall trisect it into 3 equal Parts; each of which

which shall be subdivided into other smaller Parts. Moreover from F to K you shall set off one Diameter for the Members of the Base. I shall be more particular upon this Head when I come to the Explanation of the following *Figure*, which is more artfully wrought, and more adorned than this: But in the mean time you may take all the Proportions of this with a pair of Compasses. The Thickness of the *Mould* from A to W, and from B to X, as likewise from S to Z; and from A to R, and then down to T and U, is $1\frac{1}{2}$ a Diameter of the Orifice of the *Mould*; but from F to C it is a whole Diameter, and in short from G to H it is 3 of the same Diameter. I is an Iron Pin that runs through the Substance of the *Mould*, and through the Cylinder upon the Bottom, to keep them together whilst the *Rocket* is driving.

S O R T II.

Fig. 21. In *Fig. 21.* the Height of the whole *Mould* G, E, is 9 of the Diameter A, B, two of which are taken up by the Bottom. A, B, C, D, is the Hollow of the whole *Mould*. A, N, or G, L, is the Height of the Capital of it, and is $1\frac{1}{2}$ of the Diameter A, B. Now this Diameter being divided into 80 equal Parts, it will expedite our taking the Proportions of all the particular Members of the Capital. First then, in going downwards, the Sloping Cornish shall be 7 Parts high; the Lift of it 3; the Echinus reversed 7; the Lift of that 3; the Cymatium or Doric Gule-revers'd 7; the Lift of it 3; the upper Band 10; the Face 10; and the nether Band 10 also; the Reglet 2; the Apophyge 10; the upper Ring 2; the Astragal 4; and the nether Ring or Neck of the Column 2: the Projectures of one and the other Lift or Fillet is 5 Parts; as is also the Retreat of the Face. The half Diameter of the Doric Gula shall be taken upon the Perpendicular of the Face, and upon the Reglet that is under it; but the Semi-Diameter of the reversed Echinus, shall be taken upon the Perpendicular, that descends from K upon A, G; as for A, K, it shall be 30 Parts of the Diameter. The Semi-Diameter of the nether Echinus answers to its own Height. The right Line U, F, terminates the Projecture of the Lifts or Rings on one Side, and the Line I, E, on the other; but that would be increased if from B and U, and A and I you allow 60 Parts of the Diameter. Know also that these right Lines determine the lower Part, or Base and Pedestal of the *Mould*. The upper Thickness of the *Mould* as far as the Astragal is $\frac{1}{2}$ a Diameter of the Orifice or 40 Parts, but the Lower Thickness of O, P, upon the Base is 50 of the same. All the Thickness of the Middle or Shaft of the *Mould* is terminated by the right Line M, O, but the Thickness of the Base by that other Line E, W, upon E, I; the whole Base is $1\frac{1}{2}$ Diameter in Height. Let us now speak of the several Members going upwards: First then, the Plynth is 110 Parts high; the little Echinus reversed 8; the Lift under it 2; the Doric Cymatium 6; the Reglet 2; the

BOOK III. *Of the Great Art of ARTILLERY.*

133

the Tore 6; the Liftel 2; the Projecture of the Lifts, and the Semi-Diameters of the Echinus reverfed, and Doric Cymatium, answer to their respective Heights. The Members of the Pedestal are the little Tore which is 3 Parts, and the Reglet but two Parts only. The Diameter of this (*viz.*) E, F, is 3 of the Diameter aforesaid. The Cylinder C, Q, R, D, upon the Pedestal is one Diameter in Height, and its Thicknes Q, R, is 78 Parts of the same Diameter: The Diameter of the Hemisphere upon the Cylinder is $\frac{1}{4}$ of the Diameter of the *Mould*, and consequently 60 Parts of it. This is what I have to say of the lesser *Rocket-Moulds*, as well of the least as the middling Sorts. If therefore you would succeed in your Attempts in this kind of Work, you must take care nicely to observe the Proportions we have laid down; but indeed the outward Embellishments may (as we have already said) be alter'd, and varied according to the Fancy of the Person who makes them. Besides these two Figures, I present you a third (*viz.*) Fig. 22. by means of which we may determine Fig. 22. the proper Dimensions and Ornaments of great *Rocket-Moulds*; and from thence find the due Proportions of those of lesser Sizes. That which I have given in this *Figure* is but of one *Loth* or half Ounce; and from thence we may find out *Moulds* for the $\frac{1}{2}$, $\frac{1}{3}$, $\frac{1}{4}$, $\frac{1}{5}$ Part of a *Loth* after this manner. The Base of the *Figure* A B, is divided according to a Cubical *Ratio*, and upon the Points of Division you have Perpendiculars erected, which are terminated by the Secant C, D, which must be produced from C to D; provided that B C, which is the Height of a *Mould* of one *Loth*, be 9 Diameters of its Orifice or hollow Cylinder; and then all the Perpendiculars may be drawn of the same Proportion as to Height.

Observe here that the Semi-Diameters or *Radii* of the Quadrants, and the Lines produced to the Extremities of them, in the *Figure* of the *Mould* of one *Loth*, denote the Thicknes of the *Mould* in the Places where their Centers are situated. To conclude; what we have here said concerning the Proportions of small *Rocket-Moulds* found out by means of a larger, may be inverted; and you may reciprocally have the Proportions of large *Moulds* by means of one of the smaller sort.

C H A P. II.

Of great Rocket-Moulds.

WE have in the foregoing *Chapter* limited the Proportions of small and middling *Rocket-Moulds*; having allowed them 7 Diameters of their hollow Cylinders without reckoning the Bottom: And it must not be wondered that I have taken this Liberty; my continual Experience, and the most valuable part of my Life which has been devoted

to this kind of Study, having sufficiently confirmed my Practice, and convinced me that they neither can nor ought to be made otherwise, if you would have them to answer as they should: And the Authority of the most modern *Pyrotechnists* will support me in what I have laid down; for to speak my Mind, it is in vain for you to seek after these nice Proportions in the Writings of the Ancients; for if you compare them all together (I assure you, I have now before me at least a couple of Dozen of Authors who have written on *Pyrotechnics*.) you will find them not only widely different from one another, but likewise entirely contrary to my Observations, and (if I may so say) Diametrically opposite to my Practice. But be this as it will, I shall give you some of their Rules and Directions to confirm my Assertion. First then; *Brechtelius* in the second Part of his *Pyrotechnics* Chap. IX. saith, 'That the *Mould* of a *Rocket* of one lb, ought to be the Height of 2 Fingers, and the Diameter of its hollow Cylinder the Breadth of two of the same. Here the Diameter and Height are in a Subquadruple Proportion to one another; but he increases his *Moulds* by adding successively $\frac{1}{4}$ of a Finger both to their Breadth and Height. From this Progression this confused Disproportion will arise, That a *Rocket-Mould* of 17 lb will have its Diameter in a † subduple Proportion to its Height; and the Diameter of one of 100 lb will be within a little more than $\frac{1}{2}$ of its Height: Thus the Diameter and Height will be to one another as 106 is to 131; but as this Number is a Surd, it cannot be reduced to the lowest Term. However the Height will be to the Diameter in a superpartient Proportion or as 1, $\frac{25}{106}$ Parts. You must here again observe that the Diameters of his *Moulds* are not increased in a Cubical Ratio as they ought to be, but by an uniform Progression (namely) by the Addition of $\frac{1}{4}$ of a Finger; and that the Heights of his *Moulds* are most sadly proportioned to their Diameters: Upon the whole, I am persuaded that this *good Man* never made any *Rockets* in his Days, that exceeded one or two lb; for it would have been impossible for him to make such ill-contrived Things depart, or oblige them to mount up, they being almost as broad as they were long. This is not the least Defect when he says, that the Diameter of a *Mould* of one lb ought to be 2 Fingers; for it being certain that 2 Fingers exactly constitute the Diameter of an Iron Bullet weighing one lb of *Noremberg*; it will follow, that the Diameter of a *Mould* of 100 lb will according to his reckoning be 26 Fingers and $\frac{1}{2}$. Now if we suppose this Diameter to be that of an Iron Bullet, it ought to weigh 2326 lb 3 Ounces: But if we suppose it to be the Diameter of a Leaden one (in pursuance to the present Practice, as I before hinted) such a Bullet should weigh 3350 lb 13 Ounces. By this, any one may readily perceive the wretched Mistakes *Brechtelius* has fallen into, and how absurdly he reasoned upon this Head; and consequently take care not to mind what he

† This is right. The *French* has it Subdecuple, which is impossible.

teaches. *Johannes Schmidlapius* is the second of those ancient *Pyrobolists* I shall mention, who lived some time before *Brechtelius*. He would have the *Moulds* of all *Rockets* be the Height of 6 Diameters of their Orifices; as for the Diameters themselves he increases them after this manner. He divides the Diameter of the first *Mould* into five Parts (which he supposes in his Figure to be equal to that of a *Loth* or half Ounce of Lead) and adds two of those Parts to the first Diameter to constitute that of the second *Mould*. This is the Order he observes in the Construction of *Moulds ad Infinitum*. But to speak my Mind as to this Matter; he allows too great a Height to his larger *Moulds*, and has assigned no certain fixed Measure for the Diameters agreeing with the Diameters of Leaden or Iron Bullets. However I have often tried, and found that Diameters increased after the manner he prescribes, observe the following Progression with regard to Leaden Bullets; (namely) the second Diameter containing $\frac{7}{3}$ of the first, is exactly the Diameter of a Leaden Bullet of 3 *Loths*: The Third containing $\frac{7}{3}$ of the second Diameter answers to that of a Leaden Bullet of 7 *Loths*; the Fourth of $\frac{7}{3}$ of the third Diameter is equal to the Diameter of a Leaden Ball of 20 *Loths*: The Fifth containing $\frac{7}{3}$ of the fourth Diameter is equal to that of a Leaden Bullet of one lb 22 *Loths*: The Sixth $\frac{7}{3}$ of the fifth Diameter is equal to the Diameter of a Leaden Ball of 4 lb 26 *Loths*: The Seventh $\frac{7}{3}$ of the Sixth, to the Diameter of a Leaden Bullet of 13 lb: The Eighth $\frac{7}{3}$ of the Seventh, is the Diameter of a Leaden Ball of 35 lb: And to conclude; the Ninth $\frac{7}{3}$ of the Eighth is equal to the Diameter of a Leaden Bullet of 98 lb. From what I have here been saying, it follows, that this Author has not ascertained any fix'd or limited Proportion to increase the Diameters. But this is pretty excusable, and we do not condemn him entirely; inasmuch as he has taken upon him to shew us, how to make *Rockets* of such Sizes, that a small one may exactly fill up the Hollow of a larger. This may be easily conceived; for if (for Example) you take the Diameters of 9 *Rockets*, beginning from one *Loth*, to such a Number of Pounds as we have specified above; the Eight First being put into one another, they will all very conveniently go into the ninth and last *Rocket*, the Diameter of whose Orifice is equal to that of a Leaden Ball of 98 lb: But you must take care that the Paper of your small Cases, and the Wood of the great ones do not exceed $\frac{1}{3}$ of their respective Diameters. These two *Pyrobolists* I have now been speaking of, are the most ancient I can recollect; the first having printed his *Pyroboly* about 59 Years ago; and the other published his about 90 Years since. Amongst those of the latest Date, we find *Diegus Ufanus*. This Author, in Chap. XXVI. of the third Treatise of his *Artillery*, determines the Heights of little and big *Rockets* to be 6 or $7\frac{1}{3}$ of their Diameters: Therefore in this, he comes pretty near to the Proportions of our small *Rockets*; but differs widely from our Rules with regard to Great ones. But the most modern and most excellent *Py-*
robolift

robolift of all those I ever read (without disparaging *Adrian Roman*, *James Valbaufe*, *Furtenbach*, *Frantsbergue*, and several other worthy Persons, who have treated learnedly on this Subject) is one called *Hanzelletus Gallus*, who by his Name should be a *Frenchman*: This Author makes the *Moulds* of all his *Rockets* from one *Lotb* to 6 *lb* to be 6 Diameters, and it is in this that he disagrees the most from us: But as for great *Rockets* (in which consists the whole Secret of the Art) he says, it is sufficient if they be 4, $4\frac{1}{2}$, or 5 Diameters in Height; here he approaches very near to our Proportions. As for our Observations on the Construction of great *Rockets*, we here present you with a *Mould* (Fig. 23.) calculated for the making those of 20 *lb*, I having supposed the Diameter of the hollow Cylinder A, B, to answer to the Diameter of a Leaden Bullet of that Weight. The Height A, C, or B, D, is $6\frac{7}{100}$ Diameters: And is taken from the following *Table*, where 86 corresponds exactly with 20 *lb*; that is, that the Diameter A, B, being first divided into 100 equal Parts, 86 of them were taken off by the Compasses, and repeated 7 times from A or B, towards C or D, to constitute the Height of the *Mould* A C, or B D. For as the Diameter composed of 100 equal Parts being 7 times repeated gives the Height of *Rocket-Moulds* of one *lb*, so 86 being 7 times repeated gives the Height of a *Mould* that is $6\frac{7}{100}$ of its Diameters. Thus you may find the Heights of all *Moulds* whose Diameters answer to the Diameters of Leaden Balls as far as 100 *lb*. But if you would have them by the Rule of Three, say, as 100 is to 7, so is the Number over-against your Number of Pounds in the following *Table* to a fourth Number. Or you may divide the Diameters of the hollow Cylinders of the *Moulds* into 100 equal Parts, and take as many Parts from that Number, as answer to the Number in the *Table* opposite to the Number of Pounds answering nearest to the Diameter of your *Mould*; a sevenfold Repetition of which will give the due Height of the *Mould* you would make. The same it is with the Diameter of a *Mould* of 100 *lb*, which if it be divided into 100 equal Parts, and with a pair of Compasses you take † 57 of those Parts; a sevenfold Repetition of them will give the Height of a *Rocket-Mould* of 100 *lb*, and which will be 4 of its own Diameter minus $\frac{7}{100}$ or 399 of such Parts as its Diameter is divided into.

From hence it is evident that I have not fallen into an Extreme of too much nor too little with regard to these Proportions; for I have neither increased the Heights of *Moulds* by an uniform Progression after the

† Example: as 100 : 7 :: 57

$$\frac{100 \overline{) 399}}{3} = 3 \frac{99}{100} = 400 - \frac{7}{100} = 399 \text{ Divisions of the Diameter.}$$

manner

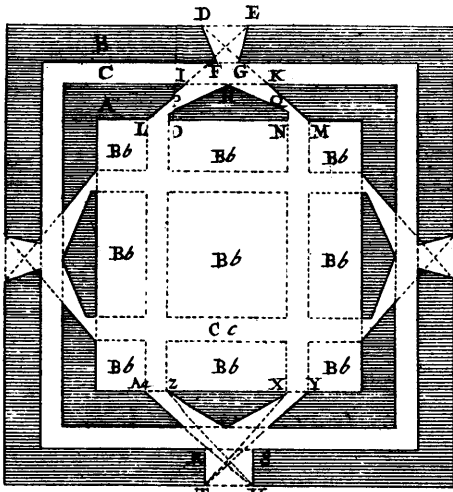

Fig. 17.

A Scale of 30 Feet

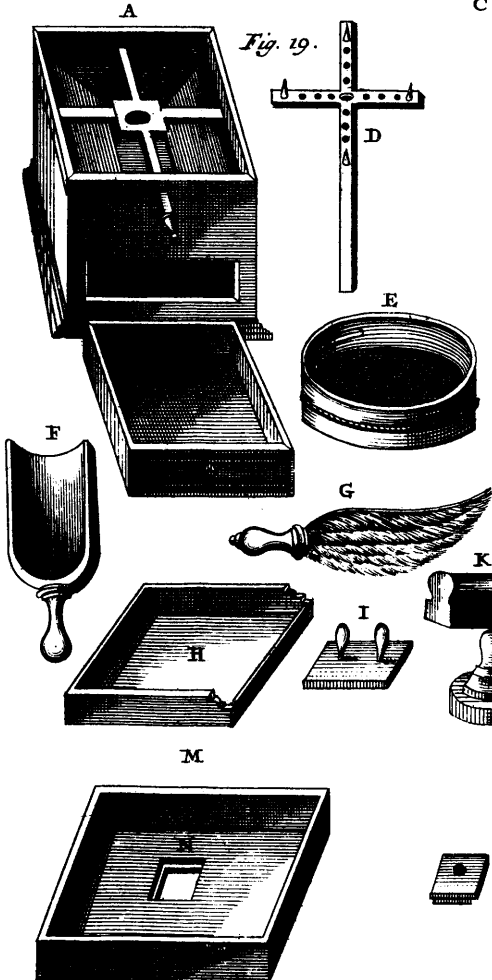

Fig. 19.

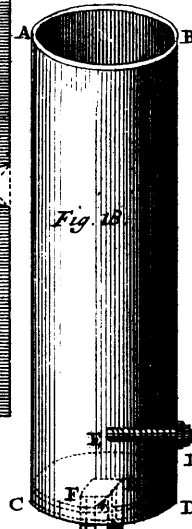

Fig. 20.

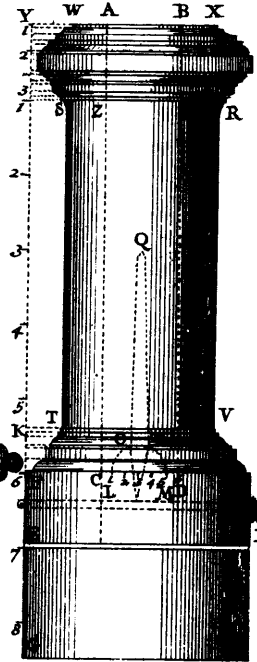

Fig. 21.

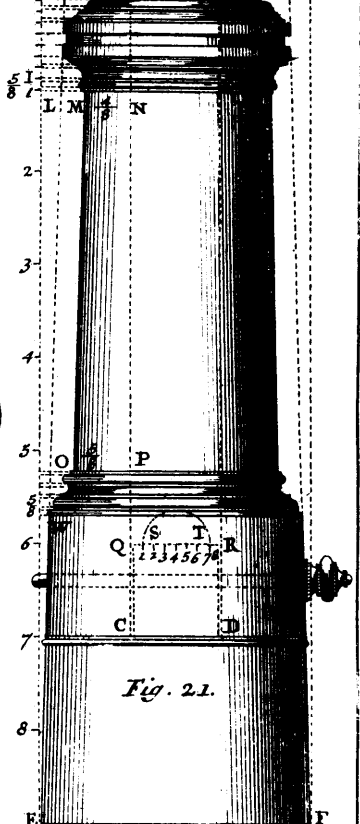

Fig. 22.

manner of *Brechtelius*, nor laid down one universal Dimension of Height with respect to the several Diameters; nor always kept to 6 and $6\frac{1}{2}$ Diameters, like *Diegus Ufanus* and *Schmidlapius*. Upon the whole, I have not augmented the Diameters according to the Methods of *Schmidlapius* and *Brechtelius*, by dividing them into 5 Parts, and adding 2 of the like Parts to them to constitute the Diameter of the subsequent *Mould*, nor by adding $\frac{1}{4}$ of a *Finger*, as they have done; but I have decreased the Heights of *Moulds* proportionably to the Increase of their Diameters in a Cubical *Ratio*; so that I believe no one can tax me with having committed a Mistake upon this Head.

Now that you may have no manner of doubt upon you with relation to what I have just been saying, I here-under present you with a little *Table*; which has not been calculated so much by Theory and Speculation, as confirmed and ascertained by my long Practice; which, together with the many Losses I have sustained, and the daily Expences I have been at in my Prosecution of this Study and Art, gave Life to my Invention.

A TABLE of Heights for great Rocket-Moulds.

Pound Weights of Leaden Bullets whose Diameters answer to the Diameters of <i>Rocket-Moulds</i> .	Hundredth Parts of Diameters in a subseptuple Proportion to the Heights of <i>Moulds</i> .
1	100
2	98
4	96
6	94
8	92
10	91
12	90
15	88
20	86
25	84
30	82
35	80
40	78
45	77
50	75
55	73
60	71
65	69
70	67
75	66
80	64
85	62
90	61
95	59
100	57

Fig. 23. This is not enough : Let us return again to our *Figure*, and we shall find still something farther relating to this Proportion of *Moulds*. E X then, is the Height of the Base of one Diameter of the Orifice or hollow Cylinder : X, C, is the Thickness of the *Mould* throughout, which is $\frac{1}{7}$ of the same Diameter ; E, F, is the Solidity of the Base or Bottom equal to $1\frac{1}{7}$ of the aforesaid Diameter ; B, P, or A, P, is the Capital of the *Mould* whose Members are reversed or go upwards : The Lift is $\frac{4}{7}$ of the Diameter in Height ; the Echinus reversed $\frac{1}{7}$; the Reglet is $\frac{1}{7}$; and in short, the sloping or inclining Cornice is $\frac{1}{7}$. Q Q shew the Thickness of the Substance of the *Mould* ; P P denote the Hollowings wrought in it, which must be wouled, or securely girt round with glued Cord, to prevent the *Mould* from splitting whilst you drive the *Rocket* : These Hollowings are $\frac{1}{7}$ Diameter deep. Besides this, there is a Wooden Cylinder joining to the Bottom, which is the Height of one Diameter ; but this Dimension for it will not always obtain ; for in great *Rocket-Moulds* from 40 to 70 lb, it must be but $\frac{2}{3}$ of a Diameter, and in the rest till you come to 100 lb, it must be but $\frac{1}{2}$ Diameter. This Cylinder must be crowned with an Hemisphere, or half Bullet, whose Circumference is described from the Center N, and whose Diameter is equal to $\frac{2}{3}$ of a Diameter of the Orifice or hollow Cylinder aforesaid. R, is a small Cavity where a Ring of some Metal is commonly fastened. W, is an Iron Pin that keeps the upper and under Part of the *Mould* together. As to any thing else, that may be farther remarkable in this Figure, we shall speak of it in the next Chapter.

Fig. 24. In Fig. 24. you have a *Mould* for the Construction of Paper *Petards* (in *English*, *Crackers*) which I shall shew you how to adjust, and make use of in the subsequent Chapters. I would only have you observe here that the Height of these *Moulds*, which is A, B, C, D, ought to be 4 Diameters of their hollow Cylinders, and that the Height of the Bottom I, K, and of the solid Cylinder G, E, or H F, is one Diameter ; in short, the upper Surface of this Cylinder, E F, must be a perfect Plane, except where it is heightened by the Hemisphere.

C H A P. III.

Of several Instruments for Making, Choaking and Driving all Sorts of Rockets.

YOUR *Rocket-Moulds* being thus adjusted, according to the Proportions laid down in the foregoing Chapters, it will be necessary that you be provided with several other Utensils for carrying on your Work. In the first Place then ; for small and middling *Rockets* you must have a
 Wooden

Wooden Cylindrical *Driver* or *Rowler* (for very small ones we use a little Iron Rod) whose Length shall be equal to the Height of the *Mould*, and its Thickness $\frac{5}{8}$ of the hollow Cylinder. See the Representation of it in *Fig. 25*, where the Line A B is the Length of 7 Diameters of the hollow Cylinder of the *Mould* of the second Model in *Fig. 21*. the lower end of it terminates in an Hemisphere, whose *Semi-Diameter* is $\frac{1}{4}$ of the Diameter of the hollow Cylinder (for it is proper this *Rowler* or *Former* should be a little longer than the Height of the *Mould*) and the Thickness of it C D, is $\frac{5}{8}$ of the same Diameter. E is the Handle of it, which ought to be a Hand's breadth in Length. Upon this *Rowler* or *Former* you shall paste or glue together, as nicely as you can, some good strong Paper, till by the several Turns of it your Case has acquired the Thickness of $\frac{1}{2}$ of the Diameter aforesaid; notwithstanding that in the first *Mould*, *Fig. 20*, I have supposed this same Thickness to be $\frac{1}{3}$ of the Diameter; for then it is necessary that this *Rowler* or *Former* should be $\frac{2}{3}$ of the Diameter. But for great *Rockets* that are made of Wood, such as you see in I K *Fig. 23*, the Thickness K B, or A I is $\frac{1}{2}$ of the Diameter, or a very little less; for there is always a small Space, as S, left between the Concavity of the *Mould*, and the Convexity of the *Rocket*, that there may be room for a pretty substantial Wounding of strong Thread or Cord, with which the Outside of the *Rocket* is commonly reinforced. The Neck or lower Part, G O, of the *Rocket* in the same Figure is $\frac{1}{3}$ of a Diameter. Now if your *Rockets* are made of Wood, you cannot use the *Driver* or *Rowler* I have been describing above, which is designed only for Paper or Canvas *Rockets*; but for Wood it must be $\frac{2}{3}$ of a Diameter, and its Length shall be equal to the Height of the *Mould*, minus the Height of the Cylinder upon the Bottom. Upon such a *Rowler* or *Former* I have made Paper and Canvas *Cases* for *Rockets* of 20 or 30 lb and upwards, and after having woulded and secured them round with glued Packthread, I have put them into the Nave of a Cannon Wheel, and having encompassed them firmly with dry Sand, and fastened them with Coins, and fixed a Bottom under them, I have in that posture driven them very conveniently.

Secondly, you must have a *Rammer* or *Driver* different from this, for charging your *Rockets*, which may be constructed two several ways; for if you intend to bore your *Rockets* after they are driven, (as we shall hereafter observe) you shall give it the Form you see represented in *Fig. 26*. Its Length A B, shall be equal to the Height of the *Mould*, and its Thickness B C shall be minus $\frac{1}{12}$ equal to the *Axis* C, D, in the first *Figure*, and shall be perfectly smooth and round, that it may the more conveniently drive or ram the Composition, and consolidate it in the *Case* or *Coffin*. But if you would drive your *Rockets* upon Copper or Iron Needles or Piercers, such as O P Q, and L M H, in *Fig. 20*. and *Fig. 23*, your *Driver* or *Rammer* shall be of the very same Dimensions with the Hollow of your *Rocket-Case*, or *Coffin*, and shall have a Cavity in it

that exactly fits the Piercer or Needle; to the end that when you drive your *Rockets* the Needle may have free Access into the *Driver*, and that consequently the Composition may be driven and compacted in a firm Body all round it. You must here observe, that if the Needle is fixed in the Bottom of the *Mould* (which it must of necessity be, if you would have it in a perpendicular Position, and exactly in the middle of the *Rocket*, upon which much depends) you must have another Bottom without a Needle for adjusting the Paper Cases, and a *Driver* or *Rammer* according to the first Model; or a hollow *Driver*, as we said before.

Fig. 27. In Fig. 27. (for Example) B A, is the Length of the *Driver* equal to the

Fig. 23. Height of the hollow Cylinder of the *Rocket* represented in Fig. 23. its Breadth B C, is equal to the Diameter of it, or a little less, as we have already said: And D, F, E, is the Hollow that receives the Needle.

Besides these two *Rammers* or *Drifts*, *Pyrobolists* have a Third equally necessary for driving *Rockets* upon Needles. You may see the Form

Fig. 28. of this in Fig. 28. where its Length A B is equal to the Height of the *Rocket* above the Point of the Needle; that is, from L to I K the Mouth

Fig. 23. of the *Rocket-Case* or *Coffin* in Fig. 23. but its Breadth or Thickness B C, is exactly equal to that of the first *Driver*. This is for driving the solid Part or the *Head* of the Composition in the *Rocket*; and the Handles D and G shall be fashioned as you see in the *Figures*: The Ends H and E shall have Brass Rings round them, especially when designed for the use of great *Rockets*, to prevent their spreading or splitting by the Violence of the Driving.

Fig. 29. Fig. 29. represents a Leather Belt or Thong, with its Buckle, Copper Ring, and Iron Hook moveable to and fro upon the Belt. It is with this that the *Pyrobolist* girds himself when he would choak his *Rockets*.

Fig. 30. Fig. 30. you have another Hook with a Screw, which being screwed into any Tree, or piece of Wood firmly fixed in a Building or otherwise, serves together with the First, to draw the Cord which is about the

Fig. 31. Neck of the *Case* after the manner that you see in Fig. 31. Fig. 32. represents the Cord, and Fig. 33. is a Wooden Taper-bit for opening the

Fig. 32.
and 33.

Orifice, when the Neck is choaked too close.

We have another Way of choaking middling *Rockets* (*viz.*) by a Wooden Sheave or Shiver turning upon an Iron Pin or *Axis*, over which is a Cord, one End of which is fastened to an Iron Ring, and the other to the End of a Treading Board or Treadle, upon which the *Pyrobolist*

Fig. 34. presses with his Foot, as may be seen in Fig. 34.

Fig. 35. But for the choaking of great *Rockets*, you may use the Contrivance in Fig. 35. with its endless Screw, and Handle to turn it (A) together with its Hook and Iron Ring to which the Cord is tied to choak the *Rocket*, after having put into the Neck of it a Cylinder done round with Hair or

Fig. 36. Wool, and crowned with an Hemisphere as may be seen in Fig. 36. which serves properly for forming a round Cavity in the Neck of

the

the *Rocket*. *Fig. 37* is sometimes used to the same purpose; it being *Fig. 37.* an Iron *Instrument* with Hollows cut on each Side of it, into which you put the Necks of your *Rockets*, in order to compress or *choak* them. There are other ways of *choaking* *Rockets*, besides those I have mentioned. As for Example; you may fasten any Handspike or Lever to any Wall, Pillar, or Rafter, and then pull upon the *Choaker* either by a great Force or Weight. But as these Ways are out of Use, and awkward in themselves, I shall pass them over, and proceed to a Description of such *Instruments* and Things as are more necessary for us to be acquainted with.

Fig. 38 represents a *Copper Plate* for making a *Charger*, as you see *Fig. 39.* in *Fig. 40.* I have given it such Proportion, that its Length from A to *Fig. 40.* B is $1 \frac{1}{2}$; Diameter of the hollow Cylinder of the *Rocket*; and its Breadth C D equal to 2 of the same Diameter; and have ordered it so, as to terminate in a Semi-Circle at the charging End, and have to its Length and Breadth added another Diameter respectively, that it may be conveniently fitted to a little Wooden Cylinder or Handle to which it may be fastened with small Nails; for let the Thickness of the Handle be equal to one Diameter, and the Rotundity of its Convex Surface will be 3 Diameters, that is, equal to the Breadth E F. The Length I have assigned for this *Plate*, ought to be observed in making *Chargers* for little and middling *Rockets*; for I have often experimented, that *Chargers* made in this Proportion contain exactly such a quantity of Composition whose Height fills one Diameter of the hollow Cylinder of the *Rocket*. Now it will be sufficient, if you put in as much Composition at a time as being well driven with a Wooden Mallet will take up the Space of half a Diameter aforesaid. But in driving of great *Rockets* you must put in less Composition at a time; for it will be sufficient if you put in half of what we have directed with respect to small *Rockets*; and consequently the *Plate* with which you would make a *Charger*, that should hold but just so much Composition as to fill up half the Space we have been mentioning of the hollow Cylinder of a great *Rocket*, and which being well driven should be only $\frac{1}{2}$ of a Diameter in Height, should have its Length equal to but one Diameter. As for the Size of the Handle to which the *Plate* is to be fitted, it shall be in such Proportion as we have above directed.

In *Fig. 39* you have the Representation of a Wooden *Mallet* with *Fig. 39.* its Handle. It should be made of some hard, heavy Wood, such as Elm or Birch Root; its Length or Height shall be $1 \frac{1}{2}$ of its Breadth or Thickness, which shall be proportioned to the hollow Cylinders of *Moulds* after this manner. From 100 lb down to 50 lb, your *Rockets* shall be driven with *Mallets*, the Diameters of whose Thickness are equal to the Diameters of the hollow Cylinders of the *Moulds*: But all other *Rockets* down to 10 lb, with a *Mallet* whose Diameter is equal to that of a Leaden Bullet of 50 lb. In short, all from 10 lb to 1 lb, shall

be driven with a *Mallet* whose Diameter is equal to that of a Leaden Bullet of 40 lb; and as for those from 1 lb to 8 *Lotbs* or 4 *Ounces*, they shall be driven with a *Mallet* whose Diameter is equal to that of a Leaden Bullet of 20 lb. Or to do better, and speak more plainly; all your *Mallets* from 100 lb to 10 lb shall have their Diameters equal to the Diameters of the Orifices of their respective *Moulds*; which done, you shall make a Cavity in the Ends of them which you do not strike with, into which you must pour as much melted Lead as may be sufficient to make them as heavy as the Bullets by whose Diameters the Orifices of their respective *Moulds* are measured. We may with a *Mallet* of 10 lb drive all other *Rockets*, down to 4 lb; and from 4 lb to 1 lb with a *Mallet* of 6 lb; and from one lb to lb fs with a *Mallet* of 4 lb. In short, from lb fs to 4 *Lotbs*, or 2 *Ounces*, the *Mallet* shall weigh 2 lb.

As for the driving of very small *Rockets*, or (as we call them in English) *Squibs*, you need not be so nice in the Preparation of them. I have known some modern *Pyroballists* who assigned a determinate Number of Strokes, and *Mallets* of various Weights, for the several Compositions they used in driving a *Rocket* of any one particular Size; so that they changed the Weight of their *Mallet*, and varied the Number of Strokes, according to what Composition they used. But in my Opinion this Rule is more ridiculous and whimsical, than useful; therefore setting these Absurdities aside, this is the most certain and best Method that can be pursued with regard to this Matter; (namely) When you pour Composition into your *Rockets*, it shall not be too dry, for fear of its dispersing, and flying about in a subtle Meal or Dust whilst you are driving it; but shall be a little moist, to the end that it may collect the better, and be the more solidly compressed in the Case or Coffin of the *Rocket*. You may believe, it is impossible to ascertain any determinate Number of Strokes that may be exactly sufficient in driving it; and therefore we can only say that the Composition ought to be driven and beaten till it is become as hard as a Stone. As for those Particles that are dried by the Violence of the driving, and will not unite with the rest; they shall from time to time be turned out, by stooping the *Mould*, and striking it briskly to make them fly abroad. I must farther caution you, to strike the *Driver* with an equal Number of Strokes, as often as you pour your Composition into the Case; and let your Blows be given with an uniform Force, neither too violently nor too gently, but with moderation, and making a short Pause after each Blow. The Weight of the *Mallet* shall be as we have ordered above. The Compositions shall be taken and used in Proportion to the Diameters of *Rockets*, as we shall observe in the following Chapter; and beware of using an hundred different Sorts of Compositions, for one or any particular sized *Rocket*, and only stick to one or two, which you shall by Experience find to be the best. To this I shall add, that such Ingredients as are too dry, imperfectly mealed, and negligently searced, or
I that

that have too much Charcoal amongst them made of any hard, gross Wood, cannot be consolidated without a great deal of Labour, and therefore must be driven much longer than those which are free from these Defects. I must furthermore inform you that the stronger the Composition is, so much the more ought it to be driven; that the Fire may meet with the more Obstruction in consuming it, and that by means of its solid Consistence the Action of that Element may be restrained. But this, on the other hand, is apt to throw us into a great Inconveniency; for the Violence of the driving greatly adds to the Strength of the Composition, and indues it with I know not what extraordinary Virtue which it had not before; therefore must you keep this Sentence in Mind, as a general Rule to be observed in our Art (namely) *Serva Mediocritatem*: Avoid Extreame, and keep in the middle Path, lest by running into either Excess, your Labour proves vain and abortive. But let us have done with this Digression, and resume our Subject. Say we then, that the longer the Handle of the *Mallet* is, and the higher the *Pyroballist* lifts up his Arm to strike, with so much the more Velocity and Power will the *Mallet* fall upon the Head of the *Driver* that is beneath. So that a *Mallet* of 10 lb only will act much more violently, and descend with greater Force, than one of double that Weight, but whose Handle is only Subdecuple of the First. If you would know the Cause of this, consult the *Mechanics*, and they will satisfy you. There are those who imagine that all Bodies that are put in Action by any means whatsoever, act with the more Power upon the Bodies they impinge, the denser the Air is between them: For (say they) it is certain that the Air is condensed in Proportion to the Velocity of the descending or acting Body; and all such as move in a Circle (I speak of this circular Motion only) have their Motion the more swift, the farther they are removed from their Center of Motion; so that the Velocities of Bodies in this case, are to one another respectively, as the *Radii* of the Circles, and the Circumferences they describe. If now you take the Handle of a *Mallet* that is somewhat long for the *Radius* of a Circle, the Center of which is supposed to be in the Arm of him that strikes; "This *Mallet* will move more freely, and with greater Velocity and Power, than another *Mallet*, whose Handle is shorter though its Weight may exceed that of the First; but is slow and lazy in its Action by reason of the Shortness of its Handle." These Arguments are fine and plausible: But for my part I cannot help thinking, that this may with much more reason be attributed to the *Construction* of the *acting Body* or *Mallet*, than to any other Accident; and I cannot persuade myself that the Density of the Air can any way contribute towards the Celerity of the *Mallet*, or make it fall the heavier upon the *Driver*; and my Reason is, because there can be but little Air in the Space taken up by the *Mallet* in its circular Motion: Add to which, that by a frequent Repetition of that Motion the Air interposed between the Active and Passive Body would

would be rarified and dispersed, instead of being condensed, and communicating an Increase to the Intensity of the Power of the Acting Body. But we shall in another place have occasion to trace out more particularly the Causes of the Rarification and Condensation of Air, where we shall examine in what degree the Air interposed between two Bodies (namely, between one fixed, and another moving naturally, or by any Force impressed) can either assist or destroy the Motion. I shall here remind you of what I said above (*viz.*) that the Force of an Arm that acts with Violence, greatly increases the Velocity of the *Mallet*, and consequently makes it fall the heavier upon any Object.

As to great *Rockets* you may conveniently drive them, if instead of a *Mallet*, you use a kind of *Beetle*, not much unlike what *Architects* and *Workmen* commonly drive down *Piles*, *Palisades* and *Stakes* with, provided you take care to have it of a moderate Weight. This *Engine* is composed of 3 *Spars* or *Poles* well fastened together at Top with a *Rope*, and spreads out in 3 *Legs* at the Bottom; and has two perpendicular *Timbers*, between which the *Ram* (as some call it) with its Iron Rings, and Head armed with the same Metal, is hoisted up by means of a *Rope* reaved through a *Pully* at Top, and being up, it falls down again by its own Weight upon the *Driver*; which by this Blow violently compresses, and consolidates the Composition in the *Rocket-Case*. If this *Beetle* does not exceed 100 lb, it may be easily kept going by two Men, and the longer the *Spars* are the higher will it be raised; and consequently falling through a greater Space in its Descent, the more will its Power be increased, according to that common Saying, *Gravis Casus ab alto*. *Mar. Merfennus* in his *Hydraulics*, *Balistics* and *Mechanics*, treats largely of this, to whom I refer such as are desirous of being particularly instructed in it. Let us now return to the rest of our *Instruments*.

Fig. 41. In Fig. 41 you have an Iron Cylinder terminating in a Point (or rather † *Punch*) towards the plane Superficies at Bottom, with which we pierce certain round Pieces of Pasteboard or strong Paper which are put

Fig. 42. upon the Composition after the *Rocket* is driven. Fig. 42 represents an Iron Cone that goes tapering to a very sharp Point, which may serve for the same Use as the former *Instrument*: In A you have a circular piece of Iron or Wood perforated in the Middle, which may be stopped with a small Nail or little Iron Pin, running into those Holes which you see all down the Cone with design to prevent the aforesaid Piece of perforated Wood or *Ring* from slipping. The Diameter of this *Ring* shall be such as may exactly fit the Orifice of a *Rocket* whilst the Point perforates C. This may serve for several *Rockets*, provided it be long enough, and that you have Iron *Rings* of several Sizes, adapted to the

Fig. 43. Orifices of them. Fig. 43 shews you the Form of a piece of Wood or

† He must here certainly mean a *Punch*; for it is certain that a *Punch* is fitter for the Work he mentions than a *Point*.

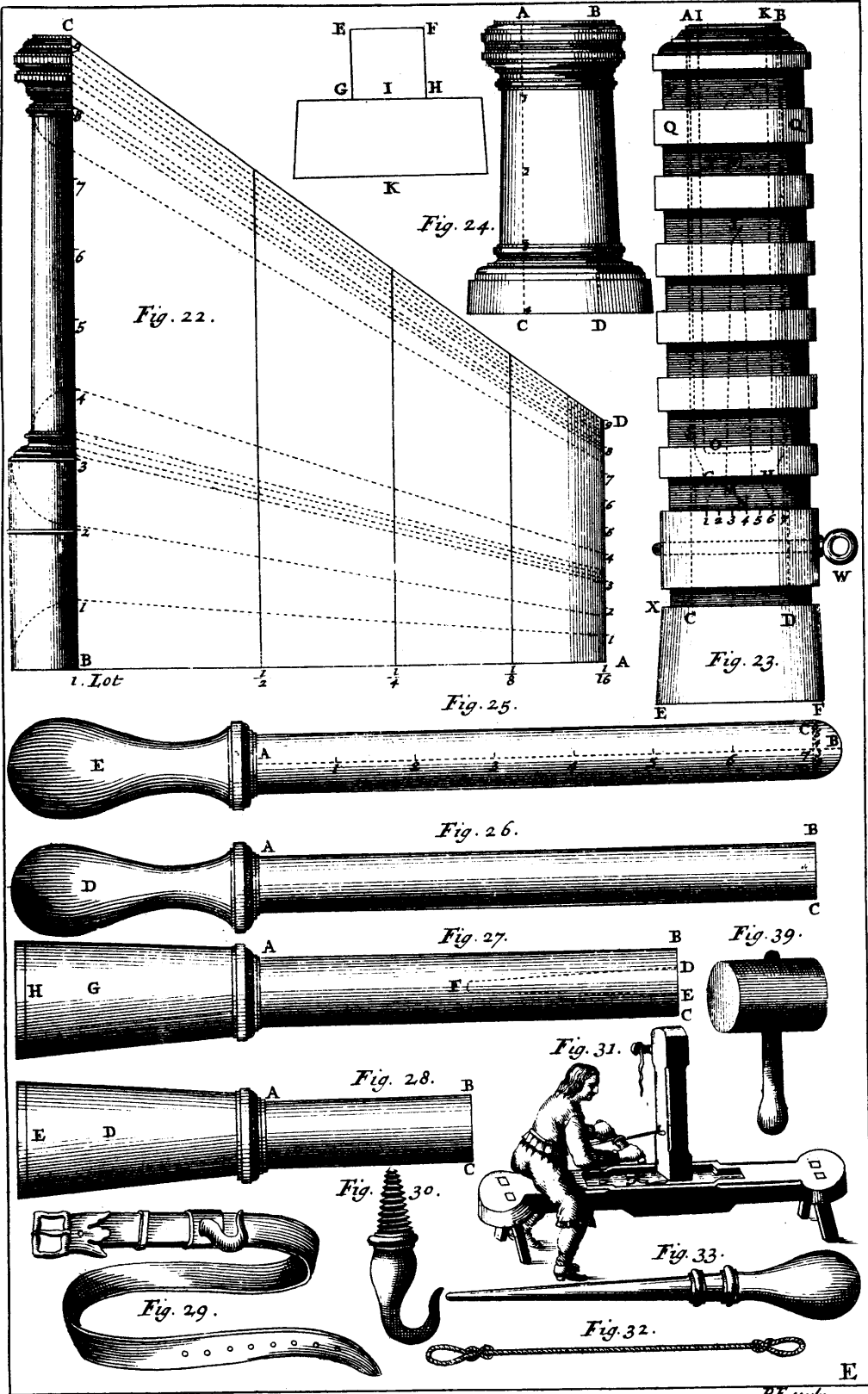

Cap, to cover the solid *Head* of the Composition in great *Rockets*, which is perforated in several Places, and has its Curve Surface hollowed in a Groove like the Sheave or Shiver of a Block or Pully, the use of which you shall know hereafter. *Fig. 44* represents the *Pyro-technic Knife*. In short, in *Fig. 45* you see several Tools distinguished by A B and C, for cutting, hollowing, and engraving all the Wood-work used in the Construction of *Pyrobolical Machines*, a great Number of which I shall give you in the following *Books*.

C H A P. IV.

How to mix the Ingredients, and prepare Compositions for all Sorts of Rockets.

OUR *Pyrobolists* may be very justly compared with the canting *Alchymists* of the Times past, (or the Present, if any are yet remaining) who, tho' they dealt in nothing but Smoke, yet arrogantly took upon them to be *Professors* of so noble and excellent an Art as *Chymistry*; and sweating Night and Day in search of the *Philosopher's Stone*, and other such Whims as subsisted no where but in their crazy *Imaginations*, to the fruitless Expence of their own Wealth or that of others; imposed their Fallacies on the *Weak* and *Unthinking* for Truths and Things of real Existence; like those *fugglers* who throw Dust into our Eyes, to hinder us from seeing through their *Tricks*; and who like them are, at the End of the Chapter, obliged to feed on *Coal*, *Asbes*, and the *Dregs* of their *Alembics*, and to drink the *Tears* forced from their Eyes by a perpetual *Smoke* as an agreeable *Ambrosia*. For even as those sooty *Adepts* carefully wrapped up the *Arcana* of their *Art*, or rather of their deceitful *Artifices*, which they upon occasion knew how to divulge with such specious Appearances of *Truth*, and of which if by chance they left any Account in writing, they neither expressed it in *Arabick*, *Chaldean* or *Syrian* Characters, but as a Science of *Diabolical* Extraction, and (if I may so express myself) immediately derived from *Hell* itself; and all with a Design to give their Profession the greater Weight with the *Vulgar*; knowing well that such *Things* as appear the most mysterious to them, and fall the least under their Apprehension, excite their *Admiration* the most, and immediately beget in them a longing *Desire* to be let into the *Secret*: Just so is it with our *Pyrobolists*, or at least with the greatest part of them, who seem to have contracted this evil Custom, and to have borrowed the *Alchymist's* ridiculous Politics: And accordingly they would have us believe, that they obtained the Secrets of their *Art*, with much difficulty from their Masters, or other Persons deeply versed in it: That these *rare Things* were communi-

cated to them in Pledge of perfect Friendship, or in Recompence for great Services done, or in return for secret Bribes of Money. But mark here their great Difingenuity, and Malice of Heart! for lest any one should easily come at a Knowledge of those *Secrets* which they so carefully conceal, or gather any thing from their confused *Memorandums*, they commonly express every thing used in *Pyroboly*, together with the *Weights and Measures*, by such uncouth Characters as are not to be understood by any but themselves. There are those, who have made certain explanatory Notes in unknown Characters to such Books as they had before printed, which if they should happen to be lost, *Farewel Science!* we have nothing more to do than to shut up our Books and our Shops too, and believe that we have lost the *Means* of enriching the *Pyrotechnic* Treasures, which had been locked up in those inestimable Cabinets. In truth, I should not disapprove of their Design, but should commend their extreme Diligence even in this Case, if they would pursue the Methods marked out by others, in their Endeavours to exalt their *Art* to the highest degree of Perfection: But it is a very great Weakness and Folly in a necessitous Man to be ashamed of borrowing from a Friend, what he hopes to repay very soon with Interest. It is a Task too tedious, and unequal to our Strength, to acquire an *universal Knowledge* by our own Industry, without the Assistance of others. But they are so far from being communicative that they do their utmost to hide what they have learned as holy and secret *Mysteries*; fondly thinking, that if they were to be divulged the Veneration they are had in would be diminished by the half, and that consequently the Professors of the *Art* themselves would lose a great share of the good Opinion the World had conceived of their Abilities. Indeed, I for my part have often seen great and mighty Collections of *Secrets, Remarks and Annotations*, (great and voluminous as to Paper, but small and thin with regard to Science) and upon Tryal have found that all those *rare Things*, which appeared so extraordinary to the Reader, were nothing but mere Smoke, the *Effluvia* of distemper'd Brains, or like Bladders swelled out with Wind, which can preserve their Bulk no longer than they remain unhandled and closed up. Since their Humour is of this odd Turn, I should think they would act more prudently, if they would try those Things they receive from others as valuable, and endeavour with all their Art to put them in Practice, before they insert them in their public Works, by doing which they would no longer deceive others, nor be deceived themselves. But the great Misfortune of these Men is their having a Notion, that all solid Learning consists in a vast Heap and Multiplicity of Articles and Inventions, which they collect together where-ever they find them, without knowing whether they be *Good or Bad, Valuable or not*; but every thing shares in their Esteem that does but contribute to swell up their Works. But to have done with this Topic; I think those take the most prudent and commendable Method in their *Pyroboly*, who
make

make use of but one or two *Compositions* only which they know to be good, whether they be of their own Invention, or whether they be received from any other, whose Purse is better able to go through those expensive Experiments, provided always, that they are founded upon Reason, and Geometrical Demonstration. Now it being my Design to treat of the necessary *Compositions* for all sorts of *Rockets* in this Chapter; I shall endeavour to shew (being certain that no one ever attempted it before) by what means, and in what Proportion the *Ingredients* ought to be mixed for the *Compositions* of all *Rockets*; to the end that from the fine Harmony of their Assemblage, and what else you will find in the Sequel of this Work, you may reap the Fruit and Benefit of our great Labour.

We find so vast a Number of *Compositions* amongst the Professors of this *Art*, that it is as much as we can do, to guess which are the best of them; for if we were to try them all, it would take up a great deal of Time and Money. Upon this Account it is that I have given myself the trouble for many Years past of seeking after a Method, by which I might readily come at a Knowledge of the Goodness of any *Composition*; and have been so nice in my Research, as to put none in Practice till I had examined them by an exact Arithmetical Calculation, Geometrical Demonstration, and by solid Arguments drawn from *Natural Philosophy*. It is here then (*Candid Reader*) that I not only give you leave; but if you are a good *Pyroballist*, or if you have never so little a smattering of the Mathematical *Elements* joined to a little Knowledge in *Physics*; I do even entreat you to examine all the *Compositions* which I am here going to offer you, thoroughly and to the bottom: For I am pretty well assured that you will find nothing to disapprove of in either my *Theory* or *Practice*. But *First* you ought to know the following general Rules, which will serve as a Touchstone to try the Value of all *Compositions*, whether they be of your own Invention, or communicated by others; and by means of which also you may contrive new ones at pleasure.

The first Rule is: *Rocketæ quo majores fuerint, lentiori onerentur materia: quo autem minores fortiori.* That is; the larger *Rockets* are, the weaker and slower shall their *Composition* be; and on the contrary, the lesser they are their *Composition* must be the stronger and quicker. This must be carefully observed: And the reason is; because when the Fire seizes upon a strong *Composition* in a great *Rocket*, it will devour more of it in a Moment, than it could in a small *Rocket* in one, two or several Minutes; for as there is a greater Cavity in large *Rockets*, the Fire has an Opportunity of preying upon a great deal of Matter at once, and accordingly consumes a considerable Quantity of it in an Instant. It is a very difficult thing to prescribe Laws to Fire, which is the most active and voracious of all the Elements, and much more to set determinate Bounds to its Action whilst there remains any combustible Matter
for

for it to destroy. From hence it will necessarily follow, that a strong *Composition* producing a sudden and instantaneous Combustion, it must, when in great *Rockets*, burst them somewhere or other. Now this happens from the too great Concourse and Density, or to express myself clearer, from the extreme Confluence and close Union of the Rays of Fire issuing from the Sides of the hollow Cone, which together with the great quantity of † *windy Exhalation* (generated by the Accension of the *Salt-peter*;) being too much straitned, and requiring more room, they by their Impatience of Confinement forcibly break through the Pasteboard or Wooden Walls of their Prison. But the Case is quite different in small *Rockets*; for the Fire consuming the strong *Composition* in them by slow Degrees only, the Rays of *Fire* issuing from the Sides of their hollow Cones are fewer in Number, and in so narrow a place they have not so much *Wind* or *Exhalation* to rarifie at a Time, and therefore are in no danger of bursting.

The Second is: *Ad majores Rocketas quæ unam libram, vel duas ad summum superant; non alligetur aliis materiis pulvis Pyrius.* For great *Rockets* that exceed 1 or 2 lb at most, you shall mix no *Gun-powder* with the other Ingredients. I have no other Reason to give for this, than what I just now mentioned; for when *Gun-powder* is mealed, it must be beaten and pounded very much, by which means it is endowed with an extraordinary Force; for the repeated Strokes add a great deal of Heat to it, and even Fire itself; in short, the Pounding unites the *Salt-peter* with the *Coal* and *Sulphur*, and converts them into a Substance that is perfectly Igneous, after having purged them of all hurtful Moisture. Upon this Account it is, that a little *Gun-powder* has more Virtue and powerful Effect, than any quantity of *Salt-peter* that might be used in *Compositions* in different Proportions.

In short, the Third is: *For great Rockets from 100 lb down to 10 lb, you must first take such a quantity of clarified or purified Salt-peter as shall be equal to the Coal and Sulphur; and then afterwards let it be in a simple unequal Geometrical Proportion of Superparticular or Superpartient: but from 10 lb down to 1 lb or ½ lb, let it be first in a Double Proportion, then Triple, and then Quadruple, and so on, of the Aliquot Parts of an Integer. In short, from one lb to the very least Rocket, let the Salt-peter be taken together with the Gun-powder in several Degrees of Superparticular and Superpartient, as Sextuple, Septuple, Octuple, Noncuple and Decuple; or Sixfold, Sevenfold, Eightfold, Ninefold and Tensfold. The Proportion of Coal to Sulphur, shall be either Sesquialteral, or Double, or Triple, and sometimes Equal.*

† This is what we mean in the second Book by *Flatulent Expansion* — both these Expressions bear one and the same Signification; but this is most intelligible here, and *Flatulent Expansion* is more proper in the other Place.

Observe here however, that you must increase and diminish the Quantity of *Saltpeter* with regard to the two other Ingredients, as the *Coal* is to the *Sulphur*, and reciprocally as the *Sulphur* is to the *Coal*, so must they both be to the *Saltpeter*; as if (for Example) you begin by great *Rockets*, you augment the Quantity of *Saltpeter* by degrees, and diminish the two other Ingredients in such Proportion as not to deviate from this *Arithmetical* Progreffion. Whenever you contrive new *Compositions*, I advise you to try them before you make them public, and put them in Practice privately, that you may avoid Mistakes, and correct such Errors as you might have fallen into.

As for *Compositions* that you receive from others, you may examine them, if you understand never so little of *Geometrical* Proportions, and the Use of them; or if you will make the Experiments according to the Rules here laid down.

Accept then favorably of these following *Compositions*, which I give you for your Amusement at your leisure Hours. I here deliver them to you with all the Fidelity I am capable of, from those of 100 lb down to the least *Rocket* that can be made. But by the way, I have not confined myself to any particular *Arithmetical* Progreffion with regard to the Proportion of *Coal* to *Sulphur*, as I proposed above; and indeed it is not absolutely necessary: But I only give you the *Compositions* in the Proportion and Order, I found them in my several Experiments of this kind. However, if you take upon you the trouble of proving and reducing them to an *Arithmetical* Calculation, you will find that I have strictly observed our First general Rule in all my *Compositions*.

Compositions for all Sorts of Rockets.

From 100 to 80 and 60 lb.

Of *Saltpeter* 30 lb, of *Coal* 20, and of *Sulphur* 10 lb.

In this *Composition* you have the *Saltpeter* equal to the two other *Ingredients*, but the *Coal* is double of the *Sulphur*. You may freely use this *Composition* for all *Rockets* that can be made from 100 to 60 lb; for it is best to let their *Composition* be weaker than what they perhaps can bear; It being by much the safest with regard to *Powder* to err on the weak side, that is, by allowing rather too little than too much Strength; for the Weakness of a *Composition*, or of *Powder* either, may be easily remedied by adding a Portion of violent Matter: But in order to be assured how your *Composition* will prove, you may make Tryal of one *Rocket* before you drive any of the rest; from whence you may conclude concerning what you may expect from the others.

From 50 to 40 and 30 lb.

Of *Saltpeter* 30 lb, of *Coal* 18 lb, and of *Sulphur* 7 lb.

Q 9

From

From 20 to 18 lb.

Of *Saltpeter* 42 lb, of *Coal* 26 lb, and of *Sulphur* 12 lb.

From 15 lb to 12 lb.

Of *Saltpeter* 32 lb, of *Coal* 16 lb, and of *Sulphur* 8 lb.

From 10 lb to 9 lb.

Of *Saltpeter* 62 lb, of *Coal* 20 lb, and of *Sulphur* 9 lb.

From 9 lb to 8 lb and 6 lb.

Of *Saltpeter* 35 lb, of *Coal* 10 lb, and of *Sulphur* 5 lb.

From 5 lb to 4 lb.

Of *Saltpeter* 64 lb, of *Coal* 16 lb, and of *Sulphur* 8 lb.

From 3 lb to 2 lb.

Of *Saltpeter* 60 lb, of *Coal* 15 lb, and of *Sulphur* 2 lb.

Of one lb.

Of *Gun-powder* 18 lb, of *Saltpeter* 8 lb, of *Coal* 4 lb, and of
Sulphur 2 lb.

From 18 *Loths*, or 9 *Ounces*, to $\frac{1}{2}$ lb,

Of *Powder* 18 lb, of *Saltpeter* 8 lb, of *Coal* 4 lb, of *Sulphur* 2 lb.

From 12 *Loths* to 10 *Loths*.

Of *Powder* 30 *Loths*, of *Saltpeter* 24 *Loths*, of *Coal* 8 *Loths*, and
of *Sulphur* 3 *Loths*.

From 6 *Loths* to 4 *Loths*.

Of *Powder* 24 *Loths*, of *Saltpeter* 4 *Loths*, of *Coal* 3 *Loths*, and
of *Sulphur* 1 *Loth*.

From 2 *Loths* to one *Loth*.

Of *Powder* 30 *Loths*, of *Coal* 4 *Loths*.

From $\frac{1}{2}$, $\frac{1}{3}$, $\frac{1}{4}$ to, $\frac{1}{8}$ of a *Loth* or half *Ounce*.

Of *Powder* 9 or 10 *Loths*, and of *Coal* 1 or $1\frac{1}{2}$ *Loths*.

The smaller sort, called with us *Serpents* or *Squibs*, may be of *Meal-Powder* only, except the *Priming*, which ought to be of *Corn-Powder*.

C H A P.

C H A P. V.

Of the Boring of Rockets, and several Instruments proper for that Work.

AS for the *Boring of Rockets*, or the means of piercing their solid *Composition* in a certain determinate Proportion as to Breadth and Height; whether it be done at the same time that you drive them, or after they are driven; it is an Invention which I can give you no great Historical *Account* of, nor inform you whether it be New or Old. However, I cannot but think that the ancient *Pyrobalists* were well acquainted with an Article of such Importance in the Construction of *Rockets*; without which it would be impossible for them to fly upwards; for it is owing to this Contrivance, that the *Fire* is able to accend the *Composition* in such a manner as to have its Rays collected to a Center, and by their united Efforts, to force up the *Rocket* and all its Furniture as long as there is any Combustible Matter left. But I am inclined to think, that those good *Gentlemen* reserved it in Silence as a very great Secret of their *Art*: Or else we may believe, that they designedly skipped over this Article, contenting themselves with initiating us into several other Mysteries of this *Science* which they freely enough divulged. Now for my part, after having read over and over again all the Writings of the ancient *Pyrobalists*, I never met with one Syllable of Instruction relating to the Method of *boring Rockets*. In truth, I do not much wonder at this; because I know it is at this Day the Custom of *Fire-Workers* (and they religiously observe it) not to reveal any Secrets concerning *Fire-works* without much Importunity; and whenever they do communicate any of them, it is to such Persons only, who make this *Science* their particular Profession; or perhaps to such as promise them *great Things*: Or they may happen in their Drink to declare all they know, together with what they know nothing of; and so let these *Arcana* fall from them amongst the rest of their drunken Discourse; which in their sober Intervals would have been retained within their own Breasts. But be this as it will, certain it is, that the Professors of this *Art* force a solemn Oath from their Disciples, after they have gone through a proper Course, and that they are upon the point of dismissing them; in which Oath they swear never to reveal what has been communicated to them to any Person whatever, and oblige themselves not to make a public Profession of it, nor to teach it privately to others till after a Period of three Years. In this they imitate the *Cabalists*, who never initiate any into their Mysteries, but such as are filled with a Divine Spirit, and (as they

they say) such as were predestinated from their Mother's Womb to receive the Sacred Gift of *Prophecy*, or rather of *Pseudo-Prophecy*: Mysteries which they hold in the utmost Veneration, and perform with extraordinary Ceremonies, muttering I know not what between their Teeth, with express Prohibition (a Superstition punishable with Death) never to reveal them to any living Soul. But as for me, far from entertaining such narrow Sentiments, far from being actuated by such a Spirit, or expecting any Reward; I here give you *Gratis*, what I purchased at so dear a Rate: And breaking Silence to oblige my Friends, and serve the Public; despising all the Réproaches and *Anathemas*, which those *worthy Gentlemen* the *Pyrobolists* may thunder out against me; I here declare openly and plainly, *That Rockets ought to be bored to the Height of $\frac{2}{3}$ of the Composition or Matter wherewith they are filled, minus a Diameter of their hollow Cylinders.* The Breadth of the Orifice at the Choak shall be $\frac{2}{3}$ of the Diameter of the Mould, and go tapering up towards a Point like a Cone, in such manner that the Upper Breadth of it shall be $\frac{1}{3}$ of the Lower; for a Cavity of this Form will be the best adapted for receiving the *Fire* in such a manner as to oblige the *Rocket* to take its Flight. There are two Sorts of *Instruments* used for making these Cavities (namely) hollow *Borers*, and certain *Needles*

Fig. 46.

or *Piercers* of Iron or Copper, made in fashion of a Cone. In Fig. 46 you may see a Representation of these, distinguished by the Letters A B C D E. A, the first, is for *Rockets* of 2 lb: Its Height, B C, is $\frac{2}{3}$ of the Height of the *Rocket* minus a Diameter of its hollow Cylinder, beginning to measure it from that Point where the Composition begins (*viz.*) at the Neck or Choak, to that Point where the Matter in the *Rocket* terminates. For Example, in Fig. 48 the Height of the *Rocket* from P to I being divided into three equal Parts, two of them will reach to G, then from G, subducting N O a Diameter of the hollow Cylinder of the *Rocket*, and setting it off downwards towards F, you will have the proper Height of the Cavity P F or E F (*viz.*) $\frac{2}{3}$ of the Height of the *Rocket* minus a Diameter of its hollow Cylinder: And its Breadth E P will be $\frac{2}{3}$ of the Diameter M B. The Upper Breadth of the above-mentioned *Borer* in C is $\frac{1}{3}$ of the Lower Breadth D E. In Fig. B,

Fig. 48.

which is the Second, you have a *Piercer* for *Rockets* of 12 *Loths* or 6 *Ounces*. C is for those of 8 *Loths* or 4 *Ounces*. D for those of 6 *Loths* or 3 *Ounces*; and in short, E is for those of 2 *Loths* or 1 *Ounce*. Now the Proportions of these Last are the same with those of the First in Letter A. You have moreover in the first Fig. A, Divisions expressing the *Piercers* of small *Rockets* down to $\frac{1}{4}$ lb each distinguished by its proper Number. Know then, that I made these Divisions in a Cubical *Ratio*, by dividing the right Line B C (which is the Length for the *Borer* of a *Rocket* of 2 lb) into Parts Cubically proportionate to it; as into Subduple, which is one lb: Into Subquadruple, which is $\frac{1}{2}$ lb or 16 *Loths*, and so on of the rest that are between any two of them. And tho' we might

might in this manner have given the several smaller *Borers* deduced in proportion from one exceeding 2 lb, I avoided it because I would not have the Upper Breadths of small ones too much disproportioned to their Lower Breadths; or else we must be obliged to diminish the Upper Breadth of a great *Borer*, so as to serve for *Rockets* of 1 or 2 *Lotbs*, but they would in that Case be apt to be too narrow. Therefore you will do better to have your *Borers* for small *Rockets* separate from the greater sort; by doing of which you will have them all nearly in one and the same kind of Proportion. Your *Borers* should have a little sort of Handle, that you may the more conveniently guide them; a Representation of which you have in *Fig. F.* The Letter D in *Fig. 47* Fig. 47. shews you another Handle which turns the *Borer* like that of a *Wimble*. In short, all the Sizes of them may be easily fixed in a Turner's Leathe for boring of *Rockets* expeditiously and nicely. But if this Way does not please you, you may use the little *Machine* which you see in *Fig. 47.* which is very conveniently contrived for this Work: You must first then have a piece of Timber in Form of a Parallelopiped, sawed through the Middle of its Breadth; or else composed of two Semi-Parallelopipeds, each of which shall have one Side hollowed Lengthways, so as to fit and hold a *Rocket* between them, as appears in A and B. This Parallelopiped shall be shut up in the *Machine*, or (as we may call it in *English*) *Square Frame*, and pressed close together with four Wooden Screws, two on each Side, as F and E, to hold them fast, and prevent them from slipping: Then taking the *Borer* C in the Handle D, you shall set the Head or End of it to your Breast, and turning it round with your Hand, bore your *Rockets* at pleasure. There is another Way of doing this (namely) by driving your *Rockets* upon Iron or Copper *Piercers* with hollow *Drivers*: We have given these the very same Proportions as we have assigned to the *Borers*. This kind of *Piercer* ought to be fashioned as you see in *Fig. 23,* where M L is its Length, and Fig. 23. G H its Breadth. I must own, I have allotted another Proportion to *Piercers* both as to their Upper and Lower Breadths in *Fig. 20,* where the Breadth O P is $\frac{1}{2}$ of the Diameter C D, and the Upper Breadth at Q $\frac{1}{3}$ of the Lower Breadth O P. This I did, because I have observed that several *Pyrobolists* use this Proportion; which I can in no wise disapprove of, having never seen the Effects of *Rockets* driven upon such sort of *Piercers*. To this I shall add, that *Borings* are not always made of the same Bigness, whether as to Breadth or Height, and I will not affirm, that my Observations will hold good in all Cases, particularly with regard to those, who make it a Practice to drive one Size of *Rockets* with several sorts of Compositions; for you must consider that the stronger a Composition is, the straiter and shallower ought the *Boring* to be, and on the contrary, that the weaker and slower it is, the wider and deeper must it be *pierced*. The Reason of this may be easily gathered from what we said in the foregoing Chapter; for as a strong Composition in-

flames sooner than a weak one, the *Rocket* which is filled with too violent a *Mixture*, and has its Orifice too wide, would let in the *Fire* too abundantly, and instead of departing, would be consumed in an instant; inasmuch as the *Fire* having too much room in so capacious a Cavity to act in, would in a Moment possess itself of all the *Matter*, reduce it universally to a Flame, and would most commonly burst the *Case*, or else after having mounted to a considerable Height, it would at once disperse and appear like a Flash of Lightning. Small *Rockets* are in no danger of this, because of the little quantity of Composition they contain; but for Great ones, be particularly cautious to fill them with a Composition proportioned to their Size, and to bore them in proportion to the Composition they are filled with; or else be assured that your Labour and Expense will vanish in Smoke. Here then (*Friendly Reader*) is what former *Pyrobalists* have so industriously and so long hid from us; which ungrateful and envious Contagion of *Secrecy*, has spread down to the Professors of this *Art* in our Days, who are so far tainted by it, as to imagine, they should greatly prejudice their Reputations and private Interests, if they communicated any thing they make a *Secret* of, to such deserving and curious Persons as might have a Genius for this Science. They either do not consider, or do not know what daily Experience teaches us; (namely) that a Thousand extinguished Lamps may be lighted at one, which will communicate a Flame to them all, without being any way impaired itself either by a Diminution of its Oil, or the Loss of one single Atom of its Fire. As for me, I make no scruple of publishing an ingenuous Declaration of what ought not to be concealed. I indeed foresee, that those *Triflers* (they deserve this Appellation both on the score of their Ignorance and Mean-spiritedness) those ungenerous Souls will hate me with more than a † *Vatinian* Hatred. But that gives me no manner of Disturbance; for I know that People of any share of good Sense will laugh at their Snarls, or take no Notice of them, particularly if they recollect that common and true Saying, *Principibus placuisse viris vel maxime sat est*. Those vulgar Wretches are but little Dogs, that bark at us, without being able to bite; and if our Labours prove acceptable to our Princes, no matter for any thing else.

But let us have done with this Topic, and proceed farther on in the Construction of *Rockets*, and set our Hands in good earnest to the Work.

† This Saying is derived from *Vatinus*, the Name of a Person who bore a remarkable Hatred to the famous Orator *Cicero*.

C H A P. VI.

Of Sky-Rockets that mount up with their Sticks.

S O R T I.

THE *Rocket* represented in *Fig. 48*, which we have already sup-*Fig. 48.* posed to be of 1 lb, has its Height A B 7 Diameters, in like manner as is its *Mould*: But from this Height we must first retrench $\frac{1}{2}$ a Diameter for the Neck L M, as the Line B D shews upon A B. Moreover for the Binding and the Folds of the Choak to E $\frac{1}{2}$ Diameter must be cut off or allowed; and in short, for the Binding of the Head, you again take from this Height $\frac{1}{2}$ a Diameter, as may be seen in K I and A C; therefore the Height of the Composition and *Report* will be $5\frac{1}{2}$ Diameters, as you see in E I or C R. Now divide this Height into three equal Parts in the Points S and G and fill it, with a Composition futable to its Size (as we have already cautioned you) from E to G, that is, to $\frac{2}{3}$ of the Height E I. This done, cover it with a little Cap of Paper or Pafteboard G; or what will be much better for great *Rockets*, a round hollowed Wooden Cap, such as you see represented in *Fig. 43*, which shall be firmly glued to the Sides of the *Rocket*. If your *Cafe* be made of Paper or Pafteboard, you shall with a strong Cord choak or force it into the Hollow in the Curve Surface of this Wooden Cap, which Cord may remain to confine it in, as you see in Q. But if the *Rocket-Cafe* be made of Wood, this Cap need not have its Convex Surface hollowed, but let it be uniform and plane; allowing its Thickness to be $\frac{1}{3}$ of the Diameter of the *Rocket*. You shall fasten it to the Inside of the *Cafe* with little Nails or Wooden Pegs, which shall be driven into it from the Outside, and then well secured with Glue. You must be particularly careful in doing this; for I have often seen the *Cases* of great *Rockets* remain empty upon the Nails without rising at all, and the Composition for want of being powerfully confined at Top, slip up through the *Cafe*, and consume in the Air without performing the Effect expected. However, small *Rockets* which are choaked at Top are not liable to this Accident. There must be an Hole made through this Cap of $\frac{1}{4}$ of the Diameter of the *Rocket*, several of which may be made, if upon this Cap you would put Running *Rockets*, or (as they are usually called in *English*) *Squibs*, and other little Decorations, which are used in artificial *Fireworks*, which we shall speak of hereafter. Over this Cap you shall fill the Remainder of the *Cafe* with good Corn Powder, which shall be pressed down so gently, as no way to have its Corns defaced or broken, that they may be able to retain their Vigour. In short,

short, it shall be bound up close at Top, and then bored from E to F, to the Height of $\frac{3}{4}$ of the Length of the *Rocket*, minus a Diameter of its hollow Cylinder (*viz.*) N O; which being set off downwards from G towards E, gives E F, which is the Height it ought to be bored.

S O R T II.

Take a *Rocket-Cafe* whose hollow Cylinder is equal in Diameter to a Leaden Bullet of 10 *Lotbs* or 5 *Ounces*; let its Height be 4 and $\frac{1}{2}$ Diameter, and filled with a futable Composition to 3 Diameters, and then bored to the Depth of two of the same: Cover the Composition with a Wooden or Pasteboard Cap, having an Hole through it of $\frac{1}{4}$ of the abovementioned Diameter, then let the Top be closed up firmly with a strong Packthread. The Fashion of this *Rocket* may be seen in Fig. 49, where it is distinguished by the Letter A. This done, take another *Cafe*, the Diameter of whose Orifice is equal to that of a Leaden Bullet of 24 *Lotbs* or 12 *Ounces*, and let it be 5 Diameters of its *Mould*; this shall be filled with a proper Composition, to the Height of $1\frac{1}{2}$ Diameter of its Orifice, and artfully bored to $1\frac{1}{2}$ of the same Diameter, so that there may remain $\frac{1}{2}$ of a Diameter of solid Head. Cover this with a Cap as before, and upon that, Corn Powder to the Height of $\frac{1}{4}$ of a Diameter. In short, over all this you shall put the *Rocket* you had before prepared, which shall be firmly pasted to the Inside of this. You will see the Construction of this last *Rocket* with the first in it in the same *Figure*, distinguished by the Letter B. To conclude; take the *Cafe* of a Third *Rocket* of 2 lb, whose Height shall be to its Diameter as we prescribed in the Second Chapter of this Book, and fill it with a futable Composition to the Height of $2\frac{1}{4}$ Diameters; you shall cover this with a Wooden Cap, whose Thickness and the Diameter of the Hole through the Middle of it shall be $\frac{1}{2}$ of the Diameter of the *Mould*; and over that, a *Report* of Corn Powder to the Height of one Diameter of the *Rocket*. This done, take the *Rocket* B, with the first *Rocket* A in it, and putting it into the Hollow of this Third, glue or paste them nearly together, and cover them all three with the Conic Head F, made either of Wood or Paper. You have the whole Order of this *Rocket* in the same *Figure*, distinguished by the Letter E.

Observe here First, that the Necks of the two first *Rockets* do not exceed $\frac{1}{2}$ Diameter. Secondly; that you may take three Larger or three Smaller *Rockets*, and dispose of them after this manner. But you must take care, that your two Lesser ones be shortened in such a manner, that the Third may not lose any of its Height; and in like manner on the contrary, that they be not so high as never so little to exceed the Third that contains them; and let them be always so proportioned, that the First exactly fills up the Second, and the Second with the First in it exactly fills up the Third. If it happens that the Necks of your

Rockets

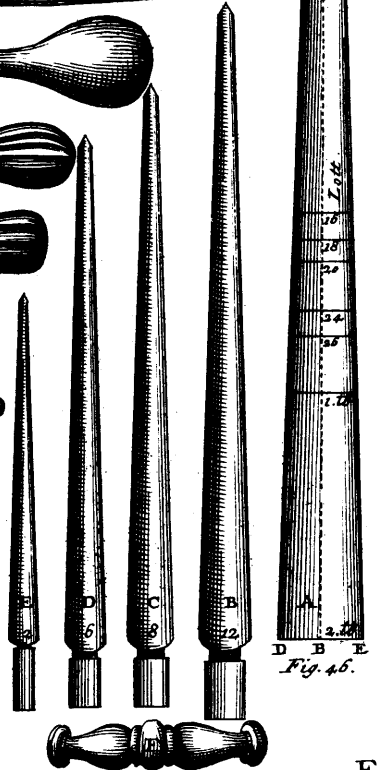
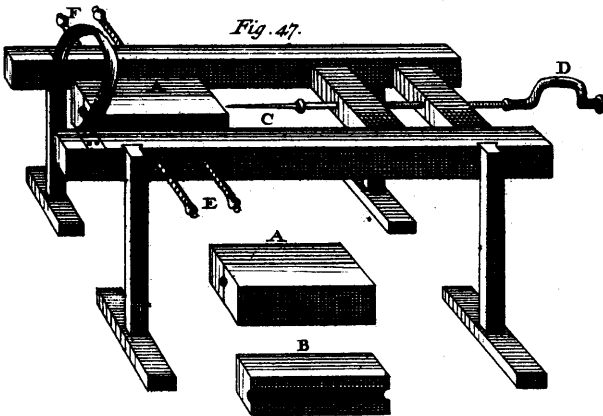
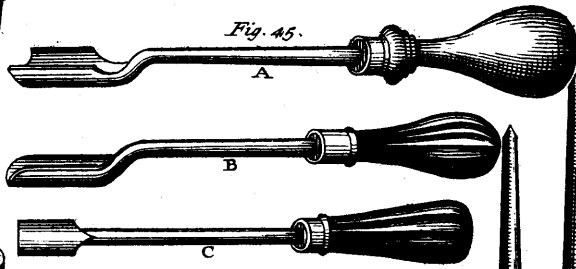
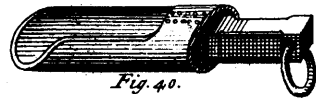
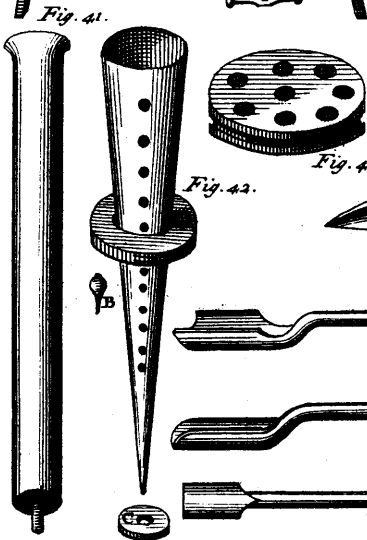
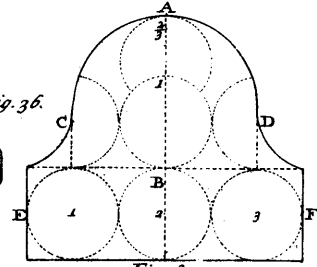
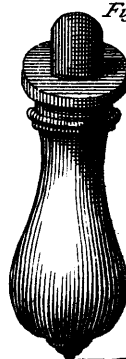
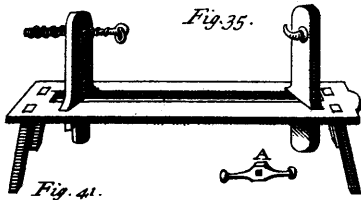
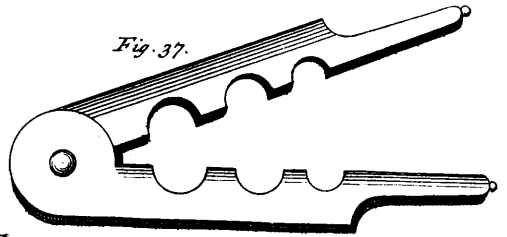
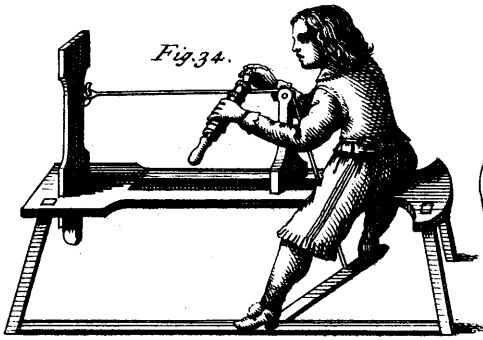

Rockets do not nicely observe the Proportion I have laid down, it will be no great matter, provided that their Diameters are as they ought to be: And in this Case, the Third *Rocket* must be driven with a slower Composition than its Size requires. Thus the two First will by the Third be carried up into the Air, where they perform their Parts; flying from one side to the other in Oblique Directions; for they cannot ascend perpendicularly, for want of Sticks or a Counterpoise; but we shall touch upon that at the End of this Chapter.

S O R T III

Take a great *Rocket* (*viz.*) of 2, 6, 8, or if you will of 10 or 20 lb; and fill it with a Composition futable to its Size, and bore it as usual; according to the Method directed in the first Sort of *Rockets*; and after having covered it with a Cap, with several Holes pierced through it as you may see in A, you shall salt it over with *Meal Powder*, mixed with an equal Portion of that in *Corns*. Then fill up the remaining Cavity of the *Rocket* with small Running *Rockets*, or (as we call them in *Englisch*) *Squibs*, and leave a Space in the Middle of them, for a Wooden Case or Tube, which you see represented in *Figure 54*, and *Fig. 54.* which you shall prepare after the following manner. Take a hollowed Cylinder or Tube of Wood, equal in Height to the Space left of the *Rocket*; or it may be continued up to the inner *Vertex* of the Cone that crowns your *Rocket*. Let the Thickness of the Wood a b, be $\frac{1}{2}$ of the Diameter a c; and let the Bottom f g be $\frac{2}{3}$ of the same Diameter, to which may be fastened a Leaden Bullet by way of Counterpoise. This Tube or Case shall be filled thus: First, pour in *Corn Powder* to the Height of $\frac{1}{2}$ a Diameter, and upon that a *Light Ball*, the Construction of which I shall teach you in the Third Chapter of the next Book; over this Ball put *slow Composition*; upon this, *Corn Powder* again in the same Proportion as before, and upon that another *Light Ball*; then *slow Composition*; and in this Order you must proceed till your Case or Tube is filled up. We shall treat of *slow Compositions* hereafter; and in our Book of the several *Pyrotechnical Machines*, we will enlarge upon what relates to this same *Case*. The whole being disposed after this manner, and the Tube filled as we have directed, well reinforced with good Iron Wire, or strong glued Packthread, for fear the *Powder* should split it, it shall be fixed in the Middle of the *Squibs* with its Mouth downwards upon the *Meal* and *Corn Powder* abovementioned. The whole being thus compleated, shall be closed at Top with a Wooden or Paper Head, according as the *Rocket-Case* is made of either the one or the other of them. You have a full and particular Representation of this in *Fig. 50.*

Fig. 50.

S O R T IV.

This kind of *Sky-Rocket* differs but little from the foregoing, except that instead of small *Rockets* or *Squibs* in the empty Space above the Composition, you put either Sparks or Stars (which we shall teach you to make in the Third Chapter of the following Book) interspersed with *Meal* and *Corn Powder*: As for any thing else relating to it, you are to proceed in the same manner we did with the First. See the Representation of this in *Fig. 51*.

Fig. 51. tation of this in *Fig. 51*.

S O R T V.

You shall take a *Rocket* of any Size you will, and fill it with a proper Composition to $2 \frac{1}{2}$ Diameters of its Orifice or hollow Cylinder; and cover it with a Wooden Cap, whose Thickness is $\frac{1}{2}$ of the same Diameter; and over that, *Corn Powder* to the Height of $\frac{1}{2}$ of a Diameter; and upon that, Composition to $\frac{1}{2}$ of a Diameter: This must be covered with a Cap, and that again, with *Corn Powder* as before; and upon that, Composition as before, and so on till the *Rocket* is quite filled. This done, it shall be tied close and firm at Top, and bored to the Depth of

Fig. 52. $2 \frac{1}{2}$ Diameters. *Fig. 52* shews you the whole Order of this.

S O R T VI.

You shall first take a *Rocket*, and fill it according to the common Rule and Order, and bore it as we did the *Rocket* of the First Sort. This done, prepare certain Boxes or Cafes of dry light Wood, the same as you see represented in *Fig. B*, under *Fig. 53*, or else firm Paper Cafes like those of *Rockets*, choaked close at Bottom. Then with hot Glue stick as many as you please of them, to the exterior Surface of the *Rocket* as you see in C, minding to place them in a Spiral Direction, and tie them fast with good Packthread as you see in the Letter D. Into each of these Boxes put a *Running Rocket*, filled with *Meal Powder*, and opened at the Choak, through which and the Boxes, the Fire may be conveyed from the great *Rocket*. The great *Rocket* might serve for a *Petard* or *Cracker* filled with *Corn Powder*, but instead of that, you may use Iron *Crackers*, whose upper Part shall be filled with fine *Powder*, and the lower Part with *Rocket* Composition. The Letter A shews you one of the abovementioned Boxes, with the *Running Rocket* in it, to render the thing more easy to your Apprehension.

Fig. 53.

S O R T VII.

Fill a *Rocket* with a reasonable Composition, to the Height of 2 Diameters of its Orifice; and bore the said Composition to the Depth of one Diameter, and to the Breadth of $\frac{1}{2}$ Diameter. Cover this Boring with a piece of Paper only, to prevent its being filled up whilst you drive the rest of the *Rocket*; this Order you are to observe till your *Rocket* is quite filled; (namely) by always putting in 2 Diameters of Composition and boring one. See *Fig. 55.*

Fig. 55.

S O R T VIII.

You must here observe the several Circumstances relating to the First, Fourth, and Sixth Sorts, as well in filling this *Rocket*, as in boring it. Suppose then, that you have a *Rocket* prepared as it ought to be: You shall stick round the Outside of it, as many Paper *Crackers* as you shall think fit, (such as you see distinguished by A) and at such Distances as you shall think most proper. Then prime both them and the *Rocket* with *Meal Powder.* *Fig. 56* plainly illustrates this.

Fig. 56.

S O R T IX.

This Ninth Sort of *Rocket* shall be prepared after the following Order: You shall first fill the *Rocket* with a suitable Composition to the Height of 2 $\frac{1}{2}$ Diameters; which shall be covered with a Wooden Cap, having an Hole through the Middle of it: And over the Cap you shall put a Layer of *Corn Powder* to the Height of $\frac{1}{3}$ of the Diameter of its Orifice; upon which shall be a Layer of *Composition* to the Height of $\frac{1}{3}$ of the same Diameter. Then taking a strong Cord, choak the *Rocket* close above the *Composition*, leaving only a small Hole of Communication in the Middle of it. This done, you shall put in *Composition* afresh to the Height of $\frac{1}{3}$, and upon the said *Composition* *Corn Powder* to the Height of $\frac{1}{3}$. In short, upon this *Powder* you shall put *Composition* to the same Height as before, and choak it again a second time. In this Order you shall proceed till the *Rocket* is filled up. This will appear obvious to you in *Fig. 57.*

Fig. 57.

S O R T X.

This *Rocket* has nothing particular in it, to make it very different from the rest; for, first, it is filled and bored after the same manner with those of the First, Fourth, and Sixth Sorts. There is only an Addition to it of a *Report*, and upon that, a longish hollow piece of Wood in a Spherical Form, fill'd with an Aquatic Composition, (by
Aquatic

Aquatic, I mean such Compositions as are contrived to burn upon or in the Water, which I shall give you in the following Book) or any other strong Mixture. You must fire this *Rocket* at the Head before you fire it at the Orifice of the Choak, because the upper Composition has no Communication with the lower Part of the *Rocket*. Being then moved off, and having taken its Flight into the Air, you will see two Sorts of *Fire* (namely) that of the *Rocket* darting its Rays downwards, and the other issuing from the Head, and spreading abroad in the Air like a

Fig. 58. great Fire Rain. This is clearly explained to you in *Fig. 58*.

S O R T XI.

Take 7 small *Rockets* of 2, 3, 4, or more *Ounces*, filled with a common Composition; and bored as usual: Bind them up together in a round tight Bundle, and wrap them about with strong Paper or Pafte-board, and head them with a large Cone of the same, as you see in A. You must not forget to stick them (I am just going to instruct you in the Rules relating to *that*) in such a manner, that the upper End of the *Stick* may come under the great Paper Case that encompasses the

Fig. 59. *Rockets*. *Fig. 59* will fully instruct you as to this.

Observe here that the several Sorts of *Rockets* I have been now treating of, require to have *Sticks* fastened to them, to serve them as a Counterpoise, and to assist them in their right Ascent. They are usually made of light dry Wood, such as Pine, Fir, and Lime-Tree. Their Length must be to that of the *Rocket* in a Septuple, or at most an Octuple Proportion; that is, they are commonly 7 or 8 times as long as the *Rocket*. They ought to be of a tolerable Thickness at the End to which the *Rocket* is tied, and from thence down to the lower End go gradually tapering to a Point. The necessity there is for them, is not so much on the score of their Figure, as on account of their extreme Equality as to Weight; or the nice *Æquilibrium* which must be observed in fitting them to the several Weights of *Rockets*. Now you will find it no great difficulty to adjust them exactly, if you put the *Stick* at two Finger's Breadth from the Neck of the *Rocket* upon the Edge of a Knife, or upon your Finger, and if in that Situation both Ends are in *Æquilibrio*, you are right; that is, the End to which the *Rocket* is fastened and the other must be exactly parallel to the Horizon, without inclining or wavering to one Side or the other. But if your *Stick* End happens to overbalance, you must pare and diminish it till it comes to an *Æquilibrium* with the *Rocket* End. You have a *Rocket* with its *Stick*

Fig. 60. plainly and curiously represented in *Fig. 60*. *Brechtelius* teaches us a Method (which is easy enough) to find out the proper Length of these *Sticks* in Chap. IX. of the Second Part of his *Pyrotechnics*, as follows: Add one to the Number of *Fingers* that constitute the Length of your *Rocket*, and multiply the Product by the Length of the *Rocket*, and you will

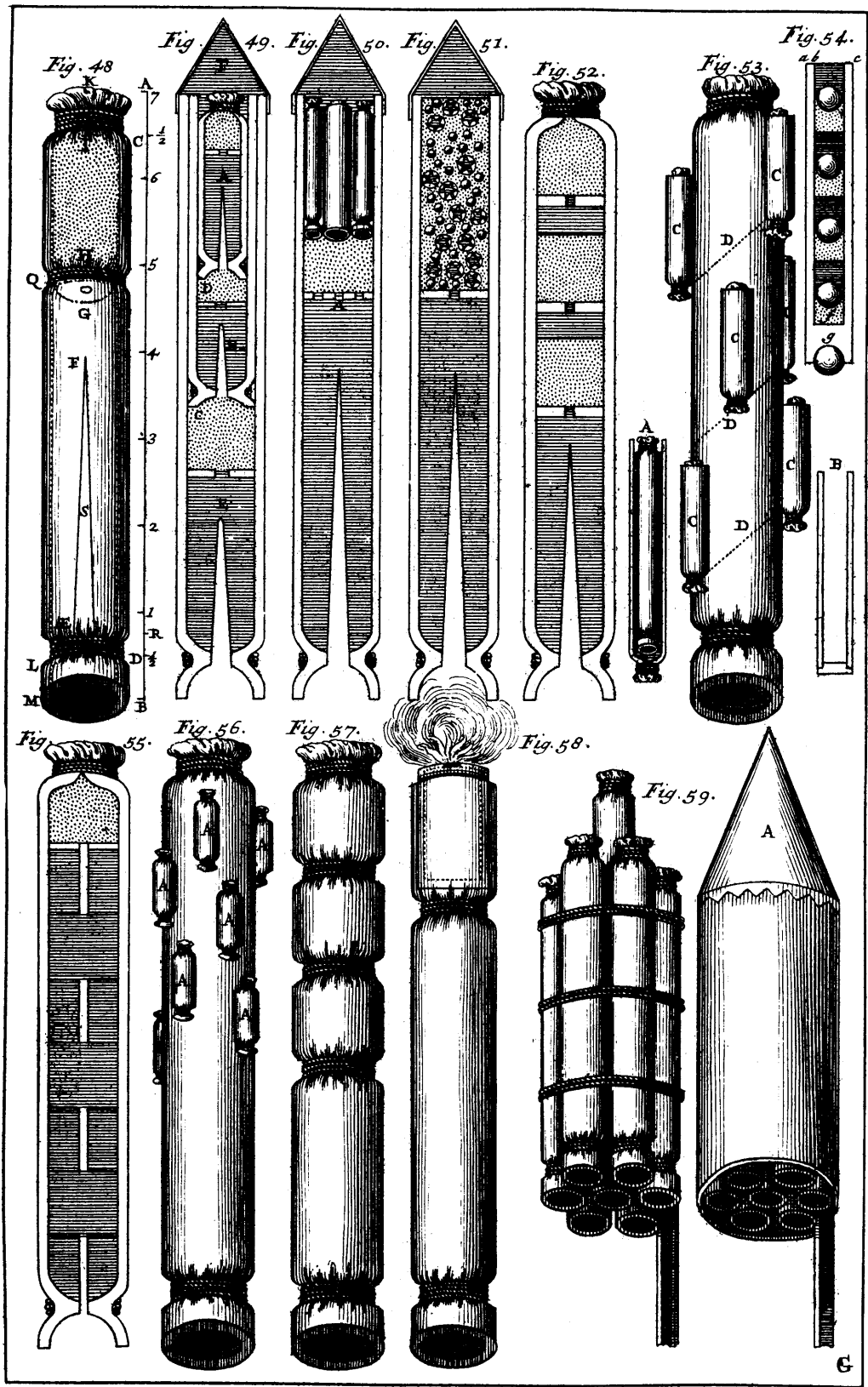

will have the due Length of its *Stick*: For Example; if the *Rocket* is 8 *Fingers* in Length, add 1 to them, and you will have 9; which Number multiplied by 8, which is the Length or Height of the *Rocket*, will give 72. You shall then tye a *Stick* of so many *Fingers* in Length to your *Rocket*.

C H A P. VII.

Of Sky-Rockets that mount up without Sticks.

S O R T I.

TAKE a small *Rocket* of 8, 10, 16, or 18 *Loths*, filled and bored as usual, and fix four small *Wings* to it after the manner of the Feathers of an Arrow: (Letter A in *Fig. 61* will explain what I mean.) *Fig. 61.* These *Wings* must be made of light Wood, such as Lime-tree, or else of PASTEBOARD, and must be placed cross-wise. Their Length shall be $\frac{2}{3}$ of the Length of the *Rocket*, and their Breadth at Bottom shall be $\frac{1}{2}$ of the same Length; their Thickness may be left to your own Discretion: Nevertheless if you would have it in some sort proportionable to their Length and Breadth, it shall be of $\frac{1}{2}$ or $\frac{1}{3}$ of the Diameter of the *Rocket*.

In *Fig. 63* I have given you the Representation of a little Contrivance *Fig. 63.* composed of 4 Rods, a Bottom, and an Handle beneath, upon which you may set this sort of *Rockets* when you fire them. It needs no farther Explanation, since it may be readily understood by the *Figure* itself. In the Middle of the Bottom-Piece, in which the aforementioned Rods are fixed, is a little Cavity or Chamber, that has Communication with a little Channel; the which as well as the Chamber itself must be filled with *Meal Powder*, when you would fire your *Rocket*.

S O R T II.

This kind of *Rocket* differs but little from the former, except that its *Wings* are otherwise contrived; for upon this you have but three only, of the same Thickness with the others, but pretty different from them in Height and Breadth; for the Length of these is equal to the whole Length of the *Rocket* to which they belong, and are fixed upon it in such a manner, that the Lower Extremities of them descend one Diameter below the Neek of the *Rocket*, and consequently their Upper Extremities must fall an equal Portion short of the Head of it. Their Breadth shall be a Semi-Diameter of the Orifice or hollow Cylinder of the *Rocket*, as you may see by a, b. You may, if you please, fire this

T t kind

kind of *Rockets* upon the Contrivance above described, in order to make them fly up with the greater Convenience. See *Fig. 62.*

S O R T III.

Having made a *Rocket* of what Size you please according to the ordinary Method, you shall to the Neck of it fasten a piece of Iron Wyre, with an Iron Bullet at the End of it, of the same Calibre with the *Rocket*: This Wyre shall be turned in a Spiral like a Screw, and shall be as near as possible of such a Length, that in case it happens to widen or stretch a little, the Bullet may notwithstanding be in *Æquilibrio* with the *Rocket*, in the same manner as we just now said of *Wooden Sticks*. *Fig. 64.* will give you a perfect Idea of this.

S O R T IV.

After you have prepared a *Rocket* as you have been fully directed, and that you have covered the *Composition* in it with *Corn Powder* to the Height of one Diameter, fill up the remaining Vacancy with Rasplings or Filings of Lead; observing that the Quantity of it be such, as to be twice the Weight of the *Rocket-Case* it belongs to. Consult *Fig. 65,* which will set you right.

C H A P. VIII.

Of Water-Rockets, or such as Burn and Swim upon the Water.

S O R T I.

YOU shall fill a *Rocket* of 2 or 3 *Loths* with a suitable *Composition*, to the Height that we usually fill common *Rockets*; and fixing a Cap upon the *Composition* with a *Report* of *Corn Powder* above it, it shall be bored throughout the whole Height of the *Composition*. This done, prepare a Paper Cylinder, with two small Wooden or Pastboard Heads or Bases, having a Hole bored through the Center of each. The Height of this Cylinder shall be equal to but half of the *Rocket*, and the Hole through the Center of each Head shall be made to fit the *Rocket* exactly. In short, being nicely fitted, and thrust through the Hole in the Center of each Head of the Cylinder, throw it into a quantity of melted Wax or Pitch; after which the *Rocket* may be fired, and thrown into the *Water*. See *Fig. 66.*

SORTS II, and III.

These Sorts differ very little from the foregoing, whether in Size, or the manner of filling and boring them, or any thing else relating to their Construction. And the only difference between these two, is, that the First (*viz.* Fig. 67) ought to be shut up to the Neck in a Paper Cone, whose Vertex, (as you see in the Figure) or Base, no matter which, is made fast to the Neck of the Rocket. The Second (*viz.*) Fig. 68 is put into a Bladder full of Wind; which must not be dipped in melted Wax or Pitch like other *Water-Rockets*, but only dawbed over with a Liniment, made of *four* Parts of Linseed Oil, *two* Parts of Bole Armoniac, *one* Part of Plume Allum, and *half* a Part of Ashes.

SORT IV.

The *Rocket* which you see represented in Fig. 69, must be prepared after the same manner we ordered with regard to the Ninth Sort of *Sky-Rockets* in Chap. VI. of this Book, excepting that it must not be bored, and that the Orifice of its Choak is very small, which it has in common with other *Water-Rockets*; this is not designed to move upon the Surface of Water, but to burn in one particular Place; and for this Reason there is a Weight tied to the Bottom of it at A. This also must be plunged in melted Wax or Pitch, as well as all the following.

SORT V.

Fig. 70 represents a *Rocket* which is prepared after the same manner with the Third Sort of *Sky-Rocket* in Chap. VI, only with this difference, that its *Composition* is separated by a solid Cap G from certain Sparks and Stars intermixed with *Meal* and *Corn Powder*. To this also belongs a little Iron or Wooden Tube distinguished by B: And from each End of this Tube, there goes another smaller Tube (*viz.*) C D and F E; all three of which have a Communication with one another, and likewise with the *Composition*, and the *Stars*, &c. afore said. The Fire, as soon as ever the *Composition* is burn'd down to the Cap, is conveyed through the aforementioned Tubes to the Head of the *Rocket*, where accending the *Meal* and *Corn Powder*, the *Stars*, (and whatever else might have been in it,) are blown up into the Air. Its Counterpoise may also be seen in Letter A.

SORT VI.

In Fig. 71 you have a *Rocket* that is perfectly like the Sixth Sort of *Sky-Rockets* which we described in Chap. VI; for here the great Boxes

or Cases distinguished by E, and the *Rockets* contained in them by B; and the others of smaller Size, pointed out by D, and the lesser *Rockets* in them by C; stick also to the great *Rocket* A; which communicates *Fire* through the little Tubes H, into the Boxes on each Side of it; which enkindling the *Powder* under the *Rockets* contained in them, blows them up into the Air to perform their Parts. This kind of *Rocket*, together with the *Boxes* or *Cases* on each Side of it, must be wrapped about with strong Paper, as may be seen in G, and then thrown into melted Wax: Nor must you forget to add a Counterpoise under it, that it may burn upright, and float at nearly an equal Height above the *Water*.

S O R T VII.

Fig. 72. The *Rocket* which you have in Fig. 72, has nothing farther in the Preparation of it, than what I directed with regard to the Fourth Sort of *Rockets* in the foregoing Chapter; and all the difference between them, is, that this is not to be bored, as I have already observed; besides its being coated with Wax or Pitch, and burning in the *Water*.

C H A P. IX.

Of Rockets that run upon Lines or Ropes.

S O R T I.

TYE two Iron Rings or a Wooden Tube to a *Rocket* filled with a certain quantity of *Ounces* of a suitable *Composition*, and bored as it ought to be: Then reave through the Rings, or Tube, the *Line* which you would have your *Rocket* to run upon. This is of the most simple kind; for being arrived at the Place, which the Duration of its combustible Matter will allow it to reach, it there stops. The following will be much more artificial. You have a Representation of this in

Fig. 73. Fig. 73.

S O R T II.

Fill any particular *Rocket*, whose Orifice may be equal to that of the foregoing (but much longer) to the Height of 4 Diameters, and bore it to the Depth of $3\frac{1}{2}$. Then upon this *Composition* put a Cap or a little Wooden Partition which must have no Hole through it, and may be glued to the Inside of the *Rocket*, or any other way well secured, to prevent the *Fire*, when it is arrived at that Length, from catching hold of the *Composition* contained in the other Part of the Case. This done,
you

you must charge the Remainder of the *Rocket* to the same Height as before; namely to 4 Diameters; $3\frac{1}{2}$ of which must be bored. You must then choak the *Rocket* at Top, and make a little Receptacle for the Priming as at the other End; or else fit a round piece of Wood to it with an Hole through the Middle of it, as may be seen in A, which must be covered with a little Cap, as you will see distinguished by the same Letter. To this you must add on one Side a Tube made of a very thin Iron Plate, which must be filled with *Meal Powder*. Bore an Hole through the Side of the *Rocket* near the Partition in the Middle, and fill it with *Meal Powder*; which is done, the more readily to convey the *Fire* through the Tube, to the other Receptacle where it lights the *Rocket* at the other End, and consequently obliges it to return back to the Place from whence it came. The upper Part which holds the Priming must be covered with Paper, as well as the small Tube that conveys the *Fire* from one End of the *Rocket* to the other. This shall also have a Wooden Tube, or two little Iron Rings to run upon along the *Line*. You will have the more Diverſion if you tye small Paper *Crackers* all round it. The Contrivance of this *Rocket* is very pretty. You have a Representation of it in *Fig. 74.*

Fig. 74.

SORTS III and IV.

Take two *Rockets* of equal Length, constructed according to the Method we have already laid down, and let them be bound together with strong Packthread, and let the Head of the one be even with the Choak of the other, and so on alternately, to the end that the First of them being burned out to the very End, it may catch hold of the other, and oblige them both to return back again. The extremity by which you intend the first shall fire the other, (that is the Neck of the one and the Head of the other) shall be capped with Paper, or any thing else, as you see in *Fig. A*, minding to fill the Vacancy of the Cap with *slow Composition*. In short, you must add a Tube to them, to run upon. See them represented by *Fig. 75* and *76*, by which you will observe a difference between them; the latter having a piece of Wood hollowed on each Side to receive them both, and keep them at a little distance from one another, in Consideration that if by chance the First should burst, the other may receive no damage from it.

Fig. 75.
and 76.

Observe here that these *Rockets* commonly serve to fire several *Pyroboical Machines* which are used upon Rejoicing Occasions. Sometimes also they are disguised under the Form of divers Animals, whether Fictitious or Real, such as, Flying Dragons, Doves, and other things which you would contrive to vault and run up and down, which we shall treat of in our Book of *Pyroboical Machinery*.

In *Fig. 77, 78* and *79*, you have three Contrivances for hanging up *Sky-Rockets* when they are to be fired.

Fig. 77,
78, 79.

C H A P. X.

Of the several Defects of Rockets. How to avoid them: Together with what ought be observed in the right Construction of them.

THE *First* and most remarkable Vice in *Rockets*, is, when after being fired, and mounted to the Height of 2 or 3 *Perches*, they break and disperse without performing their proper Effects.

The *Second*, which is not much better than the First, is when they remain suspended upon the Nails, waisting slowly away without moving off or rising at all.

The *Third* is, when in their Ascent they form an Arch, or describing a Semi-Circle, return down again to the Ground before all their *Composition* is burn'd out.

The *Fourth* is, when they mount in a Spiral Line, winding up into the Air, without observing an uniform, regular and right Motion as they ought.

The *Fifth* is, when they move up heavily and lazily, as if they refused or scorned to take their Flight.

The *Sixth* is, when the Cases hang empty upon the Nails, and the *Composition* rises and disperses in the Air.

There is still a greater Number of vexatious Accidents, which may frustrate the Hopes, the Labour, and the Expence of the *Pyrobolist*; and which would be too tedious for me here to enumerate. It will be sufficient if you keep an Eye upon these, which are the most to be feared and provided against; and in order to avoid and rectify them, please to observe the following *Rules*.

Infallible Rules for the constructing of Rockets, without any Defect.

1. Your *Rockets* shall have their Heights proportioned to their Orifices or hollow Cylinders, after the manner we have so often repeated.
2. Whether your *Cases* be made of Paper, or Wood, they shall be neither too thick nor too thin.
3. They shall be made of Paper which is moderately dry, neatly rowled, and perfectly tight to the *Bowler*.

4. Their

4. Their Necks shall be well and firmly choaked ; so that neither the Knots of the Cord or Packthread, nor the Folds of the Choak, may dilate or give way ; and therefore they shall be reinforced with Glue.

5. All the *Ingredients* that enter into the *Composition*, being exactly weighed in Proportion to the Orifice or Size of the *Rocket* you intend to make ; shall be first mealed and passed through a Searce seperately : Then weighing them again, they shall be well incorporated together in one Mass, and mealed a second time, and passed through a fine Searce as before.

6. The *Salt-peter* and *Sulphur* shall be purified and mealed as fine as possible : The *Coal* shall be perfectly well burn'd free from Moisture, and made of some light soft Wood, such as Lime-Tree, Hazel, and Branches of Willow : And on the contrary be cautious not to make it of Birch, Oak, Maple and Service-Tree ; because they are naturally impregnated with a great deal of gross Earthy Matter.

7. Your *Composition* shall be prepared just before you want it.

8. It shall be neither too moist nor too dry ; but sprinkled over with a little of some Oily Humour, or a little Brandy.

9. When you drive your *Rockets*, be always mindful to put equal Quantities of *Composition* into your *Cases* at a time.

10. The Strokes of your *Mallet* shall fall in a perpendicular Direction upon the *Driver*.

11. Your *Rockets* must be driven with *Mallets* of proportionable Weight to their Size ; with an uniform Succession, and an equal Number of Strokes every time you pour any *Composition* into the *Cases*.

12. In Paper *Cases* you shall cover your *Composition* with Wooden Caps, with an hollow Convex or Curve Surface ; but for Wooden *Cases* their Convexity shall be plain, that they may be the more firmly secured in the *Rocket*.

13. Your *Rockets* shall be bored with a suitable *Borer*, or *Taper-bit*, so that their hollow Cones may be neither too Wide, nor too Narrow, too Long, nor too Short.

14. The Cavity or hollow Cone shall be as Upright and Perpendicular as possible, and exactly in the Middle of the *Composition* ; so as not in the least to lean to the one Side or the other.

15. You shall not bore your *Rockets* till just before you use them, and when they are bored they shall be tenderly handled, with the ends of your Fingers only, for fear of disordering their Form.

16. Their *Sticks* or *Rods* shall be nicely proportioned to them, both as to Length and Weight, according to the Rule and Method above given. They shall neither be bent nor crooked, uneven nor knotty ; but as strait and as smooth as possible ; and if need be, they may be planed.

17. Your *Rockets* being filled and compleated, take care how you put them into too dry or too damp a Place ; for both the one and the other may spoil them ; therefore chuse some temperate Place.

18. When

18. When you would fire them, they must be suspended upon Nails, perpendicular to the Horizon.

19. You shall not oblige them to move off with Burthens disproportionate to their Strength; and though you are so exact as to load them with futable Weights, the *whole* must be adjusted with regard to Form, so as that it shall with the most Ease cleave the Air, and rise with the least Opposition; so that their Burthens may in no respect retard their Rising, which is a Motion the most unnatural and difficult to any Body. And this you are to observe the more nicely, the larger your *Rockets* are; which must retain in general (as much as possible) a Pyramidical or Conic Figure, as being the best adapted of any Shape whatsoever to pierce the Air, and to meet with the least Resistance from that Element. Tho' I must observe that a Spherical Form is the most convenient for a Body, which is to turn, rowl, and vault in the Air, because of the Equality of its Surface.

20. You shall avoid as much as possible all Rainy, Damp, Misty, and Foggy Nights; as also those which are Tempestuous or Squally.

21. The different Effects produced by several *Rockets*, filled with one and the same *Composition*, must not be attributed to any other Cause, than their not having been treated with equal Diligence in every respect; whether in the Driving or Boring of them, and in many other Articles which ought to be strictly observed. Or else to their having been laid up in Places of different Degrees of Dampness; and having thereupon contracted different Degrees of Moisture, their Flight and Combustion will be various.

22. If you would have them make an Appearance in the Air like *Fire Rain*, or like a Cloud of *Fiery Sparks*, or like long and broad *Rays* darting downwards: You must mix your *Compositions* with a little of Glass coarsely powdered, of Filings of Iron, or Sawduft of Wood. You may also contrive so as to have the *Fires* issuing from your *Rockets* of divers Colours. As for Example; if you mix a certain Quantity of *Campfire* in your *Composition*, it will yield a White, Pale, or Milky-Colour *Fire*. If you mix a little *Greek Pitch* in it, it will produce a Reddish Copper-Colour Flame. If *Sulphur*, you will have a Blue *Fire*. If *Sal Armoniac*, it will be Greenish. If Crude Antimony, the Flame will be of a sad Yellow, or of an Honey or Box-Colour. If the Scrapings of *Ivory*, it will be of a bright Silver-Colour, inclining a little to the Livid or Lead-Colour. If the Raspings of *Yellow Amber*, it will appear the same, but inclining to the Citronish. In short, if you mix your *Composition* with common *Pitch*, your *Rocket* will cast forth an obscure gloomy *Fire*, or rather a black thick Smoke which will darken all the Air. The *Sieur de la Porte* (sometimes called *Baptista Porta*) tells us in his *Natural Magic*, Book VII, and Chap. VII, that the *Loadstone* being buried under Burning Coals, commonly emits a Flame that is of a Blueish, Sulphurine, or Iron Colour. Whosoever doubts this, may make the
Expe-

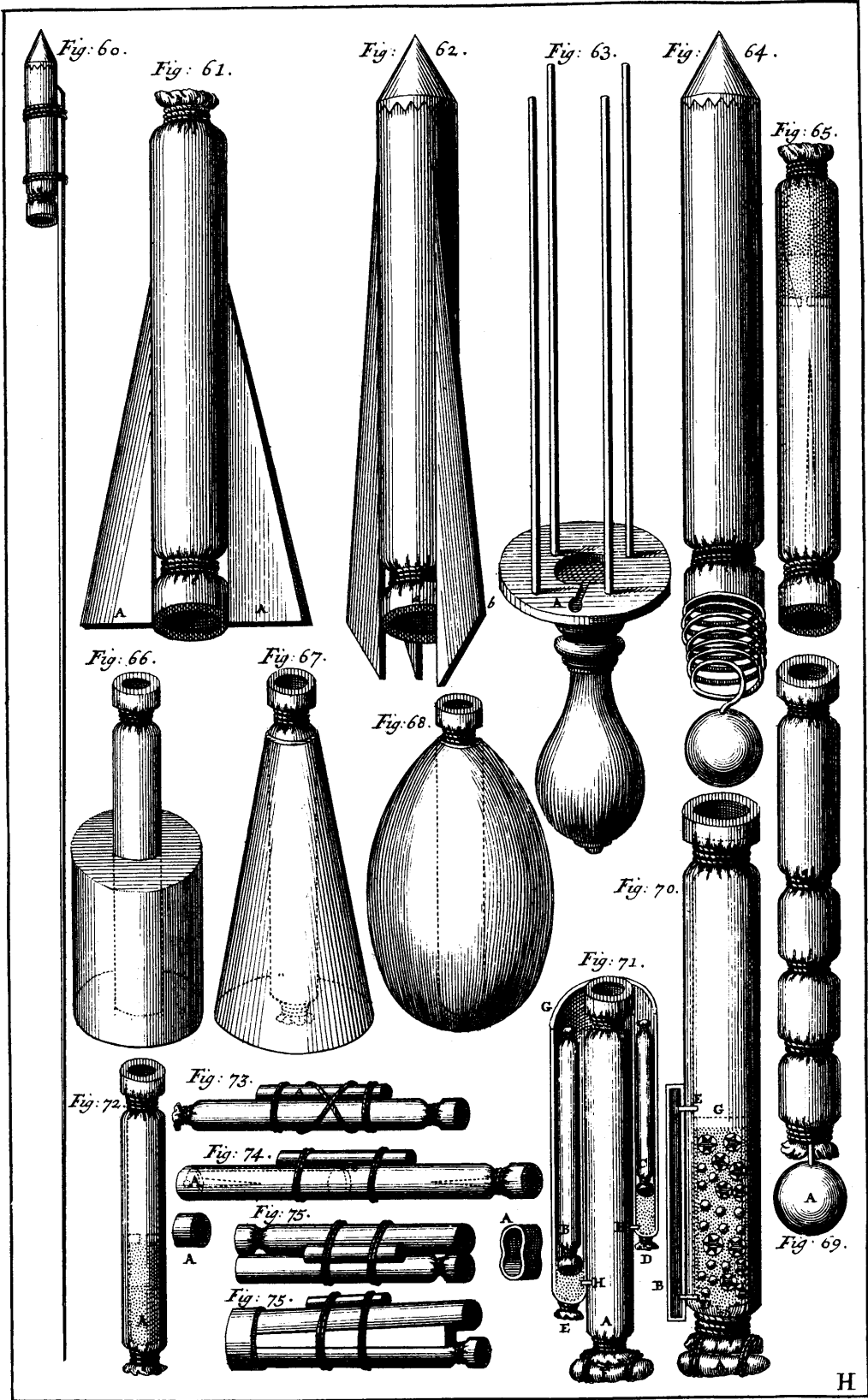

Experiment by scraping a little of it into *Rocket Composition*, and see whether it be as he says or not: But however let him do it with Moderation and sparingly, for fear lest a disproportionate Quantity of it should deceive him in some degree or other. But I think, I have now said enough concerning *Rockets*; and I fear, I begin to grow tiresome to the Reader, and that I shall strain his Sight too much, if I keep him any longer looking up to the Sky. And indeed, I apprehend that I have left nothing unsaid that may be of Use to the diligent and expert *Pyrobolist*, and that I have fully warned him, as to what he ought to embrace or fly; what he is to follow or avoid. But before I conclude this Book, I must observe that it is impossible to meet with any Artist so perfect, but that he may err sometimes in some trivial Point, where such a multiplicity of Circumstances must be kept in Mind; therefore we ought not to pass any Judgment upon a *Pyrobolist*, nor infer any thing to his Advantage or Disadvantage, from his good or bad Success in the Construction of *Rockets*. It would be endless to enumerate how many different Accidents may happen in carrying on such ticklish Works (though at first Sight they appear no other than Childish Amusements) or even to tell of what Consequence an almost incomprehensible number of Particulars may be, which *Argus* himself with all the Eyes bestowed on him by Fabulous *Antiquity* (in Allusion to his great Sagacity and Watchfulness) would not be able to keep continual Sight of; much less avoid falling into some little Mistakes, and consequently would be far from providing against them all in general. Therefore all that can be done in this Case, is to take the Advice of good Masters, and to consult able *Pyrotechnicians*, who often lay their Hands to the Work; for I must own and declare, that I make no Account of certain Persons who having no Knowledge in the Practical Part, yet arrogantly take upon them right or wrong to censure the Performances of those who are incomparably more knowing than themselves, with an envious Design of wounding their Reputation, or blasting their Honour, or to instil a mean Opinion of them into those who are sometimes the most interested in the Loss or Conservation of the Persons so decried. But what can we say to these malicious Censors that may affront them less than that Old Saying: *Ne Sutor ultra Crepidam, Let not the Shoemaker judge beyond his Last*. Now the whole Excellence, or universal Knowledge of *Pyrotechnics* doth not consist in the Construction of *Rockets*, which is but the least Part of that great and noble *Art*; and accordingly we find that they are never employed but upon Tumultuous Rejoicings, on the score of Victories obtained, Towns surrendered, or Sieges raised; or sometimes at the Celebration of Marriages, or at Solemn Festivals to divert the Guests; and in short, at public Bonfires exhibited to please the People only. Therefore we must not peremptorily conclude any Man to be well skilled in our *Art* that has a Knack at making *Rockets*; for we find but too many who will

make a *Rocket* well enough; but if you would go any farther with them, they will ask Pardon, and desire to be excused. In truth, it would be an arrant Shame, that such Fellows should assume the fine Title of *Pyrotechnicians*; for with equal justice might a Mountebank, a Country Barber, or a Farrier boast of being a learned Doctor of *Physic*. This then is not the utmost Point of Perfection in our *Art*, and we must believe that there is still something of a more exalted Nature, that properly and positively constitutes the true *Pyrobolist*, who may justly bear the Authentic Denomination of *Master*. All our Inventions, and Fire Machines, together with that variety of Practice which will be exposed to your View in the Sequel of this *Work*, will give you a just Idea of the *Perfect Pyrotechnician*. I say then, again and again, for several Reasons, that it is impossible to deduce any Consequence to the Disadvantage of the other Parts of this *Great Art*, from the regular or irregular Ascent of *Sky-Rockets*; as was practised by the *Magicians* of old, who drew Conjectures with regard to Human Events from the Flight of Birds; and consequently that we ought not rashly (as I have already intimated) to condemn those, who happen ever to be unsuccessful in the Construction of *Rockets*. What I have here said is grounded upon sufficient Reasons, and is a real Fact; for I knew in my Time a *Master* of the *Ordnance* to a great Prince (whose Name I shall forbear here, tho' he has never spared mine) who thought there could be none more able in the *Pyroboic Art*, than those who were well skilled in making *Rockets*; and accordingly not contented with caressing them and receiving them with open Arms, and admitting them into the Service of his Prince, and placing them in the Rank of *Pyrobolists*; he by all his Endeavours fixed them deeply in the Favour of his Master, and continually represented to him, the Necessity there was, for that incomparable Knowledge they had in their *Art*. But he has since then perhaps been convinced (if he would be convinced; tho' at the Public Expence, and not at his own) that *Rockets* are in reality no other than Amusements; Inventions more properly calculated for the Diversion of People who would spend their Lives in Debauchery and Dissoluteness, than the true Thunder of War. And indeed he found by Experience that they were not even sufficient to shake the Enemy, much less to put them into Disorder; and that those whom he had, with so much Care, taught to make *Rockets*, were not only incapable of managing any Warlike Machine with Skill and Judgment, at a Time when they were to tear the Enemy to Pieces; but also unworthy of the Title which he had too readily and liberally bestowed on them. As for himself, the *Story* says that not being able, or not daring to be present on the Spot, he was at a Place 40 *Miles* from thence whilst the *Tragedy* was acting; and afterwards found in a snug Corner out of all Danger, and meditating this fine Saying in his Heart: *Beatus qui procul Negotiis*. *Happy the Man who is out of Harms-way.*

But

But God give him Grace to amend himself; so that laying aside (if Shame does not prevent him) the Title and Office of Master, he may humble himself, and submit to the *Ferula* of good and expert Professors in our *Art*, and under them serve a commendable Apprentiship; receiving their Counsel no longer as impertinent or troublesome Corrections, but as useful Instructions towards the regaining of his Reputation, and the re-establishing his Honour. As for those *worthy Gentlemen* his Disciples, who once embraced his Instructions with such Warmth, and looked upon whatever he said as pure Oracles; I beg of them to know themselves at last, and renouncing their false Doctrine, to think of pursuing more rational Schemes for the future, towards the Advancement of their Fortunes. But as it is impossible to recall what is past, and since it is *Sending for the Physician after the Man is dead*, to say any thing more about this matter; I shall only add that I believe this celebrated Doctor would pretty well cure his own particular Infirmity, and apply a Remedy to the Damage he has done to so many deserving Persons, if he for the future would continually keep in his Heart and in his Mouth these Words of the Prince of Orators: *Tibi semitam non sapiſ & alteri monſtras viam. Thou thyself art blind, and yet wouldest guide others.*

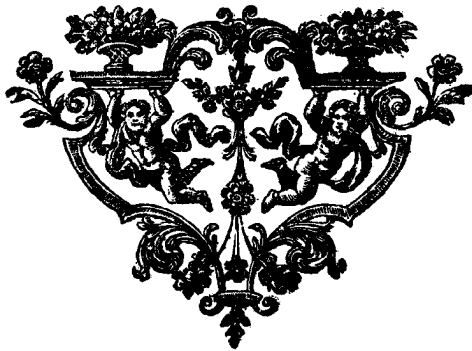



OF THE
GREAT ART
OF
ARTILLERY.

PART *the* FIRST.

BOOK IV.

Of FIRE GLOBES or BALLS.

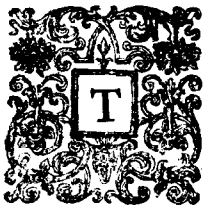

THE Word *Globe* is of a more extensive Signification, and what we mean by it is much more various as to Form in *Pyrotechnics* than in *Geometry*; for you must not here think that *Globes* or *Balls* are perfectly Round Bodies, and contained under one Surface, according to *Euclid's* Definition of the *Globe* and *Sphere* Book XI. Defin. XIV: but that we in general understand by it, several Bodies of various Kinds of Figure, all distinct and different from one another. For first, there are those which are perfectly Round, some of which are Solid and others Hollow; of the former are all *Cannon* and *Musquet Balls*, &c. and of the latter are *Grenado's* and *Bombs*, &c. which are several ways filled according to the Rules of *Pyroboly*. There are again *Balls* made in the Fashion of an Egg; others of a Spheroid; some in Form of a Citron or Pear, or a Cylinder, and in several other Shapes which the Workman may give them. Besides these of simple Kinds of Figure, there are others compounded, that is, that partake of several sorts of Form together. And what is still farther extraordinary, I have in the Magazines of the Earl of *Oldenburg*, and in several other Places, seen very old *Grenado's* that were shaped perfectly like a Cube or Paralleloiped. Now let their Qualities and Conditions

be

be what they will, and whatever Form or Figure they may bear, I beg the Liberty of calling them by the general Denomination of *Fire Globes* or *Balls*; at the same time observing to give them Sirnames and Epithets futable to their particular Properties and Effects, to distinguish them the better from one another. This is the Subject I propose to entertain you with in this Book, which we will divide into Two *Parts*. In the *First* of which we shall shew you, and as it were make you handle (without any danger of burning your Fingers) all the Sorts of *Recreative Fire-Balls* both *Aquatic* and *Terrestrial*, or such as run and leap upon Horizontal Planes; and those also which are projected from Mortars, which because they perform their Parts in the Air may be properly enough called *Aerial*. The *Second Part* of this Book shall treat of all those *Balls* which we call *Serious* or *Military*; that is, of all those that are used upon Warlike Occasions, as well to repel and oppose the Assaults of the Enemy, as to convey Fire and Dread into their Quarters, whenever it is needful. I hope it will not be taken amiss that I here give the first Place to the *Recreative Fire-Balls*; for in so doing I only imitate Nature, who first forms the *Fætus* in the Womb, which from Infancy advancing by degrees to Puerility, is thence gradually conducted to Virility, and at length compleated in perfect Manhood. These *Recreative Works* of our *Art* are but the first Fruits, or rather the Seeds which produce the many fine Fruits of this noble *Science*. They are as it were the Lower Rounds of a great Ladder to the Highest of which none must hope to arrive: Or to lay aside the *Allegory*, and speak in direct Terms; none must expect to attain a thorough Knowledge of what concerns the terrible and wonderful Machines of War, but Those of a fertile Genius, a robust Body, and of an Intrepidity not to be shaken by the horrid Bellowing of Cannon, nor dismayed at the Tempestuous Iron Hail projected from those merciless Thunderers. But let us have done with this, and take in hand the Subject we proposed to treat of in this Book.

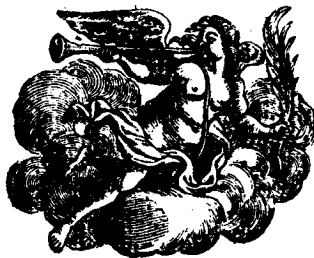



PART I. of this BOOK.

CONCERNING

RECREATIVE GLOBES.

C H A P. I.

Of Aquatic Globes, or such as Burn and Swim upon the Water.

S O R T I.



Fig. 80.

LET an hollow Wooden *Globe* made of what Size you think fit, and let both its Convex and Concave Surface be perfectly Spherical: The Thickness of the Wood throughout shall be $\frac{1}{2}$ of the Diameter A B, as you see in A C, or B D; and shall be furnished by a Cylinder, whose Diameter E F shall be $\frac{1}{2}$ of the Diameter A B, and the Hollow of it G H shall not exceed $\frac{1}{2}$ of a Diameter aforesaid. The opposite part of this *Globe* shall be opened, to receive a Tompion I K, of the same Diameter with the above Cylinder; by which Opening, the *Composition* must be put into the *Globe* when you would fill it; and through which you have the conveniency of putting a *Petard* or *Report* made of an Iron Plate in a Cylindrical Form, and which being filled with good *Corn Powder*, must be laid athwart as you see in M. The *Globe* being thus prepared, shall be filled with one of the *Aquatic Compositions*, which we shall hereafter treat of, and then stopped up with a Tompion that has been steeped in hot Pitch. This done, you shall run as much melted Lead over it as may be sufficient to make it of equal Weight, or something heavier than a Bulk of Water of the same Magnitude with itself. I shall tell you why this is done towards the End of this Chapter. In short, this *Ball* being adjusted after this manner, it shall be thrown into melted Pitch. When you would divert yourself with it, light the Priming, and as soon as you find, that the *Composition* is thoroughly inkindled throw it into the *Water*. Fig. 80 represents this,

S O R T

S O R T II.

This *Ball*, which you see represented in *Fig. 81*, differs from the a-*Fig. 81*. bovementioned no farther, than that the Form of it is not Spherical but Spheroidal; and the Section parallel to the Axis of it is Oblong. The Thickness of the Wood throughout the whole, its Tompion beneath and its Vent-hole B, observe the very same Proportions as in the above-described *Globe*. Beneath it you have a Leaden Grenade distinguished by A, charged with *Corn Powder*, the Neck or Fuze of which goes into the Bottom of the *Globe*, as the *Figure* shews you. In short, it must be filled with one of the *Aquatic Compositions* I shall hereafter give you; and then well coated with Pitch, before it is thrown into the Water.

S O R T III.

You shall get an hollow Wooden Cylinder, made by a Turner, of the *Fig. 82*. Height A D or B C, which shall be $1\frac{1}{2}$ of the Breadth A B or D C; it shall at Top be stopp'd up with a Wooden Tompion with an Hole in the Middle of it, of a Conic Form to hold the Priming, the inferior Breadth of which E F, shall be $\frac{2}{3}$ of the Height of the *Globe*, and the superior Breadth of it G H, $\frac{1}{2}$ of the Inferior. You shall fill it with one of the *Compositions* I shall hereafter give you, and stop it well up with a Tompion, after having wrapp'd it round with a piece of Cloth dipped in hot Pitch or Tar; beneath it you may fix a *Grenade*, or a *Report*, as you see in M. The whole being thus ordered, you shall near the Vent-hole fix an *Æolipile*, as you see in L, which is to be contrived after the following Method. Get a Founder to cast you a small hollow *Globe*, (or it may be of any other Form if you will) or else you may make it by foldering two Hemispheres together; from the Top of it shall issue two hollow tapering Pipes like Horns, but let their Cavities be as small as you can possibly make them, especially towards the Extremities of them; in short, their Diameters may be equal to $\frac{1}{2}$ the Diameter of the Substance of their respective Pipes. Being thus adjusted, cover it with *Burning Coals*, and let it there remain till it is red hot: Take it burning as it is, and put the small Pipes of it instantly into Water, and let them be immerf'd a little till the *Æolipile* is quite cold; during which time it will have imbibed a certain Quantity of Water, more or less according to the Bigness of it. This *Ball* or *Æolipile* being ordered as we have now directed, you shall secure it fast near the Vent-hole of the *Water-Globe* with small Nails or Pins running through a little Handle adjoining to the Lower Part of it. This done, you shall fix two small Leaden Flutes or Tubes on each side of your *Water-Globe*, such as you see in I and K (in the same *Figure*) so contrived that their Upper Orifices may exactly fit the Extremities of the Pipes of the *Æolipile*. Having done

all this set fire to the Priming with the End of a Match, and when the *Composition* is accended and got to a strong Head, throw it into the Water; and in a little time the *Fire* issuing from the Vent heating the *Æoli-pile* to that degree as to make the Water in it boil, it will discharge its Steam through the small Pipes with great Violence, which rushing into the Flutes above-mention'd, they will yield an odd kind of Harmony.

Fig. 82. *Fig. 82* will give you an exact Idea of this.

S O R T IV.

Fig. 83. In *Fig. 83* you have the Representation of a *Water-Globe*, which the *Germans* call *Binschwerm*. This needs no particular Description to illustrate it, for the *Figure* explains itself. The Height of this *Globe* shall be proportioned to the *Running Rockets* it is designed to contain, tho' it is generally made $1 \frac{1}{2}$ as long as it is broad. The Wooden Tube distinguished by A, ought to be equal in Height to the *Globe*; and shall be filled with a *Composition* of 3 Parts of *Powder*, 2 of *Saltpeter*, and one of *Sulphur*. You again, are to add underneath it a Paper *Cracker*, as you see in C; D is a piece of Lead serving for a Counterpoise; in short, you must add a round piece of Board to buoy it up upon the Water, a *Profil* of which is represented by B.

S O R T S V, and VI.

Fig. 84. and 85. In *Fig. 84* and *85* I present you with the Construction of two *Water-Globes*, which have a near resemblance to one another as to Effect, but very little Affinity to each other as to Form. In the *First* of these, the Middle of it A, is filled with an *Aquatic Composition*, which must be stopped up with a Wooden Tompion as you see in H; which must be pierced through and through in the Middle to receive the Priming. In B and C you have certain Hollows or little Receptacles for holding small and great *Rockets*. The Letters E and D point out the small Tubes of Communication, through which the *Fire* is conveyed to the *Rockets*. F is an Hole through which the *Fire* has Passage to the Leaden *Grenade*, or a *Cracker*, one of which we usually fasten to the Bottom. So much for the *First Figure*, proceed we now to the *Second*. You are to fill the Middle of this, as well as that of the former, with an *Aquatic Composition*, as you see in A. This *Globe* incloses two Orders or Sorts of *Rockets* (*viz.*) Greater as B, and Smaller as C. The two Tubes which convey the *Fire* from the Body of the *Globe* to the two *Rockets* are denoted by H and N. D is a *Report* of *Corn Powder*, which is separated from the *Composition* by the Wooden Partition E, which has an Hole bored through the Middle of it. Farthermore F is a Cap that covers the *Composition*, which is in like manner perforated in G, where you are to set *Fire* to the Whole. You may make Covers or Heads of
pasted

paſted Paper, or of Canvaſs dipped in Glue, and ſometimes made of an Iron Plate, with which you cover the Tubes M and N, which hold the *Running Rockets*, in order to hide them. In ſhort, O and P are two Cavities or Grooves which are to be filled with *Meal Powder*, to fire the *Rockets* which are placed over them. The *Profil* of this will fully inſtruct you.

S O R T VII.

Get a Wooden *Globe* that is perfectly Round and Hollow within, and Fig. 86. pierce the Outside of it with certain Cavities, of ſufficient Capacity to receive a *Running Rocket*; however take care that they be not made ſo deep, but that there be the Thickneſs of a Finger of the Wood, between the inner Extremities of them and the *Aquatic Compoſition*, contained in the Middle of the *Globe* A. That the aforeſaid *Compoſition* may have a Communication with the *Rockets* which are thruſt into the Cavities above mentioned, you ſhall bore the Wood between them with a fine Gimblet, or with a red hot Iron Pin, juſt as you ſee in B; which Hole ſhall be filled with *Meal Powder*. This done, the *Vertex* of the *Globe* ſhall be ſurmounted by a Wooden Cylinder or Tompion, crowned with the Hemisphere C, made hollow to receive the Priming. In the oppoſite Part or Bottom is a Tompion D, which is likewiſe hollow to give Paſſage to the Fire, that it may enkindle a *Cracker* which we commonly fix beneath it. In ſhort, E points out a Leaden Counterpoife which is deſigned to keep the whole upright in the Water. See Fig. 86.

S O R T VIII.

The Form of the *Globe* in Fig. 87 is not Simple in its Conſtruction Fig. 87. like the foregoing, but is pretty Complex; for its Lower Part is an hollowed Cylinder, which is ſurmounted by a Concave Hemisphere as G. The Cylindrical Part is filled with *Paper Crackers* as C, and the Hemifpherical Part with an *Aquatic Compoſition* as may be ſeen in A. This *Compoſition* is ſeparated from the *Crackers* by a Wooden Partition D; through which paſſes a Wooden Tube as B, whoſe lower Extremity muſt fall ſhort of the Bottom of the *Globe*. This Tube muſt be filled with ſuch a *Compoſition* as I preſcribed for the Fourth Sort of *Globes*. Beneath all, is a *Paper Cracker* as E, and a Leaden Counterpoife as F. H is the Vent-hole, where you muſt prime your *Globe* in order to fire it.

S O R T IX.

The *Water-Globe* you ſee in Fig. 88 is a Spheroid, though you may Fig. 88. have it perfectly Round if you will. The Body of this muſt be filled with one of the *Compoſitions* we ſhall hereafter give you. The Outside

or Convex Surface of it is fluted or hollowed in several Places, for the more conveniently fixing of *Crackers* to it. These are distinguished by the Letter A. On one Side of the *Figure* in Letter E, you have the Form of these *Crackers*, which are to be laid in the above-mentioned Flutings, to each of which belongs a little Iron or Copper Fuze, which must be filled with *Meal Powder*, and so ordered as to fit the small Holes you see in the Flutings, and which are distinguished by B. Through these the *Fire* has a Communication from the Body of the *Ball* to the *Crackers*. F points out the little Fuzes before-mentioned, and shews how they are to be fixed to the *Crackers*. C is the upper Orifice for the Priming. In short, D is its hollow Tompion, through which the *Fire* is communicated to the Whole.

S O R T X.

Fig. 89. As for the Construction of the *Globe* Fig. 89, you will readily conceive it; the *Figure* explaining itself; therefore I shall not trouble you with a particular Detail of it. I shall only observe that the little Chamber A at Bottom ought to be $\frac{1}{2}$ of the Breadth of the whole *Globe*, and that its Height should be $1\frac{1}{2}$ of its Breadth. Secondly, that the *Water-Ball* B, shall be as we ordered in the First Sort, and on all Sides encompassed with an *Aquatic Composition* as may be seen by H. That the Chamber A shall be covered by the Partition C, to the end that when the *Powder* in it shall have the *Fire* conveyed to it, through the Pipes or Tubes E, F and G, it may with the more Ease and Force blow up the *Ball* in the Belly of the First; which taking fire at the Hole D, will burn upon the Water, and will soon after to the Astonishment of the Beholders blow up the other *Ball* that was in it. In fine, I must caution you to secure the piece of Wood that covers the Whole as well as possible, for fear it should be blown up by the *Composition* of the greater *Globe* before it is all burned out.

S O R T XI.

Fig. 90. If you consider the *Globe* represented in Fig. 90 as to its Effect, you will find that it has a perfect Resemblance with that we have been just now describing; except that instead of containing a Spherical *Globe* in its Cavity, it has Iron *Petards* or *Crackers*, as may be seen by the Letters B and F; besides that it retains the Form of a Cylinder, and is flat both at Top and Bottom. Above the *Crackers* it is filled with an *Aquatic Composition*, like that above described, as may be seen by A. The Tube C which goes through the Body of it, and touches the Matter contained in the Chamber D; ought to be filled with such a *Composition*, as we directed for the Fourth Sort of these *Globes*. Near the Lower Extremity of this Tube you shall bore an Hole as E; by which the *Fire* may have Passage

sage to the *Crackers* when the *Globe* is blown up. In short, the Chamber D in the Part where it is broadest ought to be $\frac{1}{2}$ of the Breadth of the whole *Globe* itself, its Height shall be $\frac{1}{2}$, but underneath it will be sufficient if it is $\frac{1}{2}$ of the aforementioned Breadth. G is a *Paper Cracker* which is made fast beneath all. H is a little Communication between the Chamber and Cracker.

S O R T XII.

As to the Construction of the following *Globe* (Fig. 91.) You first must Fig. 91. have an hollow Wooden Cylinder made, having in the Bottom of it a Chamber which may be filled with *Powder*: Its Orifice shall be at least one Foot in Diameter, and its Height $1\frac{1}{2}$ of its Orifice. Being thus, you shall adjust a round Board whose Convexity may exactly fit the Concavity of the *Globe*, and freely slip down into it: Beneath this Board shall be a Wooden Tompion to confine the *Powder* in the Chamber, and through this Tompion shall pass an Iron Tube filled with *Meal Powder*, or with that *Composition* we mentioned for the Fourth Sort of these *Balls*. You will see the Representation of all this in the *Figure* under the Letters A, B, C, D, E. In the Third Place you shall prepare 6 *Water-Balls* or more, as you shall think proper, of the same Form as we described in the First and Second Sorts; or any of the foregoing, each of which shall have an Iron Fuze in its Orifice filled with good *Meal Powder*. Let all these *Balls* be of such a Size, that being disposed in a circular Form, and joined close to one another, the imaginary Circle they are contained in, may not exceed the inner Circumference of the great *Globe*, in which you would lodge them, that is, that they must as exactly fit each other as possible. This done, and having charged the Chamber of the *Globe* with *Corn Powder*, you shall let down the round Board with its Tompion before mentioned into the *Globe*, and upon that you shall range in a perpendicular Situation the 6 *Water-Balls* all round the Iron Tube; which *Water-Balls* must be surmounted by another round Board, with 6 Holes bored through it, which must exactly fit the Fuzes in the Orifices or Vents of the said *Balls*, and be at such distances as nicely to correspond with the same Fuzes; which running up through them shall rise a little above the said Board. The better to conceive this, cast your Eyes upon the *Figure* at the Letter G. This last Board or Partition shall be spread over with a good Quantity of *Meal* and *Corn Powder* mixed together, and upon that shall be placed as many *Running Rockets* as the *Globe* can hold. In the midst of these shall be fixed a large *Rocket* (which must not be bored) into whose Orifice the Iron Tube (before mentioned) beneath may enter; this Tube is the same which you see in H; and shall be pierced through and through all round, upon the Plane of the aforesaid Partition; to the end that the *Fire* having a Communication through them it may accend the *Running Rockets*, and

at

at the same time inflame the *Water-Balls* whose Fuzes rise up through the Partition; and from thence, after having penetrated down to the Chamber beneath, it may be sprung, and blow up the Whole into the Air; and make itself be heard. In this *Figure* the Letter F points out the 6 *Water-Balls*, K the Great *Rocket* in the midst of the *Running* ones; L the Chamber for the *Powder*; M is a Communication to convey the *Fire* to the Paper *Cracker* N. In short, this *Globe* being adjusted after the manner we have now directed, it shall be well cased and envelopped with a proper Covering, and thrown into Tar to preserve it from the Water.

S O R T XIII.

The *Water-Globe* I am now going to describe, and which is represented in *Fig. 92.* is by the *Germans* called *Wasser Pumpe*, by which they mean a Pump or Pipe, or any such Hydraulic Contrivance; they again call it *Wasser Morser*, which signifies an *Aquatic Mortar-Piece*, or a *Mortar* that will serve upon the Water; and is to be constructed after this manner. Take seven Wooden Pipes or Tubes, and wrap them round together, with a Tarred, Pitched or Glued Cloth, and gird them firmly round with Cord or Mar-line. Their Height, Breadth and Thickness of their Wood, may be ordered as you shall think proper; except that you must allow the Middle one a somewhat greater Height than the rest: These Tubes then (having the highest in the Middle of them) shall be bound up together in one Cylindrical Body, as may be seen in D. Beneath the inferior Extremities of them you shall fix, (by way of Base or Bottom) a round piece of Board as you see in C, to which you shall fasten these Tubes with small Nails; and be not sparing of Glue to stop up all the Cracks or Crevices to prevent the *Composition* from taking Air. This done, you shall fill your Tubes according to the Order you may observe in *Fig. A.* First you shall pour into each of them a little *Corn Powder*, to the Height of about half an Inch; and upon that, put a *Water-Ball* as you see in G; upon that, *slow Composition*; and then *Corn Powder* again; and then a *Water-Globe* filled with *Running Rockets*, as may be seen in H; and upon that again *slow Composition*, then *Corn Powder*, and then a *Light Ball* as may be seen in I. Over this you shall a third time put *slow Composition* and *Corn Powder* as before, which shall be covered with a Wooden Cap: Upon this Cap you shall set *Running Rockets*, but not so closely together, but there may be room between them for a Wooden Case filled with an *Aquatic Composition*. In short, to conclude, you shall fill the Remainder of the Tubes with *slow Composition*, and then stop them well up. All your Tubes being filled after this manner, you shall get a square or round piece of Wood, no matter which, with an Hole in the Middle of it, big enough to receive the Ends of all these Tubes thus bound together, which you shall stop near the Tops of them to buoy them up, and preserve the *Powder* or *Compositions* from being Wet.

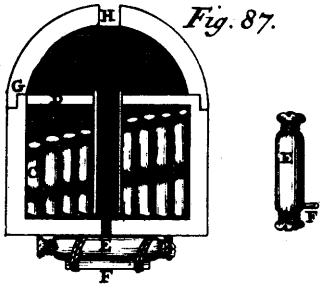
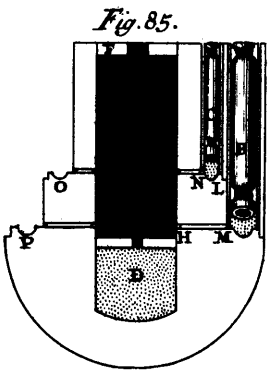
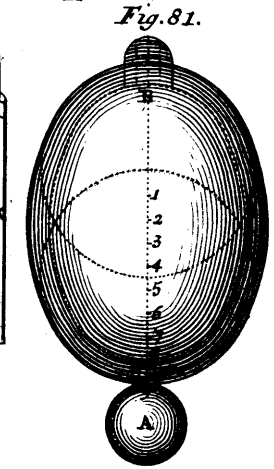
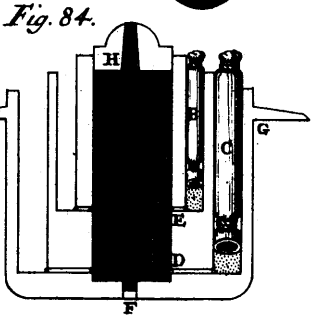
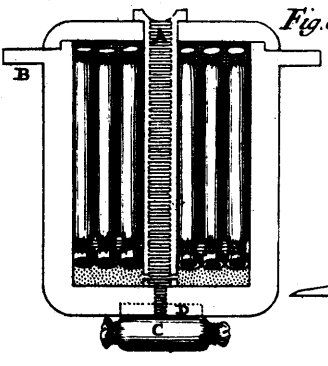
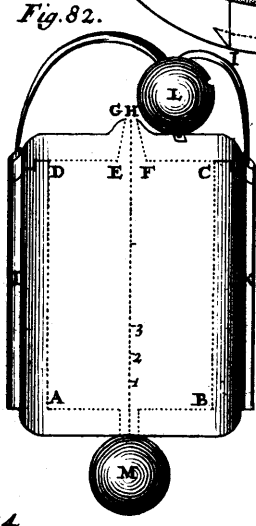
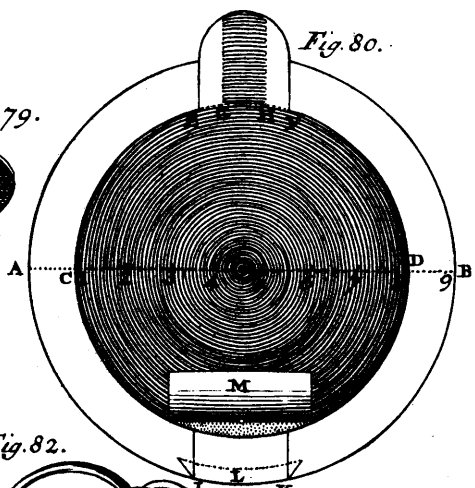

Wet. This Float-Board is distinguished by the Letter L. The whole being prepared pursuant to the Directions here given shall be dipped into a Quantity of Tar. Then shall the *Rocket M* be stuck into the Orifice of the Middle Tube, or instead of it, a small Wooden Tube filled with a strong *Composition*, and that will burn upon the Water (as I have so often mentioned) which is the same with the *Composition I* ordered for the Fourth Sort of *Balls*. As to any thing farther relating to this you may readily trace it out from the *Scenographical Figure*, which we have here drawn.

Observe here in the First Place, that it is necessary that the Middle Tube should have a little more *slow Composition* in it than those which encompass it.

In the Second Place, take Notice that if you would have all these Collateral Tubes take *Fire* at once, you must pierce the Sides of the Great one with small Holes, each of which shall correspond with one of the Tubes, by which means the *Fire* may be conveyed to all of them at once, and consume them equally and in the same time. But if you would not have such a quick Consumption of them, but on the contrary would have the Pleasure of seeing them burn one after another, you must head them well up with strong Paper, and to each Tube fix a little Pipe of Communication, filled with *Meal Powder* or a *slow Composition*, through which the *Fire* may be conveyed from the Bottom of that which is consumed, to the Orifice of that next to it, and so on successively to such as have not been fired.

C O R O L L A R Y I.

Of Odoriferous, or Perfumed Water-Balls.

GET a *Turner* to make you some hollow *Balls* of the Bigness of a Walnut or Crab, which you shall fill with one of the following *Compositions*: Being all ready and filled, you shall, after having lighted them, throw them into Water; (this I understand to be done in some Room or Apartment) but first you shall add a little *quick Match* to them made of our *Pyrotechnic Tow*, or Cotton Wyck, that the *Composition* may be lighted the more conveniently. These *Compositions* are as follow:

Take of *Salt-peter* ζ iiij, of *Storax Calamita* ζ j, of *Frankincense* ζ j, of *Mastic* ζ j, of *Amber* ζ ss, of *Civet* ζ ss, of Sawdust of *Juniper* ζ ij, of Sawdust of *Cypress* ζ ij, and *Oil of Spikenard* ζ j; make your *Composition* of these according to Art and the Method laid down.

Or else take of *Salt-peter* ζ ij, of Flower of *Sulphur* or *Brimstone* ζ j, of *Campfire* ζ ss; of the Rasplings of *Yellow Amber* finely pulverized ζ ss;

of Coal of *Lime-Tree-Wood* $\frac{3}{4}$ j; of *Flowers of Benjamin* or *Affa Odorata* $\frac{3}{4}$ fs. Let them be finely pulverized, then mixed and incorporated together.

C O R O L L A R Y II.

Of the Compositions for Water-Globes or Balls, which burn as well upon the Water as in it.

I.

FIRST take of *Salt peter* finely mealed 16 lb; of *Sulphur* 4 lb; of the Sawings of Wood that have been previously boiled in a Saltpetrous *Lye* or *Water*, then dried, 4 lb; of good *Corn Powder* lb fs; of the Shavings of *Ivory* $\frac{3}{4}$ iij.

II.

Take of *Salt peter* 6 lb; of *Sulphur* 3 lb; of *Meal Powder* 1 lb; of the Filings of *Iron* or of *Hammer-flaw* 2 lb; and of *Greek Pitch* lb fs.

III.

Take of *Salt peter* 24 lb; of *Meal Powder* 4 lb; of *Sulphur* 12 lb; of *Sawdust* 8 lb; of *Amber Powder* lb fs; of *Glass* coarsely powdered lb fs; of *Camphire* lb fs.

You must observe the very same Rules in the Preparation of these *Compositions*, as we taught with regard to those designed for *Rockets*; except that the *Ingredients* need not be so finely mealed, but they must be to the full as well mixed and incorporated. You must take care that your *Composition* be not too dry when you would fill your *Globes*; and for this Reason it shall be moistened with a little of the Oils of *Linseed*, *Olives*, *Naptha* or *Petrol*, *Hempseed* or of *Nut*, or any other Fat Substance that is susceptible of *Fire*.

Besides the *Aquatic Compositions* above-given, from my own Experience, you may contrive others at pleasure, by observing to take the *Ingredients* in different Proportions to one another. This indeed you will find easy enough; but I would have you try them from time to time, before you exhibit them publickly. It will be of very great Importance to such as would have a perfect Knowledge of the Nature of *Compositions*, to be extremely well acquainted with the particular Virtues, Properties and Effects of each *Ingredient* they are composed of; for as *Aristotle* saith in *Lib. VII. Cap. X.* of his *Physics*, *Ex particularibus præcognitis universalis acquiritur Scientia: The Knowledge of particular Things leads us to universal Science: Therefore I must desire you to consider attentively what I am going to say to you of all these Ingredients* separately.

Gun-powder is the First and Principal of them all, the most violent when accended, and burning more outrageously than any of the rest: Whence it is that it powerfully resists all kind of *Moisture* to prevent its Flame from being suppressed by it.

Saltpeter well purified may be placed in the Second Rank. We have treated largely of this when we had occasion to speak of its Nature and incredible Virtues in *Gun-powder*: But besides what we have said of it, we shall add, that it has an unaccountable, particular Quality, of repelling and dispersing the Drops of Water which present themselves near the Orifices of *Water-Globes*, &c. which must be owing to its *Windy Expansion*.

All *Oils* mixed with the *Compositions* in moistening them, when they are well united with the other *Ingredients*, keep up the *Fire* in spite of the Water, and seem to side with it to prevent its Extinction; and this because of a Fat Humour, together with a very Aerial and Igneous Substance natural to them, which the *Fire* embraces with such Eagerness that it is impossible for them to disengage themselves from that Element, when once caught hold on by it; and as all *Oils* are of a pretty dense and tenacious Substance, and their Parts not to be disjoined or dispersed easily, it is a hard matter for *Water* to dispossess the *Fire*, when thoroughly possessed of such *Oils*; and for the very same Reason it is that *Water* is incompatible with them, and cannot insinuate itself into them, and more particularly when there is a powerful *Master* within, who rages, and resolves not to quit his hold, till he has first removed every thing belonging to him, and devoured all that can be converted into his own Form or Substance.

Sulphur has very great Virtues, which indeed for their Excellence ought to hold the First Rank; for from this *Ingredient* it is, that all the *Compositions* we have mentioned derive a great part of their Strength, and would infallibly be imperfect without it: Inasmuch as it is the particular Office of *Sulphur*, to conceive the *Fire* upon all Occasions, and having once conceived it to communicate it to the other *Ingredients* with which it is incorporated. In short, I believe there cannot be found any kind of Fat or Bituminous Substance, that can be comparable to this, as well for retaining and preserving a *Flame* when once conceived, as for protecting and defending it against all Enemies who by the Contrariety of their Qualities endeavour to destroy and suppress it; and this proceeds from a certain Sympathy between *it* and *Fire*, or from a natural Parity of Substance; or from some unaccountable occult Friendship mutually subsisting between them, and which renders them inseparable whenever they meet together.

Amongst the rare Qualities of *Camphire*, that of retaining and preserving an inextinguishable *Flame* is none of the least, and it may boast of being the only Oily, Bituminous, or Fat Substance to whom *Nature* hath granted so extraordinary a Property. But be this as it will, we by Experience

perience find, that without the help of any other *Ingredient* it burns in the midst of the Dampest Things, and maintains its Combustion with such Obstinacy, that it seems as if it would give Laws to them, even in their own proper Element. If you doubt this, light a piece of it and put it upon Ice, or if you will in Snow (taking care not to bury it close up, but to leave an Opening for the Air) and you will see that it will melt, both the one and the other, and support itself, notwithstanding their Frigidity, to its utter Consumption. Moreover, being pulverized, then lighted, and scattered over the Surface of Water, it produces an agreeable Appearance; for it seems as if the Water itself, upon which it floats because of its Lightness, was all inflamed. However you must understand that it does not conceive the *Fire* so readily from any particular Heat that is natural to it, but because it is of a very subtile Fat Substance. From whence happens that strange and admirable *Phænomenon*, that if you throw some *Camphire* into a Bason which has *Brandy* in it, and let it boil to its universal Evaporation, in some close Apartment, it will be rarified and converted into so fine a Vapour and such subtile *Effluvia*, that the Door being opened some time afterwards, and you immediately enter into the Place with a lighted Torch, all the Air in the Room will instantly take fire, and appear like a Flash of Lightning, without doing the least Damage to the Building, or without in the least hurting any of the Spectators. This arises from the extreme Subtility of it: For you must think that *Fire* will not burn, except when its Parts are very closely united: And this may be farther observed in the Paper of this Country, which being in a Blaze you may freely pass your Hand over it, without any danger of being burned. The same is it with *Brandy*, which emits so fine a Flame that an Handkerchief being dipped into it, it will be consumed from one End to the other of it, without hurting the least Thread of the Handkerchief.

All Sorts of *Pitch* and *Bitumen*, amongst which we may reckon the Raspings of *Yellow Amber*, (though it has naturally no great Affinity with them, as we shewed formerly from *Scaliger*) produce a strong Smoke, which retaining a great deal of *Fire*, and much Aerial Spirit in it, must consequently be very light, and tend upwards; and therefore breaking violently through the most closely united Parts of the Water, it serves as a Forerunner to the *Fire*, and clears the Way for it, to aspire in its natural Direction: For being collected in little Whirlwinds under the Water, it briskly blows up the superincumbent Liquid which opposes its Exursion, and causing at the same time a great number of large Bubbles upon the Surface of it, declares its Resolution of not submitting to an Element which is ordained by Nature to lye beneath it.

The *Sawduft* of Wood, *Filings* of Iron, and *Powder* of Glass, being heated by the other *Ingredients* which are more combustible than they, are blown up aloft by the Strength of the *Powder* and *Saltpeter*, where
 appearing

appearing like a Cloud or Shower of Sparks they yield an agreeable Prospect to the Eye, and immediately falling down again upon the Surface of the Water (hot as they are) you hear a Succession of small Noises which are by no means disagreeable: Now you must know that these Things are not used in *Compositions* purely to please the Eye or Ear; but they also greatly reinforce the *Fire* by keeping its Rays united; which is one Reason why it is able to subsist in any kind of Liquid. And indeed their real Office is to increase the *Fire*; for from its great Redundance, and Density it is, that it contemns the Attacks of its Enemy; and this we may reasonably affirm if so it be, that those Powers which are the most perfectly united are always the strongest. The Strength of these *Ingredients* is not a little added to, by their Confinement; because the Limits prescribed, being unequal to their violent Expansion, they rush with great Impetuosity through the *Vent* or Orifice of the *Ball*, or whatever else contains them; and thus *Scaliger* tells us, That Restraint adds to their Force.

I have now done with what I proposed to say concerning *Aquatic Compositions*; which may be of great Use to the *Pyroballist*, if he gives due Attention to it, and at the same time studiously considers the several Particulars we have here handled.

Give me leave to entertain you now with a *Story*, relating to the different Properties of *Fire* and *Water*, and the mutual Power they exercise over each other when they contend for the Sovereignty.

This *Story* is pretty common, and is related by *Philander* from *Suidas*, in the Preface to *Lib. VII.* of *Vitruvius*. *Ruffinus* also mentions it in *Ecclesiast. Histor. Lib. II. Cap. XXVI.* nearly in these Terms: *At the Time when the Chaldeans sacrificed to Fire as to a Divinity whom they revered above all other Celestial and Elementary Powers; boasting that their God alone was able to subdue all Things, and consequently (according to their way of arguing) it was but just and equitable, that those Honours should be paid to him which had been usually given to others: Adding that the Gods of other Nations, whether made of Brass, Silver or Stone, or any other Materials whatsoever, were unable to withstand him, and that he devoured all that came in his Way: It happened that the Priest of the God Canopus heard of this; who being a Man of Wit and Cunning, he undertook to undeceive them, and to demonstrate that there was still a Power, to whom their God would be obliged to yield: And in order to this, he caused a large Pitcher to be made full of Holes, which was well coated over with Wax, and painted of several Colours, and then filled with Water. This Pitcher being thus prepared, he fixed it upon the Shoulders of a great Statue (which he pretended to be the Statue of Menelaus) instead of the Head which he had taken off. In a little time after, the Chaldeans coming to be Witnesses of this decisive Contention between their Deity and the other, they let loose the Fire at him, who stood still expected his Adversary's Assault. At first (the Story says) the Fire animated by the Sight of so mighty a Colof-*

fus, laid hold on him with such Violence and Obstinacy, that every one present concluded he must remain Master of the Field, especially when they beheld the Immobility and Inaëctivity of his Antagonist. But Fate would have it otherwise, and soon made the Spectators of a different Opinion; for in a little while after this great Body had been thoroughly heated, and that the Fire had dissolved the Bonds which kept his Enemy imprisoned in the Scull of the Statue; he insensibly found himself seized with a cold Sweat, which trickling down from Head to Foot, soon slackened his Heat, and deprived him of all Hopes of the Victory he had promised himself. In short, the Combat did not hang long in Suspence; for the Holes of the Pitcher being by this time all opened, the Water gushed out furiously upon him, and overwhelmed him on all sides; so that in expiring he was obliged to acknowledge that he was overcome, and that Water ought to be preferred to him. The Chaldeans equally ashamed and afflicted to see their once-favorite God in this deplorable Condition, retired dissatisfied with the Combat, and from that Time forwards forsaking Fire, they sided with the Egyptians. This was the Event of the Canopian Priest's Stratagem.

C O R O L L A R Y III.

Of the Due and Proper Weight of each Water-Globe.

I AM now going to perform the Promise I made you, in my Description of the Firft Sort of *Water-Globes*. It is then very evident from the Experiments that have been made, and even from the Demonstrations of *Archimedes* (in *Lib. περι των ἐχθμένων, &c. seu de Inſidentibus Humido*, Prop. 3, 4 and 7.) where he speaks of Bodies immerſed in Water, *That Solids of equal ſpecific Gravity with Water, or any other Liquid, being immerſed into it, will remain ſuſpended in it, and will be ſupported by it, neither ſinking beneath nor riſing above the higheſt Surface of it. But Solids which are ſpecifically lighter than a Liquid, will upon being immerſed in it, aſcend above the higheſt Surface of it in a certain Proportion. In ſhort, Solids which are ſpecifically heavier than a Liquid, will ſink down to the Bottom, and loſe as much of their Weight whiſt in the Liquid as a Bulk of the Liquid equal to themſelves in Magnitude would weigh.* Therefore as all *Globes* deſigned for this Uſe are made of Wood, and notwithstanding they are filled with an *Aquatic Compoſition*, are lighter than Water, they muſt (according to *Archimedes*) riſe in ſome proportion above the higheſt Surface of it; and that in ſuch degree, that the Part of the *Globe* which is immerſed, preſſes upon the Surface beneath, with a Preſſure equal to that of a Bulk of Water as big as itſelf. Thus the immerſed Part of a *Water-Globe* bears ſuch Proportion to the Whole of it, as the Weight of the

the entire *Water-Globe* does to a Bulk of Water equal to itself in Magnitude, and so on by an inverse *Ratio*. Thus a Bulk of Water equal in Magnitude to the immerfed Part of the *Globe* is always equal in Weight to the Whole of it. As for Example; be there a *Water-Globe* whose Weight is 3 lb, and let $\frac{1}{4}$ of it be immerfed in Water, and $\frac{1}{4}$ rise above the highest Surface. I say, that in this Case the Weight of the whole *Water-Globe* is exceeded by that of a Bulk of Water equal to it in Magnitude in the same Proportion as the immerfed Parts of it are by the Whole, namely by $\frac{1}{4}$; and thus a Bulk of Water equal to the *Water-Globe* must weigh 4 lb. And by inverting the Proposition, if the Weight of a Bulk of Water be well known, and if a *Ball* be immerfed in it to $\frac{1}{4}$ of its Height, it will be evident that such a *Ball* or *Globe* will be $\frac{1}{4}$ lighter than such a Bulk of Water. That is, that a Body of Water containing 3 of the 4 Parts of the *Ball*, will weigh as much as the whole *Ball*. Now if these 3 Parts of Water equal to the 3 Parts of the *Water-Globe* are called 3 lb, we may safely conclude that the whole *Water-Globe* weighs 3 lb likewise. But we commonly contrive them in such a manner as not only to swim upon the Surface of the Water, but likewise to be just even with the very Top of it, and sometimes to be quite immerfed in it; that they may, by means of the *Fire* issuing from them, throw up the *Water*; and that the more the former is resisted by the latter, the more it may be enabled to oppose it, which is the great Point, and the only thing you are to endeavour at.

If now your *Water-Globes* are specifically lighter than Water, they will not be totally immerfed in it, but will ascend above the highest Surface in a certain Proportion; and as fast as the *Fire* consumes the *Compositions* in them, they will become still lighter, and must necessarily rise higher and higher till all is wasted. For this Reason it is necessary that your *Water-Globe* be of the same specific Gravity with Water, to the end that the *Vertex* of it may be exactly level with the Surface of the Water: Or it may be a little heavier if you will, that it may be totally immerfed; which will be best for the Reason above given (namely) because the successive Consumption of the *Composition* must naturally take away from the First Weight of the *Water-Globe*.

Now that you may know the specific Gravity of a *Water-Globe* with regard to Water, and consequently that Part or Portion of it, that would ascend above the highest Surface of the Water: And likewise that you may know, what Weight of Lead ought to be added to a *Water-Globe*, to make it *Equiponderant* with Water, or a little heavier: As also how to find the specific Gravity of Water with regard to your *Water-Globe*, without measuring or weighing either the *Water* or *Globe* by any ordinary *Mechanical* Contrivance; and that you may be perfectly well versed in whatever relates to this matter; I shall illustrate the Whole in the plainest Manner, by a Calculation of the First Sort of *Water-Globes* we described above.

We shall then suppose the *Axis* or Diameter of the said *Globe* to be divided into 9 equal Parts, each of which we will take to be an *Unciæ* of the *Rhynland* Foot; from whence we may easily come at its Solidity, and the Weight of a Wooden *Globe* made in that Form.

Let us range the *Analogy* as follows, (*viz.*) as 21 is to 11, so is the Cube of the Diameter of a *Globe* of 9 *Unciæ* (which is 729) to the Solidity of the *Globe* in Cubic *Unciæ* or Inches; according to the Demonstrations of *Christopher Clavius*, *Geomet. Prat. Lib. V. Fol. 253*. From this Operation you will have about 381 Cubic *Unciæ*, which would be the Contents of this *Globe* if it was Solid and Full; but as it is Hollow and Empty, and the Diameter of its Cavity is 7 *Unciæ*, we must find out the Contents of that Cavity in the same manner as if we supposed it to be Solid. Say then as 21 is to 11, so is the Cube of the Diameter of 7 *Unciæ* to the Capacity of the above-mentioned Cavity. Now the Cube of this Diameter being 343, the Capacity will be found to be 179 Cubic *Unciæ*, or thereabouts. This Capacity of the Hollow of the *Ball*, which is 179 *Unciæ*, being subtracted from 381 the whole Contents of the *Globe* (which we at first supposed to be Solid) you will have a Remainder of 202 Cubic *Unciæ*, which are the Contents of the whole Shell of this *Globe*, whose Thickness throughout is one *UnCIA*. To this must be added the Solidity of the Hemisphere upon the Tompion which stops up the Orifice of the *Globe*; which you may find out after this Manner.

Double the Plane of the Base of the Hemisphere, which shall be 3 *UnCIA* and $\frac{1}{2}$ square, or 42 Lines, and being doubled, you will have 7 *UnCIA* square or 84 Lines for the Convex Superficies. In short, multiply this by $\frac{1}{2}$ of the Diameter of the Base of the Hemisphere, and your Product will be 336 Lines for its Solidity, which are $\frac{1}{7}$ of an Inch and 48 Cubic Lines, which being added to the former Number will constitute a Body whose Solidity in Cubic Inches will be 202 *UnCIA* or Inches and $\frac{1}{7}$ and 48 Lines, or if you would have the whole reduced to Cubical Lines you will have 349392 of them.

You may again come at the Weight of this Body after this Manner. In the first Place suppose it to be made of Iron. Now according to the *Rule* laid down in Book I. Chap. VI. an Iron *Ball* whose Diameter is 4 *UnCIA* ought to weigh 8 lb; therefore as the Cube of the Diameter of a *Ball* of 8 lb is to its Weight, so is the Cube of the Diameter of a *Water-Globe* to its own Weight if it was made of Iron. The Operation being over you will have 49 lb, or thereabouts, for the Weight of the Shell if made of Iron: But as it is made of Wood, you must take the proportional Numbers of Iron and Wood from the *Table* Book I. Chap. IX, and say as 42: 3 so is the Weight of Iron last found to the real Weight of the Wooden Shell or hollow *Globe*; from whence you will have 3 lb, 8 *Ounces*, or thereabouts.

Let

Let the *Composition* which fills the Cavity of the *Globe* be here supposed to weigh 8 lb; 10 Ounces, 2 Deniers and 7 Grains; and let the Weight of the Iron *Petard* or *Cracker* be called 4 Ounces, and let the *Powder* in it be one Ounce. Now add the Weight of the Wooden *Shell*, to that of the *Composition* and *Cracker*, and you will have in all 10 lb, 11 Ounc. 7 Dr. 2 Den. and 12 Gr.

According to this same Method, you may find out the Weight of a Bulk of Water equal in bigness to your *Water-Globe*. We have said in Chap. XII. of Book I, from the Testimony of the *Ancients*, that a Vessel of a Roman Cubic Foot being filled with Water would weigh 80 lb Mensural, and but 66 lb 8 Ounces Ponderal. Farthermore, we have from the Observations of *Dogen* agreed, that the ancient Roman Foot was equal to what we call the *Rbynland Foot*; and therefore a Cubic *Rbynland Foot* of Water ought to contain as much in our Days as it did formerly: But as I have experienced that a Cubic Body of Water each of whose Sides is 6 *Unciæ* or half of the *Rbynland Foot* (the Water being taken out of the *Rhine* near *Leyden* in *Holland*) weighs about 8 lb 2 Ounces Ponderal of ours, each Pound 16 Ounces: It must follow, that as a Cubic Body whose Dimension is a Foot contains 8 of the aforementioned, it must weigh 65 lb of ours. And because on the other hand a Cubical Foot containing 1728 Cubic Inches weighs also 65 lb; 38 1/2 Cubic *Unciæ* or Inches, which are contained in a Bulk of Water equal to the *Water-Globe* we are now treating of, must weigh 14 lb, 5 Ounc. 2 Dr. 1 Den. and 8 Gr. as may be easily seen by any one who will give himself the trouble of proving it.

Well; let us now compare these two Weights to one another (namely) that of the *Water-Globe* filled with a proper *Composition*, which is 10 lb, 11 Ounc. 7 Dr. 2 Den. and 12 Gr. and that of a Bulk of Water equal in Magnitude to the aforesaid *Water-Globe*; which we have found to be 14 lb, 5 Ounc. 2 Dr. 1 Den. and 8 Grains; and by subtracting the Lesser of these from the Greater, we shall have a Remainder of 3 lb, 9 Ounc. 2 Dr. 1 Den. and 20 Gr. Now as this is exactly the 1/4 Part of the aforesaid Bulk of Water; we must conclude that the *Water-Globe* is 1/4 lighter than the Water; and consequently, that the 1/4 of the Water, of equal Magnitude with 1/4 of the *Water-Globe* will be as Heavy as the Whole of it.

Therefore if we would prepare a *Water-Globe*, so as to have it totally immersed in Water without sinking to the Bottom; and that the *Vertex* of the *Globe* should be exactly upon a Level with the Surface of the Water; we must add a Counterpoise (as we have called it) whose Weight is equal to the difference of the two Weights above-mentioned (*viz.*) the 1/4 Part of the Weight of the Bulk of Water, which is 3 lb, 9 Ounc. 2 Dr. 1 Den. and 20 Grains; that is, you must tie a piece of Lead to it of that Weight, or else make a Cavity round the lower Tom-pion, and pour as much melted Lead into it as will supply that Dif-

ference. In short, it would not be amiss if you added a Weight somewhat superior to the above-mentioned Difference, for several Reasons which I have already given, and which it were needless to repeat here.

Now in order to find out that Point upon the *Axis* of a *Water-Globe*, together with a certain Circle described round it upon the Convexity of the said *Globe*, through which if an Horizontal Plane pass, it would cut off a Fourth of the *Water-Globe*; or to shew how deep it would be immerfed in Water if it was a Fourth lighter than Water; I say in order to find out this, you may proceed as follows.

Since according to *Luc. Valerius*, who speaking of the Center of Gravity of Solids saith, *Lib. II. Prop. 33. Hemisphærii Centrum gravitatis sit punctum illud, in quo si Axis dividitur ut pars quæ ad verticem sit ad reliquum ut 5 ad 3. That the Center of Gravity of an Hemisphere is in that Point of the Axis through which if it was bisected, the upper Section of it would be to the lower as 5 is to 3.* Therefore you may divide the Semi-Diameter of a *Globe*, or the *Axis* of an Hemisphere, into 8 equal Parts; and as each of them is composed of $6\frac{1}{2}$ Lines, ' of the *Axis* of the Hemisphere, or $33\frac{1}{2}$ Lines, or 2 Inches, 9 Lines and $\frac{1}{2}$ measured upon the *Axis* from the *Vertex* of the Hemisphere towards the Base will give you its Center of Gravity; through which if a Plane be produced parallel to the Horizon, it will divide the Hemisphere into 2 *Æquiponderant* Parts; for it is properly called, *Centrum gravitatis uniuscujusque corporis*; or the *Center of Gravity of any Body whatsoever*, according to the Definition of *Guid. Ubaldus*, and other Mechanics. *Punctum intra extrave positum circa quod undique Partes æqualium momentorum consistunt; ita ut si per tale Centrum, ducatur planum figuram quomodocunque secans, semper in partes æquiponderantes ipsam dividat.* This Point, whether it be placed within or without, is That round which all the Parts of a Body are at rest, and situated in such a manner, that if a Plane be produced through that Center bisecting the Body in any direction whatsoever, it will be always divided into *æquiponderant* Parts. Therefore the upper Section of the Hemisphere is $\frac{1}{4}$ of the whole *Water-Globe*. And if from the Point last found on the *Axis* of any Hemisphere, you upon any Plane describe as from a Center a Circle whose *Radius* is equal to the upper Section of the *Axis*; and take the Circumference of such a Circle with a piece of Thread, and tying the two Ends of it together, you apply it to the Convexity of the *Globe*, it will sweep over that Portion of it as would be immerfed in Water, provided that such *Globe* be $\frac{1}{4}$ lighter than a Bulk of Water equal to it in bigness.

To tell you now how to find out the *Aliquot* Parts of an *Integer*, with regard to other Bodies of Infinite Variety as to Figure, besides such as are regular or approach nearly to a Regularity, or to teach how to separate them from the rest of the Body; is neither my Intention, nor my Business in this Place. The curious *Pyrobolist*, who would give himself

himself the trouble of learning it, may have recourse to *Villalpandus*, *Tom. III. Par. II.* or *Kepler's New Stereometry*, and the Works of many other *Geometricians* and *Mechanics*, who have written largely upon that Subject.

In short, the specific Gravity of Water, and the Weight of Bodies immerfed in it, may vary infinitely; and therefore we must retract what we said of *Water* in Book I. Chap. XII. The first thing you are to seek after in all Cases of this kind, is the Specific Gravity of the Water, without a Knowledge of which you may be liable to err. All that I have here said to you is but by way of Example, and to mark out a Path which will infallibly conduct you into the High Road, which leads to so many wonderful Operations.

But before I lay down my Pen, I must add to all this, a Method for † weighing all sorts of Bodies regular or irregular (for which it is chiefly designed) in Water; which will be as agreeable to our *Pyrotechnician* as it will be useful and necessary to him. I have taken it from *Merfennus*, and present it to you in his own Words, as you may find them in his *Phenom. Hydr. Prop. 46.*

What Archimedes means by Magnitude, is Body, tho' it be empty Space that is merely a Vacuum, and containing no corporeal Substance: Whatever has Extension, may be ranked under that Denomination, even by those who believe Space, (or who think there is a Medium) destitute of Resistance. If now you suppose such a void Space to descend in Water, the Water would rise as much as if a Solid Body of the same Bulk had sunk down into it: As for Example, a Vessel being filled with Air only, and pressed down into the Water, has the same Effect as if it had been filled with Water, or any other Liquid; so that if you suppose a Cubical Space which is perfectly destitute of Weight, to be forcibly immerfed and kept under Water, it would have the same Effect with respect to the Water as a Cube of Lead equal to it in Extension, allowing the Force requisite to keep it under is equal to the Gravity of the Lead.

But let us now proceed to consider Solid Magnitude or such as is Hard. Let there be for Example a Body lighter than Water, whose ‡ Gravity may be easily found by a previous Knowledge of the Gravity of the Water, or any other Liquid it may be immerfed into, as also the immerfed, or emerfed Parts of it. Let then the Part immerfed be to the Whole of it as 1 to 12, and the Gravity of the Water will be to that of the Body as 12 to 1: And if the immerfed Part of the Body is but Subquadruple or Subduple of the whole, a Body of Water of the same Bulk with the whole Body would be 4 times or twice its Weight.

† He, by this, properly means a Method of finding out the Specific Gravity of any thing with respect to Water, and so on inversely.

‡ He here all along means Specific Gravity.

You may by another way determine the Gravity of Bodies lighter than Water; (namely) by superadding a Substance that is heavier than Water, such as Lead whose Weight is known, and which by its Gravity immerses light Things; for it will be easy to conclude, that a Bulk of Water equal to them both, will be exactly the Difference of the Weight of those Bodies in Air and in Water; by the Weight of which you may readily come at the Gravity of the Body lighter than Water, by this Method of reasoning; (namely) That the Weight of a Body of Water equal in Bulk to the Lead being taken from the whole Mass of the Water which is equal to both the Lead and the other Substance, there will remain a Weight of Water equal in Bulk to the lightest Body.

For Example; Let there be given a Wooden Stick or Cylinder whose Weight in the Air is 12 Ounces, and be there superadded to it 11 Ounces of Lead, and throw them into Water. I say, that as this Lead weighs but 10 Ounces in the Water, a Body of Water equal to it in Bulk would weigh one Ounce exactly. Now let us suppose the Weight of the one and the other immersed Body to be 16 Ounces whilst in the Water, the Aggregate of whose Weight in the Air was 23 Ounces: The Difference between 16 and 23 being 7, it will give you to understand that a Mass of Water equal in Bulk to the Wooden Cylinder and Leaden Weight would weigh 7 Ounces; from which if you subtract a Body of Water equal in Bulk to the Lead only, there will remain 6 Ounces for a Bulk of Water equal to the Wooden Stick or Cylinder. The same thing will happen, if you immerse several Bodies together that are lighter than a Liquid, by means of a Superaddition of Lead, or any thing else that is heavier than such a Liquid.

But care must be taken that the Body immersed doth not contract, or imbibe any of the Liquid in its Pores, by which means it would be heavier than it was when weighed in Air: Tho' this Accident may be easily prevented by coating the Body well over with Wax, Pitch, or any thing of that Nature; for by subtracting a quantity of Water equal to the Wax, &c. the Remainder will infallibly give you the Gravity of the Porous Body. But you must first weigh the Quantity of Wax or Pitch used in coating the Porous Body, whether it be of Wood, Stone, &c. and furthermore know the Specific Gravity of the Wax or Pitch with regard to Water.

As for Example; suppose the Wax used in coating the Body weighs 22 Ounces in the Air, a Bulk of Water equal to it will infallibly weigh 21 Ounces; therefore must you subtract a Bulk of Water of 21 Ounces, if you would by the Weight of the Remainder of the Bulk equal to the Body, know the Specific Gravity of the Body itself, as we have already said.

If you would know any thing farther relating to this Matter, consult the same Author in the same Treatise, Prop. 43, 44, 45, 47, and others, which will satisfy you upon this Head. If these should not be sufficient, you may have recourse to Galileus, who speaks clearly on this Subject; and besides them, you have a little Italian Book published by

by *Nicolas Tartaglia*, intituled, *Ragionamenti de Nicolao Tartaglia: Sopra la sua travagliata Inventione.* With another intituled, *Regola generale da fulevar é misurar non solamente ogni offendata nave: ma una torre solida, di metallo trovata da Nicolao Tartaglia.*

C H A P. II.

Of Recreative Globes that leap and bound upon Horizontal Planes.

S O R T I.

TAKE an hollow Wooden *Globe*, perfectly Round, with its Orifice and Tompion, in the same Proportion and Form as we directed for the first Sort of *Water-Globes* in the foregoing Chapter; and fill it with an *Aquatic Composition*. Then be there 4 Iron *Petards* or *Crackers* (or more if you will) made in the Form you see in *Fig. 93* under the Fig. 93. Letters A, B, C, D: These you shall fill with the best *Corn Powder* you have, and stop them up with Wadds of Paper or Tow. Then boring Holes in your *Globe* of a proper Size to receive your *Petards*, you shall secure them with Nails to the Outside of your *Globe*; which done, you will have the Whole prepared. If you fire this upon a smooth even Spot, you will see it leap, and bound, as often as the *Petards* in it go off.

S O R T II.

Get a solid Wooden *Ball* made as Round as possible, and coat it well Fig. 94. over with Wax. Then cut long Slips of Paper of the Breadth of 2 or 3 Inches, and paste them to the Convexity of your *Globe*, so that it may be entirely covered with them, but not with one Layer only, but to the Thickness of one or two Lines: Or what will be more expeditious, Take of that Pulp or Paste of which Paper is made, and dissolve it in Glue Water, and with it coat over the whole *Globe*, and dry it by a very slow moderate *Fire*; and being perfectly dried, divide it into two Parts. In short, set it then before a *Fire* which is hot enough to melt the Wax, and you will have two hollow Paper Hemispheres (as you may readily conceive) with which you shall make a Leaping or Running *Ball*, after this Manner. Take three common *Rockets* filled and bored, as we directed for the First Sort of *Sky-Rockets*, excepting only the *Report* which is not here necessary. These *Rockets* shall be of such Length as not to exceed the interior Diameter of the Hemisphere. Fix then these *Rockets* in either of the Hemispheres, and dispose of them so as

D d d that

that they may have their Heads and Choaks alternately even with each other: And thus they must be ordered; that when the First is quite spent, the Second may immediately take Fire, and force the Hemisphere back again; and so on with the Third, when the *Fire* is communicated to that. Care however must be taken, that the *Fire* does not privately pass from the First *Rocket* to the Second or Third, before it is quite consumed: This Danger you may easily avoid, if you keep in Mind, what we have already said of two *Rockets* joined together, when we treated of those that run upon Ropes. Now in order to fire this *Globe* you shall make an Hole in your Paper Hemisphere over-against the Choak of the First *Rocket*. In short, all the necessary Precautions being taken in fixing your *Rockets*, you shall cover them with the other Hemisphere, which shall be firmly joined to the First with strong Pasted Paper; you must be careful in doing this, for fear lest in turning, running, and winding about, they should be torn from each other; whereby your Labour and Expence might become matter of Laughter to the Spectators, and yourself be put to Confusion instead of meeting with Applause. In a Word; supposing them to be well joined together, set fire to the Priming which corresponds with the First *Rocket*, and leaving it freely upon an even Horizontal Plane, you will see it run and fly about with such Swiftnes, and with so extraordinary a Motion, as will surprize the Beholders. In the same *Scenographical Figure*, the Letters A B C shew the *Rockets*, and how they must be fixed in the Hemisphere.

S O R T III.

This *Globe* is not very unlike the First Sort, excepting that to this you add a certain Number of *Crackers*, which are disposed as you may see in *Fig. 95*, where the *Crackers* are distinguished by the Letter A, and the *Vent* or Touch-hole by B.



C H A P. III.

Of Recreative Aerial Globes which are projected from a Mortar-Piece.

WHEN you would make any of these *Aerial Globes*, which are thrown up into the Air by *Mortars*, you shall first of all take care to have the *Calibre* of the *Mortar* you intend to use: And having found it, you shall divide it into 12 Parts, one of which you shall allow for the Windage of the *Globe*, and $\frac{11}{12}$ shall remain for the Diameter of the *Globe* you intend to make. You shall then divide this Diameter into 6 equal Parts; and the Height between A and C shall be equal to the Diameter of the *Globe*; the *Radius* of the Semi-Circle C I shall be $\frac{1}{2}$ or half of the Height or Breadth of the *Globe*. The Thickness of the Wood H I shall be $\frac{1}{12}$ of the above Diameter; but the Thickness of the Cover A K shall be $\frac{1}{4}$ of the Diameter of the *Globe*. The Diameter of the Cavity G H of this *Globe* shall be $\frac{1}{4}$ of its whole Diameter. The Height of the Priming-Chamber B F shall be $\frac{1}{2}$ and $\frac{1}{4}$ of the Diameter; but its Breadth $\frac{1}{2}$ only; that is, its Height shall be $1\frac{1}{2}$ of its Breadth. As for the Diameter of the Touch-Hole, it will be sufficient if it is $\frac{1}{4}$ or $\frac{1}{2}$ of that of the Chamber. Fig. 96.

This is all I can say of the Proportions of this Sort of *Balls*, as to their Wooden Construction: But as for the Manner of filling them, the following Directions will fully instruct you. The Figure of this *Globe*, and those which follow it, may be plainly understood by *Fig. 96*.

Observe here, that the Proportions of these *Globes* are only to be understood of those which are projected from great *Mortars* (namely) such as can carry a *Stone Ball* of 30, 40, 60, or 100 lb, or more if you can get any such: But for the Lesser, which carry but 6, 10, 15, or 20 lb of *Stone*, these *Globes* may be made of Pasted Paper, and rowled in fashion of a Cylinder, excepting only the Bottom which shall be of Wood, as well as their Priming-Chambers and Vent-holes.

S O R T I.

Take hollow Canes or common Reeds, and cut them into Lengths to fit the Cavity of the *Globe*, and fill them with a *slow Composition* made 3 Parts of *Meal Powder*, 2 of *Coal*, and one of *Sulphur*, moistened with a little *Oil of Petrol*; excepting the lower Ends of them which rest upon the Bottom of the *Globe*, which shall have *Meal Powder* only, moistened in like manner with *Oil of Petrol*, or sprinkled over with *Brandy*, and then

then dried, to make them take *Fire* the better. You shall moreover cover the Bottom of the *Globe* with *Meal Powder* mix'd with an equal quantity of that in *Corns*. These Reeds being filled after this manner, you shall set as many of them upright in the Cavity of the *Globe* as it is capable of containing. Then cover it well at Top, and wrap it well round, with a Cloth dipped in Glue, or any tenacious Substance. The Priming shall be of the same *Composition* with the Reeds, or one of the two following. The First; made of 8 Parts of *Powder*, 4 of *Saltpeter*, 2 of *Sulphur*, and one of *Coal*. The Second; 4 Parts of *Powder*, and 2 of *Coal*. Meal, mix, and incorporate these *Ingredients* together as well as possible. To conclude, you shall stick round the Orifice or upon it (with a little *Pyrotechnic* Glue, which we shall speak of in the following Book) some *Quick-Match* (which must be prepared as we directed in Book II. Chap. XXIX.) with some untwisted Tow of the same sort. Fig. 96 shews you the whole of this; for the Letter L points out the Reeds contained in the *Globe*. The rest needs no Explanation.

Fig. 96.

S O R T S II and III.

Fig. 97,
and 98.

These two Sorts of *Recreative Globes*, which you see represented under *Figures* 97 and 98, are perfectly contrived like the First Sort, with only this Difference between them, that the First of these is filled with *Running Rockets*; and the Last with *Paper Crackers* and *Stars*, and *Pyrotechnic Sparks* interspersed with *Meal Powder*, which are put promiscuously over the *Crackers*. It is needless then to dwell any longer upon these, since you may gather whatever relates to them, from what I have said above, as also from the Representations of them; which are so plain, that it is impossible for any Body to be mistaken that does but consider them a little.

S O R T IV.

Fig. 99.

This *Globe*, which we rank in the Fourth Place, and which we have represented in *Fig. 99*, is not so difficult in its Construction, but that it may be easily comprehended by the *Figure* itself. First of all, the Great *Globe* which contains a Lesser in it, is the very same with those above-described; for it is charged with *Running Rockets* as well as that of the Second Sort: But however with this Difference, that this is lined but with a single Range of *Rockets*, as may be seen in the Letter A; whereas the Cavity of the other is quite filled up with them. In the midst of these *Rockets*, you fix a *Globe* in a Cylindrical Form with a flat Bottom as B, and a Chamber and Touch-hole at D. The Capacity of this Inner *Globe* is filled with *Iron Crackers* as C, and covered with a flat Covering as E. You shall fill the Priming-Chambers with the same *Com-*
position

position as we have ordered for the above *Globes*. As for the *Fuzes* they shall be of good *Meal Powder*.

S O R T V.

As for the Construction of this Fifth Sort of *Recreative Globes*; it differs in nothing from the Fourth above described, except that it is larger and more capacious, and contains two others one within another. The Biggest of all is distinguished by the Letter A, which is charged with Tubes D; (the Construction of which we have so often given) whose Orifices are all turned downwards, upon the Bottom of the *Globe*, which is spread over with *Corn* and *Meal Powder* mixed together. The Second and Middlemost, distinguished by B, is in like manner charged with one Row or Round of *Running Rockets* E. In short, the Third and Smallest *Ball* C is charged with other smaller *Rockets* as may be seen in F; in the Middle of which is a *Light Ball* G. As for any thing farther relating to it, you are to proceed in the same Manner as was ordered with regard to the aforementioned Sorts; see the Representation of this *Fig. 100*, which will illustrate it, if our Explanation is any way defective.

S O R T VI.

First get a *Wooden Globe*, in the Middle of which let there be made a *Mortar*, with a little Chamber for *Powder*; round which shall be formed a *Berm* or *Ledge*, for the conveniently ranging of certain Paper Tubes or Cases: In this *Berm* you must hollow out a little Groove or Channel, which must be filled with *Meal Powder*, for conveying the *Fire* all round. This done, you shall put a *Recreative Globe* into the *Mortar*, filled with *Running Rockets*, *Paper* or *Iron Crackers*, *Reeds*, or in short, with *Stars* and *Sparks* which we have so amply described elsewhere. Upon the abovesaid Channel then, you shall place your Cases or Paper Tubes, exactly after the Manner we ordered in the foregoing Chapter for the Sixth Sort of *Water-Globes*, which shall be filled with *Running Rockets*, and covered round with strong pasted Paper or Glued Cloth. Cast your Eye upon *Fig. 101*, where the Letter A points out the *Wooden Globe* without any Addition to it. The Letter A also shews its *Mortar*. E the Hollow in the *Berm*. D the Touch-hole. C the Priming-Chamber, and B is the Chamber of the *Mortar*. But in the other *Figure* distinguished by B, the Letter F shews you the Order in which your Paper Cases ought to be placed upon the hollowed *Berm* or *Ledge*. The rest may be readily comprehended by whosoever rightly considers this *Fig. 101*.

S O R T VII.

Fig. 102. You shall order a Wooden *Globe* to be made whose Height is double of its Breadth; such as you see in *Fig. 102*, where its Height from A to B, is double of its Breadth from C to D. So much for its outward Form. Hollow out one half of it (I mean the upper Part) after the same Manner as has been done with regard to the preceding *Recreative Globes*; which Cavity shall be filled with *Running Rockets* or *Crackers*, or some other of those Things we have mentioned above. Then clap a Cover over it. The Lower Part of this *Globe* shall have a Priming-Chamber at E, whose Height and Breadth shall be $\frac{1}{2}$ of the Diameter of the whole *Globe*; and the Touch-hole shall be $\frac{1}{4}$ or $\frac{1}{2}$ of it. This done, you shall pierce all the Lower Part of the *Globe* with Cavities which shall not be so deep as to interfere with the Touch-hole in the Middle; but between the Inner Extremities of them and that, there shall be the Thickness of half an Inch of Solid Wood: Which however shall be afterwards bored with a red-hot Iron, so as to have a Communication with the Touch-hole. You may see how this is to be done by the Letters G and F. These Cavities shall be of sufficient Capacity to receive *Iron Crackers* or *Running Rockets*. Now to repeat to you, how they ought to be fixed; what ought to be observed to make them depart after they are lighted; or what must be done or not done to procure the desired Effect from them; this is what I have so often touched upon, that a farther Repetition might be troublesome. Let us then proceed to the following Sort.

S O R T VIII.

The Structure of this *Globe* is not so considerable on the score of its Contrivance, as it is admired by the Spectators for its fine and agreeable Effects in the Air; and I may safely say, there are but few *Pyrobalists* who can represent in the Air, in a dark cloudy Night, Letters or Cyphers in *Fire*, or whole Names, or even several Sentences all in *Flame*. Here then in the Construction of this *Globe* (which I myself invented, and have often put in Practice) I intend to shew you one of this Nature, which will have such Effects as cannot but be admired: In the ordering of which you must proceed as follows. In the first Place get a Wooden *Globe* of the same Form, and of the same Height, Breadth and Thickness, with that of the First of this Sort of *Globes*, or of the subsequent of them, no matter which. Now the Priming-Chamber A, in *Fig. 103*, shall have its Breadth and Height of $\frac{1}{4}$ of the Diameter of the whole *Globe*. Besides this Chamber you shall have another to receive *Corn Powder*, whose Height C D shall be equal to its Breadth D E, which shall be also $\frac{1}{4}$ of the Diameter of the whole *Globe*; but the
Fuze

Fuze or Vent-hole B shall have its Breadth one fourth of the Powder-Chamber, or Priming-Chamber above mentioned. You shall have also another *Globe* in a Cylindrical Form, the Bottom of which shall be rounded on the Outside, as may be observed in the same *Figure* by the Letter F. The Cover of it, G, shall be let a little into the Inner Surface of the Cover of the Great *Globe*, in order to keep it firm; and this Lesser *Globe* shall be placed perpendicularly over the Chamber which is filled with *Corn Powder*. You shall then fill the Cavity of this little *Globe* with *Running Rockets, Stars and Sparks*, as may be seen by the *Profil*. To the rounded Bottom of this *Globe*, shall be tightly fitted a Wooden Ring (the *Profil* of which you have in H;) the Substance of which shall be bored through with Holes, as you may see in I; or if you will, it may be fluted all round, as may be seen in K; or finally, you shall plant small Iron Nails all round the Bottom of the *Globe*, in such manner that their Heads may be all even, and form a perfect Circle, whose Diameter exactly corresponds with the Inner Diameter of the *Globe*, and its Circumference with the Circumference of the same. See it represented in *Fig. L*. After having prepared your *Globe* after this manner, take two long thin Slips of Whalebone (which the *Germans* call *Walfschbein*) which naturally permitting itself to be bent without any danger of breaking, and inclining to a voluntary Recurvature, it is very proper for the Use we shall here apply it to. You shall then take two Slips of it, which though rowled up in a Spiral Direction, have Strength and Spring enough to recover their first Rectitude, upon their being released from their Constraint. Having two such pieces of Whalebone join them together, disposing of them so that their Convexities may be Inward, and their Concavities Outward, as may be plainly seen by M. Of these two curved Slips, you shall make one strait Piece as N by tying them down at the Ends and in the Middle: These Slips thus joined together, though bent and rowled up after any manner whatsoever, will by their own natural Spring and Energy recover their Rectitude, when left at liberty.

Take two Pieces thus prepared, and lay them Parallel to each other (consider here the *Figure O* composed of those Artificial Characters which express *Vive le Roy*) and to the Extremities of them tie two shorter Pieces at right Angles with them; so as to constitute the right-angled Parallelogram P T S Q. These four Pieces being thus bound together, you shall form the Letters or Cyphers within them, which shall be made of Lattin or Iron Wyre, or (what will be much better) of pieces of Whalebone; but your Letters, &c. must be of such Size as not to exceed the Height of the Cavity HR, and if they are somewhat shorter it will be so much the better, as we have ordered it in our Example. Again; your Letters shall be at the Distance of a Palm from each other, or a Foot at most: In a Word, their Distances shall be according to the Capacity of the *Globe* you intend to put

put them into. Your Letters being thus fixed in your Frame (or Parallelogram) take loose Pyrotechnic or Quick Tow (prepared as we directed in Chap XXIX. of Book II.) and wrap them neatly round with it from one end to the other; then steep them in Brandy, in which you shall have previously dissolved a little Gum *Arabic* or Gum *Dragant*, and as you dry them falt them over with *Meal Powder*. You must however take care that the pieces of Whalebone which form your Frame, are no ways incommoded or intangled by your Tow; for fear when your Letters burn out, their Flame should be confounded in one another, and become indistinct in the Air. If now you would have your Letters descend perpendicular to the Horizon, you shall fasten two small Weights to your Frame at S and Q only; but if you would have your Frame fall down parallel to the Plane of the Horizon, there shall be two other Weights at P and T; that is, there shall be a Weight at each Angle of your Parallelogram or Frame. Finally, the Whole being thus ordered, bend it round to go into the Inner Circumference of your great *Globe*; and let it rest perpendicularly upon H in the foresaid *Globe*, and then fill up the empty Spaces between the Letters with *Meal Powder*. This done, cover it up, and I assure you nothing can be more delightful to the Sight, and that you will receive an unpeakable Pleasure from the Effects of this *Globe*; provided that in the Construction of it you observe every thing that is here directed.

You may by a Contrivance of this Kind not only represent Letters and Cyphers in *Fire*; but also the Arms of Princes and great Lords, together with Human Figures, and Animals, which will move to and fro in the Air, to the great Satisfaction of the Beholders. But you must know, that to succeed in such fine and difficult Attempts, it requires a Person to be possessed of a pretty good share of Sense, and sound Judgment, joined to a perfect Knowledge in *Pyrotechnics*, and a fine Taste of every thing relating to it: And where these Qualifications are wanting, I would advise no Body to engage themselves in such a Work; for neither *Æsculapius* nor all his Successors of the Faculty, can find one Remedy throughout the whole Extent of their *Science* to repair the least Mishap that might befall you in this Case.

C O R O L L A R Y I.

Of Shining or Light-Balls, such as are commonly used at Bonfires, which the Germans call Lichtkugel.

THERE are two Sorts of *Light-Balls* (namely) the *Recreative* and *Serious*; of the Last of which we shall speak in its proper Place; and shall now only cursorily touch upon the *Recreative Sort*.

Take

Fig. 89.

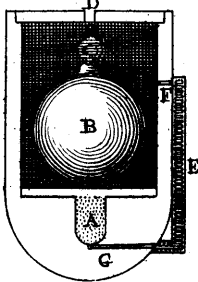

Fig. 90.

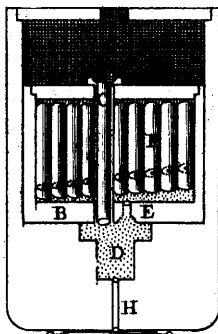

Fig. 91.

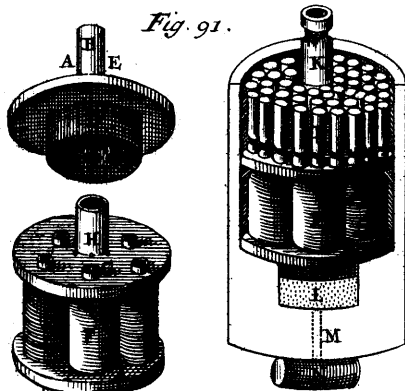

Fig. 92.

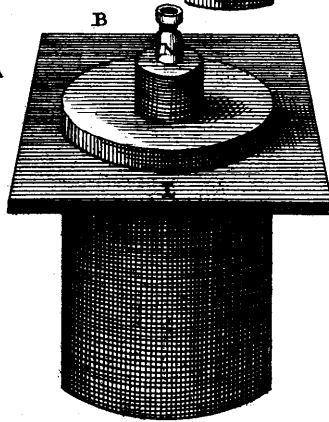
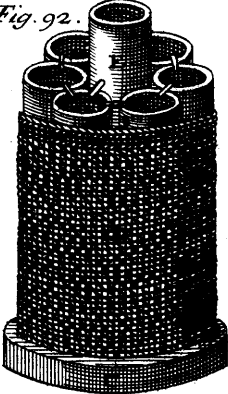

Fig. 93.

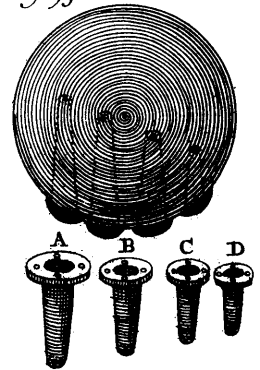

Fig. 94.

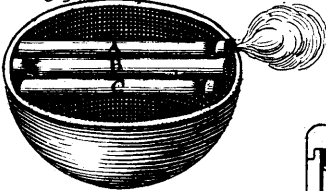

Fig. 96.

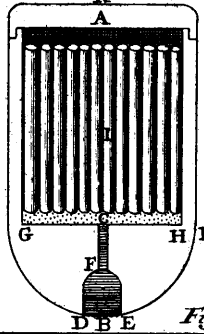

Fig. 97.

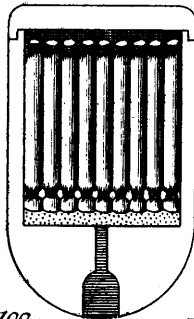

Fig. 98.

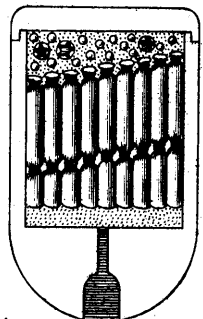

Fig. 95.

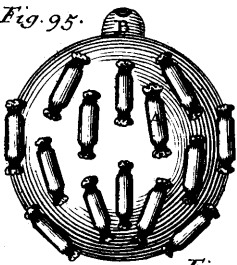

Fig. 99.

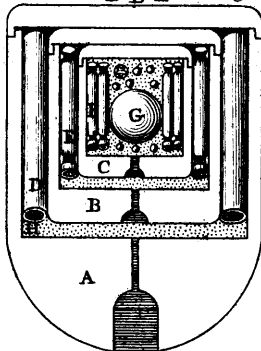
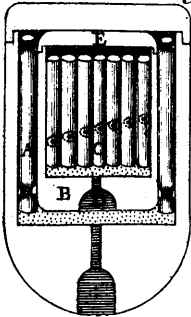

Fig. 100.

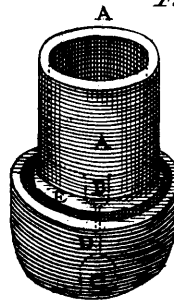
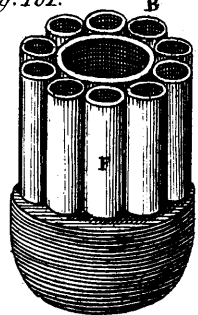

Fig. 101.



K

Take of *Crude Antimony* 2 lb, of *Saltpeter* 4 lb, of *Sulphur* 6 lb, of *Colophone* 4 lb, and of *Coal* 4 lb.

Or else; take of *Antimony* lb ss, of *Saltpeter* j lb; of *Sulphur* lb ss, of *Colophone* j lb, of *Coal* j lb, and of *Black Pitch* lb ss.

You shall put either of these *Compositions* (after having been well mealed) into a Brass Boiler, or into any glazed Earthen Pot, and melt them over a Fire. Then throw as much Hemp or Flax into them as may be sufficient to absorb them quite up: And whilst cooling, you shall make them up in *Balls* of such Sizes as you want. Then wrapping them well up, and coating them with *Pyrotechnic* or *Quick Tow*; you may put them into *Rockets* or *Recreative Globes*, whether *Aquatic* or *Aerial*.

C O R O L L A R Y II.

Of Pyrotechnic Stars and Sparks, called by the Germans Stern-veuer and Veuerputzen.

PYROTECHNIC Stars differ thus much from the Sparks, that they are a great deal larger, and not so soon consumed; but subsist in the Air, and shine out with a longer Duration, and with a Splendor which because of its extreme Brightness, may in some degree be compared with the real Stars which adorn the Firmament. They are to be prepared after the following Manner.

Take of *Saltpeter* lb ss, of *Sulphur* ʒ ij, of Powder of *Yellow Amber* ʒ j, of *Crude Antimony* ʒ j, of *Meal Powder* ʒ ij.

Or else; take of *Sulphur* ʒ ij ss, of *Saltpeter* ʒ iiiij, of Powder finely mealed ʒ iiiij, of *Olibanum* or *Frankincense* in Drops of *Mastic*, of *Crysal*, of *Mercury Sublimate*, of each ʒ iij, of *White Amber* ʒ j, of *Campfire* ʒ j, and of *Antimony* and *Orpiment* of each ʒ ss.

All these *Ingredients* being well beaten and passed through a Searce, they shall be sprinkled over with a little Glue Water, or Water of Gum *Arabic* or *Dragant*: Then made into little Balls of the Bigness of a Bean or small Nut; and being dried by the Sun or Fire, they shall be laid up in some convenient Place, to be used in the *Artificial Fireworks*, which we have here so amply treated of. When you put them into *Rockets* or *Recreative Globes* they must be wrapped up in *Quick Tow*. *Pyrobolists* sometimes instead of these Balls take certain Quantities of a melted Stuff (which we shall speak of hereafter when we teach you the Preparation of *Fire Rain*) which they wrap up in *Quick Tow* for several Uses in *Fireworks*.

But if these do not please you because of their blackish Cast, and if you would rather choose to have them Yellowish or inclining to White;

F f f

Take

Take \bar{z} iiij of *Gum Dragant*, or of *Gum Arabic*, beaten, mealed and passed through a Searce; of *Campfire* dissolved in *Brandy* \bar{z} ij, of *Saltpeter* lb j fs, of *Sulphur* lb fs, of coarse *Powder of Glafs* \bar{z} iiij, of *White Amber* \bar{z} j fs, of *Orpiment* \bar{z} ij: Incorporate all these *Ingredients* together, and make *Balls* of them as before. I learned this of *Claud Midorge*.

The Method of making *Sparks* is as follows: Take of *Saltpeter* \bar{z} j, of the same melted \bar{z} fs, of *Meal Powder* \bar{z} fs, of *Campfire* \bar{z} ij. After having mealed these *Ingredients* (such as want it) apart, put them all together in an Earthen Pot, and pour upon them Water of *Gum Dragant*, or *Brandy* that has had *Gum Dragant* or *Gum Arabic* dissolved in it, that the Whole may have the Consistence of a pretty Dense Liquid. This done, take an Ounce of Lint, or the Down of Linnen, which has been previously boiled in *Brandy*, *Vinegar*, or *Saltpeter*, then dried and spread out, and throwing it into this *Composition*, mix and stir it about, till it has absorbed it all. This done, rowl it up in Pills about as big as a great Pea, which you shall set to dry after having salted them with *Meal Powder*. Use these according to our Directions.

We have, farthermore, a Way of preparing certain *Odoriferous Pills*, which are used in little *Pyrotechnical Machines* and Contrivances, which are fired in Rooms and Closets. These are commonly composed of *Storax Calamita*, of *Benjamin*, of *Gum Juniper*, of each \bar{z} ij; of *Olibanum*, of *Mastic*, of *Frankincense*, of *White Amber*, of *Yellow Amber*, and of *Campfire*, each \bar{z} j; of *Saltpeter* \bar{z} iiij, of *Lime-Tree Coal* \bar{z} iiij. These *Ingredients* are to be well beaten, pulverized and incorporated together; then moistened with *Rose Water*, in which has been previously dissolved some *Gum Arabic* or *Dragant*, that the Whole may be made up in Pills, which must be dried in the Sun or before a Fire.

C O R O L L A R Y III.

Of the most certain Method for Projecting Recreative Globes from a Mortar: Of the Quantity of Powder requisite for that Purpose: And of the Chambers to receive it.

YOU must consider that all these *Recreative Globes* are usually thrown up into the Air in a Vertical Line, or against the Perpendicular of the Horizon; wherefore it is necessary that you should have a thorough Knowledge of the due Quantity of *Powder* requisite to dislodge your *Globe*, and to project it into the Air to any determinate Height you would have it. We may come at this by two Ways. The First is thus:
Weigh

Weigh your *Globe* with a Balance or Steelyard, and for every Pound that it weighs allow $\frac{1}{4}$ of an Ounce of *Gun-powder*. As for Example; if your *Recreative Globe* weighs 40 lb, you must, to dislodge it, allow 40 — $\frac{1}{4}$ of an Ounce, or 10 Ounces of *Powder*: And this will be full enough for the purpose; for these *Globes* being made of Wood only, they could not bear the violent Shock of a larger Quantity; add to which, that the *Powder* confined in *Warlike Machines* exerts itself more to throw up a Body in a Right Line, than to project it in any Oblique Direction; because it is proportionably more oppressed by the superincumbent Weight, and has its Liberty thereby more restrained. This I shall endeavour to demonstrate more amply elsewhere. If you should be in a Place where no such thing as a Balance or Steelyard is to be got; take the Diameter of your *Globe* with a pair of common Compasses, or with a pair of the crooked Sort, and apply it to that Side of the *Calibre Scale* calculated for Stone Bullets, and divide the Number to which your Compasses extend into two Parts, and you will have the Number of *Loths* or *half Ounces* of *Powder* requisite to dislodge your *Globe*.

Now suppose you do know the due Portion of *Powder* requisite to project your *Globe*, yet methinks this is not enough; for you ought to know also, how and in what Form this *Powder* ought to be put into the *Mortar*. We have two Ways of coming at this. The First of which: Be there made a certain Body of soft yielding Wood, in the Form of a truncated Cone reversed, (which the *Germans* call *Setz-Kamer*) equal in Height and Breadth to the Chamber of the *Mortar*, in which shall be hollowed out a Chamber for receiving the *Powder*. This shall be pierced with a fine Borer, or a red-hot Iron Needle from the bottom of the Wood to the Center of the bottom of the Chamber in it; but not in a perpendicular Direction, but diagonally or slanting as from c to d in *Fig. A* under 104. The place where this Touch-hole begins shall be *Fig. 104.* marked, so that when you fill the Chamber, it may be turned to correspond with the Vent-hole of the *Mortar*. When therefore you would load your *Mortar* with a *Recreative Globe*, cover the Bottom of the Chamber with a little *Meal* and *Corn Powder* mixed together, and upon that put your Wooden Chamber, in which shall be the Quantity of *Powder* requisite to project your *Globe*. In short, your *Globe* shall have its Orifice turned down upon the *Powder*, and shall be wrapped round with Hemp or Flax, Hay or Straw, no matter what, so that it be not any thing that will retard its Flight, and hinder its Projection. Consult *Figure 104*, which will give you a perfect Idea of all this.

Observe here, that your Wooden Chamber ought to be of a Capacity sufficient to hold all the Requisite of *Powder*, and on the contrary, it shall not be so big as not to be entirely filled by it.

If by chance the Chamber of your *Mortar* is broader than needful, or if its Height is not well proportioned to its Breadth; or in short, if the

the Requisite of *Powder* is so little as not to fill up the Chamber; (which may frequently happen, inasmuch as *Recreative Globes* are much lighter than *Grenado's* or *Bombs*, &c. for which *Mortars* were chiefly designed; which have accordingly spacious Chambers to receive the Requisite of *Powder* necessary to project those heavy Bodies, and notwithstanding you may make according to our first Method a Chamber that is just sufficient to contain the Requisite of *Powder*; yet as in such a Chamber the *Powder* is not closely united, but is rather extended too much, it will not be so vigorous, nor act with such Force upon the superincumbent Weight, as if it was confined to some Chamber whose Cavity is proportioned to the Effect required; for the Reasons here-under given) and therefore it will be necessary to have some Wooden Cylinder equal in Height and Breadth to the Chamber of the *Mortar*; in the Middle of which shall be bored a Cavity, whose Height is equal to that of the Chamber of the *Mortar* to hold the Quantity of *Powder* necessary to throw up the *Recreative Globe*. Now this may be done as follows.

First, by a Scale divided into equal Parts, measure the Height of the *Powder* contained in the Chamber of the *Mortar* that is requisite to project your *Globe*; and then by the same Scale measure the whole Height and Breadth of the Chamber. Then find out a mean Proportional between the Height of the *Powder* in the Chamber and the Height of the whole Chamber itself. This mean Proportional being found, you shall look out for a Fourth Proportional; by saying, As the mean Proportional found, is to the Height of the *Powder* in the Chamber, so is the Breadth of the Chamber to a Fourth Number. Having performed this after the common Way you will have a Fourth Proportional, which will be the Diameter of the future Chamber, capable of containing your due Requisite of *Powder*, which Diameter you shall measure by the above Scale. This will be readily apprehended by the following Example.

Fig. 104. Let then the Chamber of your *Mortar* be a, d , in Fig. 104 under the Letter B, and let the Height of it be $a c$ or $b d$; let the Height of the *Powder* in the Chamber be $c e$: Thus $d e$ will be the Cylinder that contains a Quantity of *Powder* requisite to project your *Recreative Globe*. As this *Powder* is not sufficient to fill up the whole Chamber, there must of necessity be a vacant Space between it and the *Globe*, which rests upon the Orifice of the Chamber. Now since, so large a Vacancy may be a great Hindrance to the Ejaculation of the *Globe*, and since the *Powder* is but a very little Quantity when compared with the Capacity of the Chamber; therefore must this Cylinder or Chamber which now contains it, be transformed and altered, into another equally capacious to it, and whose Height shall be at the same time equal to the whole Height of the Chamber of the *Mortar*. This is to be done after the following Manner.

Find

Find out the Height of the *Powder* between e and c, which we will here suppose to be 20 Parts or Divisions of your Scale; and the Height between c and a, or that of the whole Chamber, which we will suppose to be 45 of the aforementioned Parts; the mean Proportional between these two Numbers (*viz.* 20 and 45) being about 30; say, As 30, the Proportional Number immediately found, is to e c, the Height of the *Powder* in the Chamber which is 20 Parts of your Scale; so is c d or a b, the Breadth of the Chamber of the *Mortar*, which is 24 of the same Parts, to the Diameter or Breadth of the Chamber you would prepare. This performed, you will have 16, which will be the Diameter of the Orifice sought. Hollow out then of your solid Wooden Cylinder l o, equal in Height to the Chamber of the *Mortar* a d, the Concave Cylinder g k, the Diameter of whose Orifice g h is 16 of the same Parts with the 45 which constitute the Height of it l n, or g i: Thus will you have a Chamber of a Size requisite for your Purpose.

Observe here, that in this Case, and in such a Chamber, it is not at all necessary to press down the *Powder*, and that it will be better to have the Interstices of it free and open, that the Air may be diffused throughout it, and that the *Fire* may have free Passage to inflame it all at once, and instantaneously.

If this kind of Chamber does not please you, get a Wooden Former whose Diameter is equal to the Cavity of the last mentioned Chamber, and either paste or rowl as much strong Paper upon it, as may give it such a Thickness and Length as exactly to fit the Chamber of the *Mortar*. You have the *Figure* of this in D. It is my Opinion, that there can be no better Reason given, why *Powder* when confined in a long narrow Chamber, should have a more violent Effect, than when an equal Quantity of it is lodged in a broad shallow one; than that the *Powder* is much more united in the Former than in the Latter, where it is more extended; from whence it happens, that the Density of the *Fire* issuing from the close confined *Powder* is more considerable, the Exhalations and Expansion much more abundant; the Union of the Parts of the *Fire* much more perfect; and consequently the Flash must be every way more powerful, as I said above.

In a Word; I believe the true Reason why the *Ancients* invented *Chambers* for their *Mortars* and *Cannon*, was because those Engines were chiefly designed for projecting *Stone-Bullets*: But as in those Times they also used *Mortars* for throwing out certain *Pyrotechnical Globes* (as is still practised, and to which we have lately added *Bombs*, &c.) which requiring but a little *Powder* in Proportion, to what was necessary to project those ponderous Bodies of Stone; if their small Requisite had been lodged in a spacious Cavity it could have performed no notable Effect, for want of being collected in a close Body: To remedy this Inconveniency, the antient *Pyrobolists* contrived *Chambers* in their *Mortars* which are as it were little *Magazines* for keeping the *Powder* close together,

ther, that by the Proximity of its Corns, its expulſive Force might be perfectly united, and acting impetuoſly upon the Projectile, oblige it to depart as faſt as its Weight will permit. I have however often obſerved, that the Chambers in old *Mortars* and *Guns* were much larger than ours, the Reaſon of which was, becauſe their *Powder* was much weaker than ours, which was owing to the ſmall Quantity of *Saltpeter* in it; wherefore it was neceſſary that their Chambers ſhould be proportionably large. This, the Modern *Pyroballiſts* have altered; for in our Days, that *Mars* ſeems to have been more inſolent and outrageous than ever, thoſe who have had the ordering of the *Artillery* have greatly leſened the Chambers, becauſe our *Powder* is much more ſtrong, than what was formerly uſed; and therefore our Chambers muſt be proportionable to the Virtues and Qualities of the *Powder* they are to contain. If what I have been here ſaying, does not ſeem ſufficient to you, to clear up what I have here offered concerning the weaker or ſtronger Effects of *Gunpowder*, in proportion to the Capacity of the Chambers where ſuch Effects are produced, I ſhall ſtill farther endeavour to illuſtrate it by an Example of *Pneumatical Engines* or *Wind-Guns*; for if into any two of them of equal Capacity you inject an equal Quantity of Air, it is certain that the Air ſo condensed being ſet at liberty, would ruſh with much more Noiſe and Impetuoſneſs through a narrow Tube, than through a broad one, and attack any Obſtacle in its Way, and impel it with a Power, much more conſiderable than the other, and all from the different Size of the Tubes or Barrels; (if we are here to underſtand *Wind-Guns*;) and it is certain that in unequal Capacities the greateſt or leaſt Quantity of Air would help or hinder the Violence of the Air iſſuing from two unequal *Engines* or *Guns*; for that Quantity of Air which was ſufficient to ſwell or fill up a ſmall Tube, would not be enough to fill up a larger Tube; but would diſperſe on all Sides, and diffuſe itſelf throughout the whole Capacity of it, and could not be ſo much condensed in its Excuſion through a Space where it has room to expand itſelf. Thus is it with *Hydraulic Machines*, which throw up their Water the higher, the narrower their Pipes are; which alſo moves with a greater Horizontal Velocity, than that which runs through large Pipes or Channels; ſuppoſing ſuch Water to run in Channels or Pipes equally inclined to the Plane of the Horizon, and to be of equal Quantity, &c. The Cauſe of theſe different Effects may be accounted for, by what we ſaid above, (namely) That it is more compacted in narrow Channels, in which being hurried along by any Force impreſſed, or only left to the liberty of running its inclined Courſe, it flows along with wonderful Rapidity. It is quite different in ſpacious Channels, where the Water has room to ſpread abroad. Apply this now to *Gunpowder* in the Chambers of Warlike Engines, where being converted into a Fiery Spirit, which when it finds itſelf oppreſſed and pent up in a narrow compaſs, exerts its whole Strength to diſengage itſelf from all

manner of Restraint, and having forced a Passage to the Air, it violently explodes and disperses that Element, which instantly closing together again, produces that shocking Clap which is heard upon the discharge of all Pieces of Ordnance.

C O R O L L A R Y I V.

Of Recreative Petards or Crackers.

WE have often mentioned *Petards* or *Crackers* in the preceding Chapters; but have said nothing yet of their Construction. You must know then, that there are two Sorts of *Petards*, which the *Germans* call *die Schlage*: One Sort of them being used in *Recreative Fireworks*; (which only I shall here treat of) and the other is applied to Serious and Warlike Uses, concerning which we shall speak hereafter. The Form then of the Recreative Sort may be very much varied. Now of an infinite Number of them, those which you see in *Figures 105, 106, 107 and 108* in A and B, are such as I choose to give you the Representation of. Some of these are made of Paper; as you may see by B, in *Fig. 105 and 108*; which are formed in Moulds particularly contrived for them, one of which we have already represented and described in Book III. Chap. III.

Others are made of Iron and Copper Plates, and some of Lead as may be seen in *Fig. 106, 107 and 108*, distinguished by the Letter A.

Those which are made of Paper after the manner that you see in *Fig. 105 and 106*, have their Upper Parts (distinguished by A) filled with *Corn Powder*; and their Priming-Chambers must rest upon one and the same Plane, that they may not all go off at once, but by Intervals one after another. The Chamber of the First towards the Right Hand, shall be Subquadruple of the Last towards the Left, as well in those of Paper as those made of any thing else. As for the Proportion of the Chambers between the First and the Last, they gradually increase in going upwards, and consequently the *Composition* in them must increase in Proportion: This may be readily conceived by the Oblique Lines b and c, upon the one and the other *Scenographical Figure*, which are Parallel to two other Oblique Lines distinguished by d, and which terminate all their Heights in such manner, that they are all of an equal Capacity, with regard to that Part of them which is filled with *Corn Powder*. The Inequality of their Chambers shall be then contrived as we just now ordered, and shall be filled with a *slow Composition*, which we have already given you, or else with the following *Composition*.

Take of *Meal Powder* 3 Parts, and of *Coal* one Part, beat them and incorporate them well together. Carry this *Composition* into some damp Place,

Place, that it may contract a little Moisture, and by that means be the more easily consolidated; or else you may sprinkle it over with a little Oil of Petrol or Linseed.

In the *Iron Crackers* you must have little Iron Partitions to separate the *Composition* from the *Corn Powder*: These Partitions must be pierced in the Middle, that the *Fire* may have Conveyance to the *Corn Powder*. In *Paper Crackers* what we call the Priming-Chambers and Orifices, must be made just after the same Manner as we choak *Rockets*, with this Difference only, that they must be choaked closer in these than in those, according to the Size and Quality of your *Crackers*.

Fig. 107. As for those which you see in Fig. 107, they are filled only with *Corn Powder*, and stopped well up at Top with Paper or Tow, and have small Vent-holes at Bottom where they receive the *Fire*.

Fig. 108. In short, those *Crackers* which you see in A Fig. 108 are closed up both at Top and Bottom with thin Iron Plates, which must be well soldered to the Tube, and pierced. As to the Method of charging them, you make an Hole in one Side of them to put in *Corn Powder*.

That which you see in B, must be ordered after the following Manner: After having choaked it close up at Bottom with strong Pack-thread or Cord, fill it up with *Powder*, and choak it close at Top. This done, bore an Hole through the Side of it, into which you shall put a little Iron or Copper Fuze filled with *Meal Powder*. Thus you will have your *Crackers* ready for Use, and properly adjusted.

Sometimes instead of *Crackers* we use hollow Leaden Bullets (which are mere *Grenado's*) which are filled with *Corn Powder*; we have applied several of this Sort to our *Water-Globes* in this Book, Chap. I. Besides these there are others made in Form of a *Cube*, some of a *Tetrahedron*, others of a *Prism*, and in many other Shapes *Regular* and *Irregular*.



PART II. *of this* BOOK.

Which TREATS of

FIRE-GLOBES; or BALLS

PREPARED FOR

MILITARY USES.

THE Number of *Artificial Balls* prepared for the several *Military Purposes* is almost infinite, so that it is impossible to give an Account of them all: For which Reason I shall only touch upon some of the best and principal of them; but more particularly upon those which are used in our Days; which I shall in this *second Part* of this *Book*, delineate and explain to our *Pyrobolist* with all the Perspicuity and Accuracy I am able. I shall allot a Chapter to each Sort of them, in Consideration that they differ pretty much from each other in Effect; and are distinguished accordingly by particular Appellations.

C H A P. I.

Of Hand-Grenado's.

S O R T I.

AS to the Form of *Hand-Grenado's*, it is perfectly Spherical, as is also the Cavity in the Middle of them; and they are called *Hand-Grenado's* from being grasped, and thrown by Hand, to annoy the Enemy. If we would stick to the *Latin* Denomination of them, we should call them *Palmary Grenado's*, because their Hemispheres commonly fill

H h h

up

up the Palm of the Hand; for they are usually of the Size of an Iron Bullet of 4, 5, 6 or 8^{lb}. They sometimes weigh 1 ^{lb} or 1 ¹/₂ ^{lb}, and sometimes 2 or 3 ^{lb}. They are called *Grenado's* from the Resemblance they bear to the † *Punic Fruit* which we call *Pomegranates*; for as the Rind of these incloses a vast Number of Grains, from whence they derive their Name of *Granates*; so our *Military Grenado's* are filled with innumerable Grains or Corns of *Gun-powder*, which taking Fire, burst them into a thousand Splinters, which fly against, and grievously oppress the Enemy; therefore *Leonard Frontzberger* in his *Artillery* calls them *springende* and *schlagende Kugelen*; which is as much as to say, *leaping* or *bounding*, or rather *striking Balls*, if we may so express ourselves. Now this last Appellation of these *Balls* may be very properly applied to all the greater *Grenado's*; which doubtless borrowed their Name from the smaller Sort, which have a greater Natural Resemblance to the *Punic Fruit* above-mentioned than the Larger have: Add to which, that it is certain the Small ones were used before Men (industrious to each other's Ruin) invented the Great ones. And indeed we do not find the least Footsteps of the great *Grenado's* amongst the ancient *Pyrobolists*; but their Writings make ample and particular mention of the smaller as what they were perfectly well acquainted with, tho' at the same time it must be confessed that they called them by other Names, and treated of them in a different Manner from us. *Boxhornius* relates something which agrees pretty well with our Sentiments concerning *Hand-Grenado's* in his History of the *Siege of Breda* in the Year 1617.

Grenado's (says he) which we have so often mentioned, derive their Appellation from their Resemblance to *Pomegranates*; and are hollow Iron or Brass Globes, the Diameter of whose Cavity is 3 Unciæ or Inches, and whose Thickness of Metal is 3 Lines. They are filled with *Gun-powder*, and sometimes with particular Compositions; in their Vents they have *Fuzes* which are slow indeed in Combustion, but very susceptible of Fire, and calculated to burn for some time, to avoid the danger of their bursting in the Hands of those who throw them. The same Author says in another Place, That they forbore to throw those *Balls* which derive their Name from the *Punic Apple*; because as they required a good deal of Powder, and the Besieged falling short in that Article, they could not afford to supply them with it.

But it were to no purpose to dwell any longer on the Etymology of these *Balls*, since every Body knows what is meant by them. Let us then proceed to the Order observed in the Preparation of them; which indeed is somewhat needless after what we have quoted from *Boxhornius*: But however I must beg Leave to add three or four Words which shall favour more of *Pyrotechnics* than of *History*.

† This is the same with *African* and *Carthaginian*.

With regard then to the Matter of which they are formed, *Hand-Grenado's* may be said to be of three Sorts; the First and moſt common of which are made of Iron; the Second of Braſs mixed and allayed with other Metals; and the Third of Glaſs. If you would have them of Iron, they muſt be the moſt brittle and the leaſt wrought that they can poſſibly be. If you would have them of Braſs or Copper, you muſt mix 6 lb of Copper with 2 lb of Tin and half a lb of Marcaſite; or elſe it ſhall be one lb of Tin, with 3 lb of Lattin. Thoſe which are made of Iron, ſhall have their Metal throughout, of the Thickneſs of $\frac{1}{4}$ of their Diameters. Thoſe which are made of Braſs ſhall be $\frac{1}{5}$. And thoſe which are made of Glaſs, ſhall be $\frac{1}{6}$ of their Diameters in Thickneſs, as may be ſeen in the *Fig.* 109 under the Letters A, B and C.

Fig. 109.

The Diameter of the Vent ſhall be $\frac{2}{3}$ of the Diameter of the *Grenado*; and the little Hole ſhall be $\frac{1}{18}$ of the ſame Diameter: It is through this that the Body of the *Grenado* is filled with *Corn Powder*.

The Fuze which you ſee in the Letter D, ſhall have its Diameter from Outside to Outside $\frac{2}{3}$ of the Diameter of the *Grenado*, or it ſhall be a little leſs that it may eaſily ſlip down into the Vent. The Length of this Fuze ſhall be $\frac{2}{3}$ of the ſame Diameter; and the Hollow of it ſhall be $\frac{1}{2}$, and the Top of it ſhall be a concave Hemisphere, as may be ſeen by the aboveſaid *Figure*. This Concavity muſt be filled with *Powder* finely mealed, which muſt be moiſtened with a little Gum or Glue Water, that it may ſtick together the cloſer. As for the Body of the Fuze itſelf, it ſhall be filled with one of the *Compoſitions* here-under given; then capped with Tow, and ſome of that *Pyrotechnic Cement* which the *Germans* call *Kit*; which is made of 4 Parts of *Ship Pitch*, 2 Parts of *Colophone*, one Part of *Turpentine*, and one Part of *Wax*; theſe are all put into a glazed Earthen Pot, melted over a ſlow Fire, and mixed and incorporated well together.

Compoſitions for the Fuzes of Grenado's.

I.

Of *Powder* one lb; of *Saltpeter* one lb; of *Sulphur* one lb.

II.

Of *Powder* 3 lb; of *Saltpeter* 2 lb; of *Sulphur* one lb.

III.

Of *Powder* 4 lb; of *Saltpeter* 3 lb; of *Sulphur* 2 lb.

IV.

Of *Powder* 4 lb; of *Saltpeter* 3 lb; of *Sulphur* one lb.

S O R T II.

The *Hand-Grenado* I am now going to describe, differs in no respect from the former, excepting in its Fuze, which is otherwise contrived, and which together with some other minute Circumstances, is all that constitutes this, a *Grenado* of a different Sort from the foregoing. We Fig. 110. have given you a Representation of this in *Fig. 110*; in the Preparation of which you are to take Notice of the following Rules. First, get a Wooden Fuze made (though it may be of some Metal if you will) whose Length is equal to the Diameter of the *Grenado*, and its Breadth equal to the Diameter of the Vent; but it shall be thicker and larger at Top by $\frac{1}{2}$ of a Diameter, where it is to be hollowed out in a Concave Hemisphere. The lower Part of it, which is to go down into the *Grenado*, shall be bored with several Holes which shall be filled with *Meal Powder*. This done; fix it in the *Grenado* in such manner that the lower End of it may rest upon the Bottom of the Shell, and secure it as we said before; then fill the *Grenado* with good *Corn Powder*, which you are to do by a little Hole on one Side of it, which shall afterwards be stopped up with a little Wooden Pin or Spile which must be very forcibly driven in. The Head of the Fuze shall be crowned or adorned with Sprigs of fresh and green *Box*, which shall be tied with Packthread, to keep them fast whilst they are handled.

When you would put these *Grenado's* in Practice, take a little End of Match, of such Size as to be able to slip readily down the Hollow of the Fuze, and tye a little Leaden Bullet to the lower Extremity of it. Then light your Match, and as soon as it has acquired a good Coal, put it into the Fuze with its Bullet downwards, and throw the *Grenado* where you think fit; and be assured, that as soon as it strikes against the Ground, the Leaden Bullet and its Match will fall down in the Fuze, and by lighting the *Meal Powder* in the Side Holes of it, will fire the *Grenado* and split it into a thousand Pieces. The Sprigs of *Box* are not designed so much for Ornament as Use in this case; for they serve to keep the Vent of the *Grenado* upwards, or in a Vertical Position whilst it is in the Air, so that falling upon its Bottom, it may shake down the Leaden Bullet, and consequently the Match with it: This Contrivance may likewise be of Use to other Bodies which are to fall down upon Horizontal Planes.

This *Grenado* is most frequently armed with Leaden Bullets; that is, the Outside of it is covered with them, that it may do the greater Execution. In order to do this, you must first coat the *Grenado* with melted Wax which must have a certain Quantity of *Colophone* mixed with it; into which you may sink as many Musquet Balls as you please whilst it is cooling: Then wrap the Whole up in a Cloth, and bind it well round with Packthread.

S O R T III.

In *Figure III*, I give you the Representation of a *Hand-Grenado* Fig. III. (though it may be of a larger Size if you will) which may be privately hid at the Entrance of any Avenue, or in any narrow Passage, through which you expect the Enemy to come. This *Grenado* has two Holes Diametrically opposite to each other; through which passes a Wooden or Metal Fuze, pierced all round with Holes, primed and salted over with *Meal Powder*; through this Fuze you draw a piece of common Match lighted at one End: The *Vertex* of this *Grenado* has a Third Hole (or Vent) where you fill the Cavity of it with *Corn Powder*, which being afterwards firmly stopped up with a Tompion, your *Grenado* will be prepared. I believe I need not teach you the Use of this, which you may easily gather from the *Figure* itself, and which upon occasion Necessity may suggest to you.

C O R O L L A R Y.

How to Throw or Deliver Hand-Grenado's.

AFTER our Definition and Description of these *Grenado's*, we need not tell you that they are grasped and thrown by Hand, at such times as the Enemy is within the reach of your Strength: Nor need we tell you that they are both Offensive and Defensive *Arms*, which those who know nothing of the matter, may learn from such as have been present at *Sieges*: We shall only add, that *Hand-Grenado's* are very much used after the happy Success of a *Mine*, which has made a Breach in some Rampart, thrown down a Wall, or blown up a Bastion; it is then that they are used to clear the Way in mounting the Breach: It is upon such occasions, that you see the most generous and brave of each Side, armed with Fire and Flame, valiantly maintaining the Cause of their Prince, the Interest of their Country, their Liberties and their Lives. Or when the Besiegers have got to the Foot of a Rampart, and are obstinately bent upon insulting it, and insensibly scale it; (being covered by the Rampart itself from the Defences of the Flanks :) It is then that the Besieged are to shower down *Grenado's* upon the Enemy, and of which the Besiegers are to make the best returns they can, to procure themselves a free and safe Passage; as was not long since seen at the *Siege* of *Hulst*, which was taken by the *Hollanders*. But it is impossible to enumerate the several particular Uses of *Hand-Grenado's* in the Occurrences of War, and especially when both Armies are so near as to be almost at Handy-cuffs with each other. It is sometimes necessary to

throw them at great distances; but here I mean one after another: I shall hereafter shew how to throw several together, which being a Work unequal to the bare Strength of a Soldier, the Masters of this *Art* have invented little convenient *Machines* for that Purpose; the best Sort of
 Fig. 112. which I represent in *Fig. 112*, after having made some necessary Additions to it. With this *Machine* you may not only throw *Hand-Grenado's*, but several other Sorts of *Military Fire-Works*, such as *Light Balls*, *Bombs*, *Fire-pots*, *Fire-boops*, *Garlands*, and *Crowns*, and several other such like things, which we shall speak of in their proper Places.

There is nothing difficult in the Construction of this *Machine*, and it may be easily comprehended by the *Figure* itself: I shall only add, that so much the longer that Arm of it is, which is made in the Form of a Ladle (into which the *Grenado* is to be put) than the other Arm to which the String is fastened, so much the more powerful will it be. You must here understand their Length to be measured from the Center of the Iron Spindle, upon which they turn, to one and the other Extremity of the Arms; and in this they imitate a Balance.

Boxhornius also mentions, in the above-quoted Place, a certain new invented *Machine*, made like one of our *Mortars*, and well fortified with Iron Rings, with which they shot *Hand-Grenado's* into *Breda* during the *Siege*. And it is not long since we saw at the *Siege of Hulst*, and since then at *Murpshey*, which is a pretty strong Place, a like *Machine* constructed by a bold *English* Soldier, who presented it to *Frederic Henry* Prince of *Orange*, of immortal Memory; of whom this *Englishman* demanded 100 *Dutch Florins* for the Trouble he should take, and the Danger he should incur in throwing his *Grenado's*: In short, he obtained his Demand, and began to play his *Machine*; but to say the Truth, he did it so awkwardly, and with so little Judgment, that the greatest part of his *Grenado's* either did not reach the Place they were designed for, or broke in the Air; which was attributed to the Defect and Imperfection of the *Engine*, together with the Ignorance of the Engineer who wanted Skill to govern it.

We shall, in the Second Part of our Work, give you a Treatise upon *Mortars*, in which we shall take occasion to speak of a little *Machine* of our Contrivance, more perfect and artificial than this, for projecting *Hand-Grenado's*, or greater Shells if you will, and to throw them just where you please: But that for which it is as useful as admirable, is its being able to throw several at once, as for instance 7 at a time, or one after another according as the Exigence of Affairs requires; to which I for the present refer the Reader who is so curious as to want the Construction of it.

But upon the whole I cannot help admiring at the rigorous Sentence, which the first Inventors of our *Art* passed upon the *Warlike Machines* of the Ancients, as if guilty of some notorious Crime, for which they resolved entirely to banish them from the *Modern Arts of War*; and

and to carry their Contempt of them so far, as to burn them ignominiously in their Kitchens, that there might not remain any Footsteps of them; conceiving perhaps that their Successors, convinced of their Innocence, might one time or other recal them from Banishment, if they were not utterly destroyed. And indeed if the Writings of so many great Men their Contemporaries, who had seen their wonderful Effects, did not bear witness of the great Services they did, whilst they were in their greatest Splendor and most venerable Majesty, we should never have known any thing relating to their Construction. An ungrateful Return sure they meet with, for their great and mighty Performances! Must Contempt be the Reward of their illustrious Executions, by means of which *Rome* became Mistress of the *World*, and triumphed over Nations and Kings till then Invincible? No: it would be in vain to dwell upon this Subject; they have suffered great Injustice, and still continue to suffer it, and are now not even admitted into the most inferior Class of the Servants of *Mars* and *Bellona*, but are totally rejected, and condemned to an inglorious Inactivity; and are so far sunk in Point of Reputation, that whosoever offers any thing in Favour of them, is sneered at by a Pack of ignorant Fellows, who openly scoff at the great Exploits they formerly did, and look upon them as Romances and old Women's Tales.

But to what purpose do I waste my Time in defending the Cause of those injured Inventions? *Lipfus*, the greatest and best Judge that ever was of the Ancient and Modern *Arts of War*, has sufficiently pleaded in their Behalf; to whom we are infinitely obliged for the Trouble he has been at in tracing out the Uses and Services of them: It is from him that we have collected so rich a Store of what concerns the wonderful *Machines* of the Ancients, and which we shall dwell upon when we come to compare them with ours. My sole Design at present is to evince, that all the Sorts of *Grenado's*, and the other *Pyroballical* Inventions in present Use (which might be projected by the *Slings*, and † *Fundibali* of the Ancients but not by the *Balistræ*) may be flung very conveniently to very great Distances.

First then; I beg of you to listen to what I am going to say of the surprizing Strength and admirable Effects of *Slings*, which indeed are so very great, that when I first read and considered them, I was perfectly transported. *Ovid* speaks somewhere of them to this Purpose.

*Non secus exarfit, quam cum Balearica Plumbum
Funda jacit, volat illud & incandescit eundo
Et quos non habuit, sub nubibus invenit Ignes.*

In *English* thus:

It burns, as when from *Balearic* Thong,
The pond'rous Lead with nervous Force is flung;

† These were a kind of *Slings*.

Which flies and whistles through the airy Height ;
And glows with raging Heat contracted in its Flight.

By this it appears, that in his Time they used the *Sling* for *Leaden Balls*, which were perhaps filled with Combustible Matter, since he says that they took Fire in their Flight, and acquired a Flame in the Air by their violent Motion. *Lucan* says as much :

*Inde faces, & saxa volant, spatiaque solutæ
Aëris, & calido liquefactæ pondere glandes.*

In *English* thus :

There Fiery Darts, and rocky Fragments fly ;
And melting Bullets whistle thro' the Sky.

All these *Fire-Brands* or *Darts*, *Flying Stones*, *Melted Bullets*, which he here speaks of, were the true *Fire-Works* of his Time, which they shot at the Enemy with *Slings*, or some such Contrivance.

I shall pass over several other Authors, the Testimony of whom is collected by * *Lipfius* to prove what he says of *Slings*. But I cannot omit what † *Seneca* says in his *Natural Questions*. *Motion* (says he) *rarifies the Air, and that extreme Rarefaction generates Heat : Thus a Bullet projected from a Sling is melted by the Attrition of the Air as much as it would have been by Fire.* Does not this appear very strange ? Surely if we had not the Testimony of so many great Men, we should at once look upon these as Romantic Fables. *Joseph Quercetan* seems to think them Fabulous in his Book of the *Carbine*, where he disputes against †† *Aristotle* ; who says, *That the Darts and Javelins were so heated by the Friction or Attrition of the Air, that they were hot enough to melt Lead.* This, *Quercetan* flatly denies ; inasmuch as Experience teaches the contrary, by shewing that *Musquet Balls*, &c. which are projected by *Fire*, and that with greater Violence (these are his Words) than any Arrow or Dart can be shot, are not heated to that degree. Let us now examine into the Weights, Sizes, and Qualities of these Bodies ; and at the same time we shall see how far the ancient *Slings* could throw them ; which is partly the End and Aim of this Essay.

Diodorus Siculus speaking of the Inhabitants of the ††† *Balearic Islands*, says, †† *That they were the most dextrous People in the World at slinging great Stones.* The same Author says elsewhere of these Islanders, *That they had acquired such a Perfection in the Exercise of the Sling, that they could cast great Stones with such Strength and Violence that they seemed*

* *Lipfius* Lib. V. Dial. seu Coll. XX. de Mil. Rom.

† *Sen.* Cap. LVI.

†† *Arist.* de Cælo, Cap. VII.

††† These are now called *Majorca* and *Minorca*.

†† *Diod. Sic.* Lib. VI.

rather to be shot from † Catapultæ, so great and violent was the Blow they gave! which broke Shield, Helmet, and every other kind of Armour, though never so well tempered. An uncertain Author in *Suidas*, says of the same People, That they slung Stones of the Weight of a Mina: By which he means an *Attic Mina*, which weighed 100 *Drams*, as we have said elsewhere; but *Cæsar* calls them *Libral* or *Pound Slings*. So much for the Weight of the Stones they used to sling; which, according to what we have said above, agrees pretty well with the Weight of our *Hand-Grenado's*. We are told also that besides Stones, They used to sling *Leaden Balls* at their Enemies, without the Assistance of any Engines but their *Fundæ* or *Slings*; which we cannot compare with any thing more properly than with our *Grenado's*. An uncertain Author in *Suidas* says, That the ‡ *Cadurci* were reckoned the best *Slingers*; and that they could cast Stones and *Leaden Balls* to that Nicety as never to miss their Aim. They had farthermore a way of slinging Pots full of *Fire*, into the Places they Besieged when they were near enough to do it, or had got Possession of the *Outworks*: But I cannot avoid thinking that these *Fire Pots* were heavier than our *Grenado's*. *Appianus* in his *Libic.* says, That the *Romans* had raised high *Terrasses* opposite to those *Towers*; from whence they threw a great Number of lighted *Torches* and *Fire-Brands*, together with *Vessels* full of *Sulphur* and *Pitch*. And *Dion.* in *Lib. XX.* speaking of the Time when the *Romans* besieged the *Capitol*, which their *Slaves* had possessed themselves of, says, That there were Those who slung *Vessels* full of *Bitumen* and *boiling Pitch* from the *Houses* in the *Neighbourhood* of the *Capitol*. However this was, we must believe it since they say it: But all these things were only so many *Forethoughts* of our *Hand-Grenado's*. You will find still something farther to this Purpose in || *Julius Cæsar's Commentaries*, where he says, That a great *Wind* rising, the *Gauls* began to sling upon our *Cabbins* and *Huts* (which were only thatched with *Straw* after the Fashion of the Country) hot *Balls* which were made of a fusible *Earth*; and at the same time showered a vast number of very hot *Javelins* upon us. But *Lipsius* is of Opinion, that this ought to be rendered *Earthen Vessels* filled with melted or boiling *Matter*. *Orosius* speaking also on the same Subject, says, That they took red-hot *Pots* or *Earthen Heads*, and threw them at their *Enemies*.

It was thus that the *Romans* and the most Warlike Nations their Contemporaries used the *Sling*, as well in attacking their Enemies as defending themselves. If you would know in what great Esteem they were held within the Memory of our Fathers amongst our *Northern Neighbours*, even since the Invention of *Gun-powder*; consult *Olaus* the great Archbishop of *Upsal*, who was one of the most learned Writers

† These were Warlike Engines to shoot Darts or Stones.

‡ The ancient Inhabitants of *Guienne* in *France* were formerly so called,

|| *Jul. Cæs. Com. VII.*

that ever lived in the North; and who speaks in these Terms: † *The Aquilonians, or Northern People, when they design to besiege some Town, or attack a Camp, have certain flexible Chains, or a kind of Links and Joints of Iron made fast to Sticks or Staves, which they prefer to all other Arms, particularly when the Country is stony. But in such Places where they can get no Stones nor Pebbles (which seldom happens in those Parts) they sling pieces of red-hot Iron, which they put into the Purses of their Slings with Pincers. You always see them with a certain Vessel in their Hands made like a Roman Barrel, full of Crufts and Pieces of Iron, which being heated red-hot, and slung at the Enemy, they make so strange and dangerous a Wound, that whoever has the Misfortune of being struck by them, must hope for no Help from any Physician or Surgeon. And the reason why this Iron wounds so dangerously and irrecoverably (observe this) is because of its Weight and the Adustion it causes in the Part. The Remembrance of an Event like this, is still fresh in the Person of Christiern the IIId King of Denmark, who lost a mighty Army in the Year 1521, at the City and Camp of Arofen, by means of such contrived Arms. For here they did the same with burning Darts, which being taken with Iron Pincers from the Fire, and put upon Ballistæ (for they promiscuously used the ancient and modern Machines together) they were shot from them, and wounded the more incurably, according to their degree of Heat, which made it sometimes impossible to draw them out with the Hand: But what was the most disastrous and dreadful; these burning Darts and Pieces of red-hot Iron, falling upon their Gun-powder it was instantly fired, and went off with a deafning Clap, and burned and stifled all the circumadjacent Soldiers; and what still added to their Misfortune, was the IncurSIONS and Outrage of the Mountaineers, (a Savage Brutal Race bred in Subterraneous Caverns and Mines) who overwhelmed them with Darts, Stones, and Pieces of hot Iron, which they showered upon them with their Slings. I saw (says he) 250 Italian Miles from thence, several that were brought by Sea to Stockholm; a most terrible Sight to behold! some were without Noses, others had lost their Eyes, these their Arms, and those their Legs: In short, their Wounds being incurable, the Germans, Scots and Danes in particular, died in the utmost Misery.*

Let us now have done with the Size, Weight, and Quality of the Bodies that were usually thrown from the Slings of the Ancients: And indeed I believe I have said enough on this Subject for you to draw some Conjecture of the Distance they could carry, as well as of their Certitude of hitting what they aimed at. But ‡ *Vegetius* speaks very plainly of this Matter, when he says, *That the Archers and Slingers set up a small Fagot, or Bundle of Straw for a Mark, from which they retired to the distance of 600 Foot, and hardly ever missed it with the Arrows they shot, or the Stones they slung.* We read also in Holy Writ, || *That among the In-*

† Olaus Lib. VII. Cap. VII. ‡ Veget. Lib. II. Cap. XXIII. || Judges Chap. XX. ver. 16. *habitants*

habitants of Gibeah there were seven hundred chosen Men left-handed, every one of whom could sling Stones at an hair's-breadth and not miss. The Roman Surveyors had moreover a certain Measure which they assigned to Fields and Grounds, which answered to the Cast of a Sling; from whence they called a Farm with all the Tillage belonging to it, *Fundus*, (which the *French* at this Day call *Fonds*;) whose Breadth and Length was a Sling Cast. Those who know any thing of this Measure, affirm that it was 600 Foot. We find something to this Purpose in *Quintilian in Jocul.* in these Words.

*Fundum Varro vocat, quem possim mittere Fundâ
Ni tamen exciderit qua cava funda patet.*

But to what Purpose should we dwell any longer upon the Power and Properties of the *Sling*? Let us now try whether or no, we can, according to the Rules of Modern *Architecture*, conveniently sling *Grenado's* from our Lines of Approach into the Enemy's Intrenchments. First then it is a general Rule amongst our *Military Architects* or *Engineers*, to begin their Lines of Approach at the distance of 60 Rods from the Place Besieged; if the Situation of it will not permit to break Ground nearer without Danger. This Distance is equal to the Level Range of Bodies projected from *Slings*; for it is thus that you must understand what *Vegetius* says above of the Exercise of the *Roman Soldiers*; which also is taken Notice of by several other Writers: And it is likewise with us the Practice of our *Musqueteers*, to exercise themselves at a Mark set up at about the Height of a Man, from whence they retire 200 or 300 Paces, to acquire a Certainty in their Aim, and to familiarize the thing to them, when they come to engage with the Enemy Face to Face. But as this Method of aiming is quite different from the Projection of our *Hand-Grenado's*, the former being Parallel to the Horizon, and the latter in a Curve, in which the Body falls into the Enemy's Works, we must find some other way of doing it.

Now it is very evident from the Observations on the Shots of our great Guns, &c. that the Line of Shot which the *French* call, *de niveau*, and the *Italians*, *de ponto in bianco*, and We, *point blank*, is the Tenth Part or thereabouts of the utmost Random, at an Elevation of 45 Deg.

It is farther certain, that all Projectiles observe one constant Proportion: Therefore if any one takes his Aim, to sling an *Hand-Grenado* after having swung it a few times round his Head; and endeavours to throw it at the distance of 6000 Foot, or 600 Rods, which is ten times as far as the Spot where you begin your Lines of Approach is from the Place besieged (provided always that it does not exceed 60 *Toises* or Rods, or 600 Foot) I do not in the least doubt that it would fall within the Enemy's Walls; for all Those who use the *Sling*, or throw any thing with

with the Arm only, are naturally led to project it in an Angle of 45 Deg. or thereabouts. But suppose they were to be thrown to the distance of 30 or 40 *Toises* only; who will deny that it may be very conveniently done by *Slings*? Provided they are always ordered and directed in the same manner as our Mortar-Pieces, when we would shoot *Bombs*, great *Grenado's*, and other *Pyrobolical Balls* from them to little Distances; that is, you must allow them the same Elevation; which is a Dexterity and Knack that might be easily acquired, partly by a previous Knowledge in *Gunnery*, and partly by continual Practice; for it was doubtless by Use and Custom that those Foreign Nations attained such Skill in handling the *Sling*, as enabled them to do such mighty Exploits, and to perform such terrible Execution with it as they did.

I must confess, this is a Point which requires some Prolixity in the treating of it, but because I do not think this a proper Place for such a Discourse I shall proceed farther on: And in the mean time only observe in what manner, the *Slings* being loaded with a *Hand-Grenado*, the Slingers may so contrive as to project them from the Trenches into the midst of their Enemies. In order to this; lodge your Slingers upon the most advanced part of the *Lines*, in some Place where they may be in Safety, and under the Covert of a good *Parapet*; as for Example, in some *Redoubt* whose distance from the Top of the Gabions on the Enemy's *Parapet* shall be 500 Foot. Now that we may not seem to be too hard upon our Soldiers, whose Arms are not yet formed to this Exercise, and that they may not think we would impose Impossibilities on them, we will suppose that our *Hand-Grenado's* cannot be thrown to a greater Distance than 100 Foot; therefore (according to what we said above) if they be projected at an Angle of 45 Deg. they must describe a Curve of 1000 Foot: But as a Distance of 500 Foot requires that the Arm of the Slinger should deliver the *Grenado* at an Angle of 10 Deg. (or $\frac{1}{4}$ of a Quadrant) beginning from the Center of the Arm that slings; therefore if the Slinger stands upon the Spot which terminates the Distance of the Place as aforesaid, at 15 Foot from the *Parapet* of the *Lines* of Approach, and if from that same Point there be a Stake planted whose Height exceeds the measure of the Slinger from the Sole of his Foot to the Center of his Arm by 2 Foot 8 Inches, and whose Position is perpendicular and directly opposite to the place where you send your *Grenado's* (or else they will go wide of your Aim,) and if the Slinger remains fixed in that Point, and after having fired the Fuze of his *Grenado* in the Purse of his Sling, he gives it one Turn only, and then throws it towards the besieged Place, in such a manner that the *Grenado* (every time he delivers one) almost touches the Top of the said Stake, and if he has always the End of it for a Mark, he will never fail of sending his *Grenado's* to the Place they are designed for; provided they are of equal Weight, and that their Fuzes are so ordered, as not to fire them before they are arrived at the intended Length. Now the
Fire

Fire of your Fuze will never go out if you fill it with one of the *Compositions* that we have given above, which I can venture to assure you of, having often used them with Success for the Fuzes of great Shells that are shot from *Mortars*, whose Motion you may believe is none of the slowest.

R E M A R K I.

By what we have said of the *Stake* driven perpendicularly into the Earth, you are to understand that the Height of 2 Foot 8 Inches, over and above the Height of the Man from the Sole of the Foot to the Center of the Arm, is a Perpendicular in a rectangled Triangle, whose Base is 15 Foot: The Angle intercepted between the Base, which begins in the Center of the Arm of the *Slinger*, and the *Hypothenuse*, which is the Hand that is lifted up with the *Sling*, is exactly 10 Degrees to which Angle, the Perpendicular beforementioned is directly parallel or opposite. The farther the *Slinger* removes from the Perch or *Stake*, the longer will the Perpendicular be; and on the contrary, the nearer he approaches to it the shorter. What I have here said, is by way of Example only, inasmuch as Bases of various Lengths require different Perpendiculars.

R E M A R K II.

You must measure the Distance between the *Slinger* and the Tops of the Gabions on the Enemy's Ramparts in such manner that there may be a Space of 15 Foot more or less between him and the *Parapet* of the Lines of Approach, which Base shall be terminated by the *Stake* above-mentioned; lest measuring the Distance from the Inner Height of your Parapet, you be obliged to expose yourself to evident Danger, by planting the said *Stake* on the other side of your Gabions: But this may on the other hand be done within the Besieged Place.

R E M A R K III.

The Strings or Reins of your *Slings* may be of Lengths suitable to the Distances of Places, according to the Practice of the ancient Inhabitants of the *Balearic Islands*, who knew very well how to lengthen and shorten their *Slings* as occasion required, if we may believe † *Florus*, who tells us, *Upon Warlike Occasions they use three Sorts of Slings, so that it is no wonder they are such good Mark's-Men, especially when we consider they have no other Arms, and are trained up to the Sling from the Cradle; and to barden them, it is the Custom of the Mother never to give*

† Flor. Lib. III. Cap. VIII.

ber Child any Victuals till she shews it him with a good Blow. But let us hear what *Strabo* says of these Islanders; They carry three Slings twisted about their Heads, the Reins of one of which are very long for great Distances; of the other very short, for small Distances; and of the third of a middling Size between the two former, for middling Distances. *Diodorus* would have them wear the Shortest round the Head, the Longest like a Girdle round the Middle, and carry the Middling one in their Hands.

R E M A R K IV.

Nothing can be more convenient or certain for throwing *Hand-Grenado's* than the *Sling*; for we have often observed, that when they are shot from *Machines* like *Mortars*, they are apt to break before they are projected, to the great Damage of the *Machine*, and Danger of the Persons who play it. If on the other Side they are delivered from the Hand only, what Disasters are not those liable to who are obliged to do it; besides those to which they are already exposed? The several Sieges of our Time have all furnished us with dismal Instances of the Ruin and Death of many a brave Fellow, to whom this Iron Fruit was more fatal, than hurtful to their Enemies: In good Truth, if my Master was here who taught me the first Rudiments of this *Noble Art*, he would be very ready to back what I have here offered, and (I dare say) would tell you, that if it had been the Custom in his Time to throw *Grenado's* with a *Sling*, he had never lost his Right Hand. Besides the *Sling*, I approve very much of certain little *Machines* not very unlike the *Balista* of the Ancients; such as we have already described; therefore I shall cursorily touch upon them.

We shall in the following Chapter treat of the great *Grenado's* that are usually projected from *Mortars*; but I must by the way take Notice that they may be very conveniently shot from the *Balista* of the Ancients. I shall in Book I. Chap. I. of the *Second Part* of our *Artillery* dwell upon the Power and Effects of those *Machines*, where I shall confirm what I say with the Testimony of several good Authors; and give you the Profils and *Scenographical Figures* of them, most curiously and exactly drawn, and occasionally explain how the Ancients were wont to construct them. Be satisfied at present with what † *Josephus* tells us of the incredible Power and Strength of the *Balista*, in his Account of the Destruction of *Jerusalem*; where he saith, That every Stone was of a Talent Weight; and did Execution not only at Hand, but to the Top of the Walls and Ramparts, though it were at a Furlong distance; and where it fell it carried a whole File before it. And † *Diodorus*; *Demetrius* placed in his * *Helepolis* several *Machines*, the greatest of which carried Stones of three Talents. *Athenæus* also speaking of King *Hiero's* Ship which was built after a

† *Joseph. Lib. VII.*
now understand by a Battery.

† *Diod. Sicul. Lib. XX.*

* This nearly answered to what we

Model contrived by *Archimedes*, relates, † *That in this Ship they erected a Platform or Battery, from whence with their Engines they shot Stones of three Talents Weight, and at the same time a Spear or Javelin of 12 Cubits in Length, to the Distance of a Furlong.* This is very wonderful, and almost incredible; but I fear I begin to tire you with this Subject; and indeed, I think, I have here said enough, to inform you of the Weights and Distances which the *Balistæ* formerly carried, and to shew that the Things shot from them were very near equal to our greatest *Grenado's* or *Bombs*, and if I had affirmed them to have been much larger and heavier, I believe I should not have exceeded the Bounds of Truth. We shall take a proper Opportunity of treating at large on the Uses and Conveniencies of these Machines, where we shall make it appear, that it would be very proper to introduce them into Modern Practice with our other *Engines*.

C H A P. II.

Of Bombs and Grenado's that are usually projected from Mortar-Pieces.

IF we consider the greater Sort of *Grenado's* in point of Form, we shall find them to be of two Kinds, (*viz.*) Round, and Spheroidal; which last we commonly call *Bombs*. Though *Boxhornius*, in his History of the Siege of *Breda*, calls those also *Bombs* that are of a Spherical Form; for he mentions them in these Terms, after having described the *Hand-Grenado's*. *Bombs of the largest Sizes that were one or two Foot Diameter did the same Execution, They were shot into the Air from Engines, and fell upon the Places they were designed for.* But if I am not mistaken, he here confounds the *Grenado's* with the *Bombs*; for he in another Place says as much of *Grenado's* as he does here of *Bombs*, (*viz.*) *They were obliged to erect Batteries at various Distances from the Counterscarps; according as the Exigence of Affairs required, either to cover their People, or stop the Sallies of the Enemy, to ruin their Machines, demolish their Batteries, and dismount their Cannon. That upon the Batteries they erected, they mounted more or less Artillery with some of those Machines (meaning Mortars) from whence they shot Grenado's, which burned and threw down every thing within their Reach.* (He then distinguishes these from the *Hand-Grenado's*, by saying) *That the lighter and lesser Sorts were thrown by the Soldiers.* As an Historian, I do not disapprove of what he here says; (the true Knowledge of these Matters being reserved for *Pyroballists*;) I shall only observe that most *Pyrotechni-*

† *Athen. Lib. V.*

cians call those Balls that are Hollow and Spherical, *Grenado's*; and that those which are Longish and Oval, they call *Bombs*.

Fig. 113. You have these round *Grenado's* represented in Fig. 113, and the long Fig. 114. ones in Fig. 114.

To these two we have added a Third of a Cylindrical Form, which Fig. 115. you have in Fig. 115; it has a firm Tompion beneath, which serves to press down and confine the *Powder* in the Chamber of the *Mortar*, in the same manner as the Tompions which are commonly used on those Occasions do. It is not long since these *Grenado's* were put in Execution; for some of those who were present at the memorable Siege of *Rochelle*, in the Years 1627 and 1628, by *Louis XIII.* King of *France* and *Navarre*, have related to us the strange Havoc they made, and how greatly they annoyed the Besieged: All which was ascribed to the great Knowledge and Skill of the worthy *Henry Clarmer* of *Noremburg*; to whom no Body can deny one of the first Palms, deservedly bestowed on the Heroic Warriours, who wrought such Wonders at that remarkable Siege, without doing the least Injustice to the Merits of *Pomponius Targon*, who was at that time chief Engineer to his most Christian Majesty.

But there have been some odd-turned Spirits, who have had Impudence enough to rob those great Men of the Honour they achieved in the Conduct of so long and so laborious a Siege, and who have endeavoured (urged by an unaccountable Envy) to ascribe to themselves what was due to those illustrious Persons; and they have so far gained their Point, as to insinuate a good Opinion of themselves into the Credulous and Ignorant, who esteem them to be in Reality what they only are in Appearance: But a time will come when they will receive a Chastisement adequate to their Unworthiness; for Divine Justice leaves no Crime unpunished, and will certainly take Vengeance of them for their fraudulent Dealing; in so ungenerously assuming that to themselves, which had been purchased by others at so dear a Rate. But let us return to our Subject, and consider after what manner we are to proportion, prepare, and use the two First Sorts of *Grenado's*.

There are those who allow the Thickness of Metal, for *Iron Grenado's* and *Bombs*, $\frac{1}{8}$, $\frac{1}{6}$, or $\frac{1}{4}$ of their Diameters. The Vent ought to be $\frac{1}{3}$, as well for these as *Hand-Grenado's*. Near the Vent they have two Ears or little Handles, by which they are lifted into the *Mortar*.

The Fuze of the said *Grenado* shall be $\frac{1}{4}$ of its Diameter in Length, though some *Pyrobolists* allow it but $\frac{1}{2}$ only. Its Diameter at Top shall be $\frac{1}{2}$ or $\frac{1}{4}$, but beneath it shall be but $\frac{1}{4}$ only. The Depth of the Cavities in the Fuze shall be $\frac{1}{16}$ of the same Diameter, as usual; you Fig. 116. have this Fuze represented in Fig. 116. But the whole Mystery is to know of what Dimensions to bore the Fuzes; for there is a certain limited Time, at the Period of which the *Grenado* is to perform its Effect, according to the Distances of Places, and according to which the

Mortar

Mortar is elevated to different Degrees of the Quadrant. It is moreover necessary to know with what *Composition* the Fuze ought to be filled upon different Occasions, that the Shell may not break till it is very near the Ground. But as this is an improper Place to dwell upon these Particulars, which bear an immediate Relation to the Artificial Construction and Use of our *Warlike Machines*, I shall reserve what I have to say of them for the *Second Book* of the *Second Part* of our *Artillery*, where I shall in the most ample manner display the Construction of *Mortar-Pieces*, their Properties, and particular Uses: And if it be the Will of Heaven, I shall produce sufficient Arguments in Behalf of every thing I lay down, and shall make it my utmost endeavour by no means to deceive our diligent *Pyrobolist*: But let us proceed to the Sequel of this Essay.

These Fuzes shall be re-inforced without, with dried Sinews, spread out like Tow, then steeped in hot Glue; and within them you shall stick some Threads of *Quick-Match* here and there, for fear the Fuze should unluckily go out, by the Violence of the Wind or Air during the Flight of the *Bomb*: In short, the Fuze being filled with a suitable *Composition* (such as we gave in the foregoing Chapter) you shall drive it into the Vent of the *Grenado* or *Bomb*, which must be filled with good *Corn Powder*, in the same manner as we directed in reference to *Hand-Grenado's*.

Observe here, that you must never use a Shell till you have tried whether it be sound and whole, which you may know by the following Proof: Bury your Shell under burning Coals to make it red-hot; and having acquired that degree of Heat, take it from under the Fire, and pour cold Water into it before it is cooled, and stop up the Vent, to prevent the Water from getting out; then instantly anoint the whole Convexity of the Shell with Butter of *Antimony*, or with Soap moistened with a little hot Water; if it is cracked or defective in any Part, you will see little Bubbles, or Blisters, rise, fall, and disappear by turns. If you perceive any thing of this Nature upon the Surface of your Shell, I would have you throw it aside if you have any better, as both useless and dangerous: But if the Situation of your Affairs obliges you to use such, for want of better; you shall take particular Notice of the Cracks or Flaws if they are visible, and if not, you shall remark those Places where you saw the Blisters rise; or if they are little Holes that are conspicuous, you may stop them with Steel Nails. This done, coat your Shells over with Tar or Fitch, or some of our *Pyrotechnic Cement*, and then cover them well with Tow steeped in the same Stuff, the *Composition* of which we gave in the above Chapter. Finally, wrap them tightly round with a strong Cloth. You must exactly observe these Particulars without omitting the least thing in the World; for fear the *Grenado* should meet with any Accident from the *Fire* of the Fuze during its Flight.

You may find the Requisite of *Powder* for projecting your *Grenado's*, by what I am now going to say: But first of all it will be necessary for me to tell you, how to come at the Weight of a *Grenado*, purely by the Assistance of an *Arithmetical Calculation*, and by means of our *Calibre Scale*, which is the most ready Step towards finding expeditiously and certainly the Quantity of *Powder* requisite to shoot out your *Grenado*. This you may work after the following manner.

Take the Diameter of a *Grenado*, and apply it to that Side of the *Calibre Scale* which is designed for *Iron Bullets*; and consequently one Foot of the Compasses will fall upon a Number, answering to the Weight of the *Grenado* if it was solid. Set down this Number upon a piece of Paper, or at least take care to remember it. Then take the Diameter of the Cavity of the same *Grenado*, and applying it in like manner to the *Calibre Scale*, one Foot of the Compasses will point out a Number expressing the Weight of that Cavity if it had been solid, and of Iron. Then subtract this last Number from the first, and the Remainder will give you the Weight of the Shell of the *Grenado*.

If you should meet with a Diameter which extends beyond the Length of the *Calibre Scale*, you shall apply the Half of it only to the said *Scale*, and the Number it reaches to being multiplied by 8, the Product will give you the Weight of the whole *Grenado* had it been Solid. As for Example; be there given the Diameter of a *Grenado* that cannot be measured by the Extent of the *Calibre Scale*; the Half of which being applied to the said *Scale* reaches to 18: This Number being multiplied by 8 will produce 144, which would be the Weight of the *Grenado* had it been solid: Then taking half the Diameter of the Hollow or Cavity of it, and applying it to the *Calibre Scale*, suppose it to extend to 7: Let this Number be in like manner multiplied by 8, and it will produce 56. In short, this last Number being subtracted from 144, you will have a Remainder of 88, for the Weight of the Shell of your *Grenado* or *Bomb*.

You will find the Quantity of *Powder* necessary to fill your *Grenado*, if you measure the Cavity of it with a certain Line or Scale of *Powder*, *Stereometrically* divided into *Pounds* and *Ounces*, such as you see distinguished by A in *Fig. 117*; upon which the Number which falls under the Foot of your Compasses, will express the Number of *Pounds* or *Ounces* of *Powder* which the Cavity of the *Grenado* is able to contain; add now this Weight of *Powder*, to the Remainder of the last Subtraction, which gave the Weight of the Shell, and you will have the whole Weight of the *Grenado* when filled with *Powder*. I will now instruct you in the Construction of this *Scale*. Fill some perfectly round *Grenado* with *Corn Powder* up to the Vent, then pour it out again, and weighing it, set down what it weighs. Then measure the Cavity of the said *Grenado*, and divide the Diameter of it *Stereometrically* into as many Parts as the *Powder* contains *Pounds* or *Ounces*: This you may readily

readily do by observing the Rules in our First Book; and upon such a *Scale* you may mark out the Diameters of several *Pounds*, or *Ounces* of a *Pound*, or half *Ounces* if needful.

But if you should not have *Grenado's* just at hand, whereby to form this *Scale*, get an hollow Wooden Cylinder of what Size you please equal in Height and Breadth, and filling it with *Corn Powder*, pour it out again, and weigh it. Now as every Cylinder that contains a Sphere is in a *Sesquialteral Proportion* to it, according to *Archimedes*: Therefore must you say as 3 is to 2, so is the Weight of the *Powder* contained in the Cylinder, to the Weight of that which would be held by a Sphere, included in the same Cylinder. This done, you will have a Number in your Quotient answering to the Weight of a *Globe* of *Powder*, supposing the Diameter of such a *Globe* to be equal to the Height and Breadth of the Cylinder. This may be done by any Body, that is never so little skilled in *Geometry*.

Sometimes *Pyrobolists*, by way of Diversion or Experiment, fill *Grenado's* with Sand, thereby to come the more easily at their true Weight: Which done, they put them into *Mortars*, and taking their Sight at Marks at certain Distances; they shoot them off, and observe their Falls: Upon which Account it is necessary to know the Proportion which the Weight of *Sand* bears to that of *Powder*. For my part, I have often experimented that very Fine, White, Dry Sand, bears such Proportion to fine *Corn Pistol-Powder* as 144 does to 83. Upon this Foundation I have formed another *Scale* which you see distinguished by B for  Fig. 117. *Globes* of *Sand*. By this Line you may know how many *Pounds* of *Sand* would fill each *Grenado*. But if you would take only just so much *Sand* as is equal in Weight to the *Powder* which fills the *Grenado* (in which *Pyrobolists* are very exact) you must find out the Quantity required by means of the proportional Numbers above: But that *Ratio* will not always obtain; for the Weight both of *Powder* and of *Sand* may be infinitely varied; for as the *Ingredients* of *Gun-powder* are mixed a thousand ways, you may readily suppose that it differs much in Weight; and on the other hand, the several sorts of *Sand* are infinitely unequal in point of Gravity: But those who are desirous of being perfect in our *Art*, will have the Patience to examine the Gravity of different Sorts of *Sand*. Having shewn you the way how to come at the Weight of *Grenado's* filled both with *Powder* and *Sand* (as I proposed) without the help of any weighing Instrument; I shall advance farther on.

Now this Weight being found, it will be very easy to find the Requisite of *Powder* for charging your *Mortar*. But to say the Truth, this is a Point which cannot well be determined; for *Pyrobolists* change and vary it very often, as Occasion requires; being obliged sometimes to take more, sometimes less *Powder*, according to the Distances of Places. Most commonly they take half an *Ounce* of *Powder* for every *Pound* that the *Grenado* weighs; and in some Cases they take but a Quarter of an *Ounce*,

Ounce, and at other times but $\frac{1}{2}$ of an Ounce, and sometimes less, particularly when they would project their *Grenado's* so as not to be above 4 or 6 Seconds at most before they fall at perhaps the Distance of 10 or 15 Paces, and in their Projection borrow more upon a strait Line than a Curve. This is usually done when the Besieged see the Enemy preparing to make their Galleries, or perceive them obstinately bent upon passing the *Fossé*, by any other means, in order to gain the Foot of the *Rampart*; it is then that the Use of *Mortars*, *Grenado's* and *Bombs* is not forgot. I must own however, that the same thing may be done with a greater Quantity of *Powder*; but then it would be attended with this Inconveniency (namely) That the *Grenado* being projected with the greater Violence, it would be obliged to go through a greater Space, and consequently remaining longer in the Air, it would give those who see it, time to get out of the Danger of it before it can fall. I must also remark, that you may throw *Grenado's*, *Bombs*, &c. at several Distances with one and the same Quantity of *Powder*; by means of the Elevation of the Piece above the Plane of the *Horizon*, and also by the Declination of it from the Vertical Point or Zenith to an Angle of 45 Degrees, which Position is the most natural to *Mortars*. This may not be an improper Hint; for I am really of Opinion, it would be by much the best and most certain (were it not for some insurmountable Difficulties and Circumstances which oppose it) to take certain Quantities of *Powder* in proportion to each Distance; by which means the *Machines* being elevated but a few Degrees above the *Horizon*, would always have their Position very low, which would be never, or very seldom changed. However as this cannot be easily practised, or indeed not at all, for every Distance; yet methinks I would have the great *Machines*, whose Elevations borrow the nearest upon the Vertical Point, and which are usually chosen for the shortest Distances, deprived of a little of their usual Requisite of *Powder*, and in Recompence for that Loss, inclined a little more to the *Horizon*.

But not to stop here, and that we may conclude upon something certain with regard to the Requisite of *Powder*; I have established and ascertained a Quantity, that may generally speaking dislodge the *Military Projectiles*, be their Weight what it will: In order to this, I have constructed a little *Table of Requisites* (which we shall dwell more particularly upon in the Second Part of our *Artillery*) which I hope may be successfully put in Practice. I say it will be sufficient if for *Balls* or *Bombs* of great Weight, as 300 lb or more, (if there are any such,) you take half an Ounce of *Powder* for every Pound. This Proportion may be observed for *Projectiles* down to 100 lb: But from 100 lb to one lb, you shall increase every Quintary that is every Fifth Number with 15 Grains; so that you may have 588 Grains of *Powder*, which are 2 *Loths* and 12 Grains, to project a *Ball* of one lb. Upon this Foundation I have calculated a little *Table of Proportion*, from 100 lb down to one lb.

There

There is nothing that can be more plain or easy than the Use of it; for you need only multiply the Numbers of the Column B by the Numbers of the Column A, and divide the Products by 288 in order to have the Requisite Number of *Lotbs*; (for a *Lotb* contains just that Number of *Grains*;) which Number of *Lotbs* being divided by 32, you will have the *Pounds*: But that you may have a perfect Apprehension of this, I shall illustrate it by an Example. Suppose you have a *Ball* of 80 lb which you would project: Look first for 80 in Column A; and having found it, multiply it by the opposite Number in Column B (*viz.*) by 348, and you will have a Product of 27840, which will be the Number of *Grains* of *Powder*; which being divided by 288, will give 96 *Lotbs* 8 *Den.* in the Quotient; each *Denier* 24 *Grains*. In short, these *Lotbs* being divided by 32, will give 3 lb. You must then take 3 lb and 8 *Deniers* of *Powder* to charge the Chamber of the *Mortar*, from which you would project a Body weighing 80 lb.

The following *Table* will help you in the Difficulties which may occur in this Case; provided that you have a right Conception of this Example.

A TABLE of Requisites of Gun-Powder.

A	B
100	288
95	303
90	318
85	333
80	348
75	363
70	378
65	393
60	408
55	423
50	438
45	453
40	468
35	483
30	498
25	513
20	528
15	543
10	558
5	573
1	588

OBSERVATION I.

To every Number between the Quintaries of this *Table*, you shall successively add 3 *Grains* for every *Pound*. This done, multiply the Sum of that Addition by the Weight of the *Projectile*. As for Example, if you meet with one that weighs 82 lb, you will find it less by 3 than 85, the superior Quintary of the *Table*; having then added 9 (which is 3 for each *Pound*) to 333, you will have 342; this 342 being multiplied by the Weight of the *Projectile* which is 82, the Product will be 28044; which being divided by 288, you will have 97 *Loths*, 4 *Deniers* and $\frac{1}{2}$.

OBSERVATION II.

The Rule here laid down for the *Projectiles* which are shot from *Mortars* ought to be followed as universal and immutable: But at the same time Allowance must be made for the different Strength of *Powder*; inasmuch as one *Ounce* of some sort of *Powder* will do twice, nay, ten times the Service as an equal Quantity of some other Sorts; and consequently one *Ounce* of the former will be as strong as 10 *Ounces* of the latter. But I leave this Article to the Consideration and Judgment of good Practitioners; and shall go on to the loading of our *Mortars*.

Suppose now, you have the Requisite of *Powder* for projecting a *Grenado* from a *Mortar*: You shall in the next place measure the Height and Breadth of the Chamber by means of a *Cylindric Scale*, or rather a *Cylindro-metric Scale*, divided Cubically, and adjusted to the Weight of *Gun-powder*, such as you see in *Fig. 117* in the Letter C. Now if it happens that your Chamber is equal in Height and Breadth, you may conclude that it holds as many *Pounds* of *Powder*, as the Number it cuts upon your *Scale* contains Unities: But if on the contrary its Height and Breadth are different, you must find out a mean Proportional between them, which may give you the true Capacity of the Chamber. If these Numbers should happen to be Surds, you may find out a mean Proportional between them by Lines much better than by Numbers.

If the Chamber of your *Mortar* is bigger than necessary; first put your *Powder* into the Chamber, and measure the Vacancy of it above the *Powder*: Divide this into 6 equal Parts, and add $\frac{1}{6}$ to its Height; and you will have the true Height of a Wooden Tompion; by which the *Powder* in the Chamber will be sufficiently compressed, so that the Flash will have no room to expand itself, and will consequently act with its full expulsive Vigour: But if on the contrary the Chamber of your *Mortar* is too little to hold the Requisite of *Powder*; divide the Height of it into 10 equal Parts, and fill it up with *Powder* to $\frac{9}{10}$, and ram it with a Tompion of $\frac{1}{10}$. And in this Case the Rule we have given above can be of no Use.

You

You must proceed after this manner when it happens that your *Powder* fills your Chamber so exactly as to leave no room for a Tompion; but you will be better instructed in every thing relating to this matter by the Sequel.

The Wooden † Tompions for confining the *Powder* in the Chambers of *Mortars* are prepared after different Fashions; for if you would fix your *Grenado* in such a Posture as to have its Fuze turned outwards towards the Muzzle of the *Mortar*, and if you would project it by one Fire only, your Tompion should be fluted like a Pillar, as you may observe in Fig. 118 by the Letter A; or pierced through with Holes at Fig. 118. Top which terminate in a large one at Bottom, as may be observed in B. I must here remark, that it is by much the safest Way, to project your *Grenado's* by means of one *Fire* only; in doing of which you are to observe the following Order.

After having loaded your Chamber with the Requisite of *Powder*, and driven the Tompion upon it, so as in no degree to surmount the Edge or Rim of the Chamber; you shall fill up the Holes in the said Tompion, or the Flutings round it, with good *Meal Powder*, and salt it over with a good handful of the same; then wrap up your *Grenado* in a Felt, or a coarse Woollen Cloth, well soaked in strong Brandy, mixed with *Meal Powder*; this Coat or Covering shall be open at Bottom, of the same Breadth as the Orifice of the Chamber. This done; fix your *Grenado* in the *Mortar* in such manner as to bear upon the Tompion.

The Fuze shall be well garnished round, with some of our loose *Quick Match*; and the whole Body of the *Grenado* shall be well salted over with *Meal Powder*, to facilitate the Accension of the Fuze.

This is the first Way of projecting *Grenado's* from *Mortars* with one *Fire* only. The Second does not differ much from it, excepting that it is much the more dangerous of the two; for here the Fuze is turned inwards upon the Chamber; and in this case you must have a Tompion with an Hole in the Middle of it, and divided into 4 equal Parts by means of two Diameters intersecting each other at Right Angles, as you see in Fig. 118 by the Letter C. However I would by no means have this practised for ordinary *Grenado's*: But I would have them ordered as you see in Fig. 119, where the Vent and Bottom are turned into Fe- Fig. 119. male Screws, which shall have an Iron Fuze with a Screw at Top and Bottom to be inserted into them, as may be seen in A: But I must tell you that these Screws cannot be too nicely fitted to each other.

If you would rather chuse to project your *Grenado* by means of two *Fires*, you shall have a solid Tompion. This Tompion being driven into the Chamber, you shall cover it with a fresh green *Gazon* or Turf, or something of that kind, which shall be covered with a round Board of 2 or 3 Inches thick, but a little less in Diameter than the Calibre of

† These Tompions are found to be useless,

the *Mortar* (see Letter D.) To conclude, you shall fix your *Grenado* upon it with its *Fuze* turned outwards, and cover it with a *Gazon*; after having stuffed the Vacancy between the *Shell* and the *Mortar* all round with Hay, Straw, Tow, or Mold, to keep the Shell fixed and firm.

Fig. 120. This last Method is very particularly represented in Fig. 120, to which I refer you, if you do not apprehend my Explanation.

C O R O L L A R Y.

To tell you now who first invented, or who first practised this destructive Contrivance, which has been promiscuously the Ruin of such Numbers of Men, and the Overthrow of so many of the most beautiful Buildings, most magnificent Cities, and strongest Walls and Fortifications in the World, is a Task unequal to my Knowledge; for we do not find the least Mention made of the Person in any History. Indeed in several reputable Authors we have an Account of the Times and Places, when and where this infernal Invention was first put in Practice; the Testimony of whom I shall here insert, notwithstanding that they differ pretty much from one another. But as to the Inventor himself, we do not find the least Mention made of him; which I cannot help being surprized at, since it seems to be a very great Injustice to Posterity to conceal the Name of so great an Engineer from it. In truth, I know not what to say or think of such a Procedure, and should be glad to know whether it was thro' Chance or premeditated Design, that the Writers of those Times have left us in the dark as to this Matter: But every one may judge of it as he pleases, for my part, I can only here entertain such as are wholly Strangers to the History of this Invention, with what can be gathered from the Testimony of several Authors. *Tbuanus* says,

† *All the Stratagems of the Duke of Parma before Bergen op Zoom proving ineffectual, and despairing to carry it, and considering that the Season was very far advanced, and that the Low Country was almost overflowed; and finding that the Garrisons of the Island of Tretole, by their continual Excursions and Depredations, made Provisions very scarce and dear in his Army, he resolved to raise the Siege, and send his People into Winter Quarters, and accordingly he distributed some of his Troops in Turenhalt, Rosendal, and the Country of ‡ Campen, and sent the rest to join the Troops which were under the Command of Prince Ernest Mansfelt at the Siege of Bon, to block up Watchtendonck, which is an ancient Town of the || Sicambrians, situated upon the Niers not far from the City of Gueldres. This was done, at the earnest Entreaty of the Inhabitants of Ruremond, who begged to be delivered from the troublesome Excursions*

† Thu. Lib. LXXXIX. Pag. 263. A. D. 1588. ‡ This is now most commonly called Zutphen.

|| The People of Gelderland were anciently so called, and the Country itself was called *Sicambria*.

Fig. N^o 102.

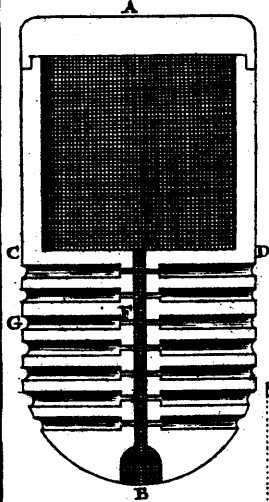
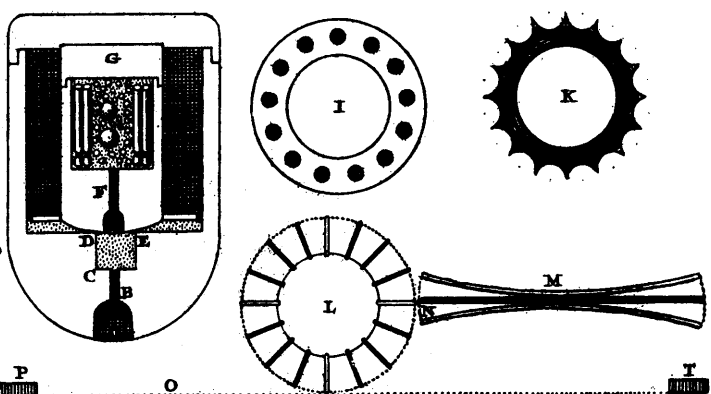

Fig. N^o 103.



VIVÉLEROY

Fig. N^o 104.

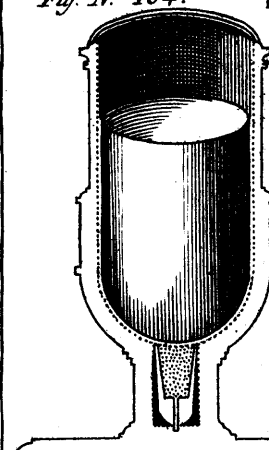

Fig. N^o 105.

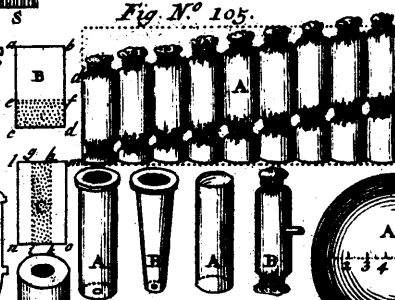
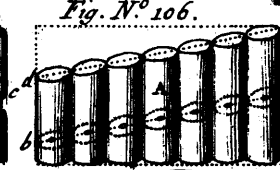

Fig. N^o 106.



N^o 107.

N^o 108.

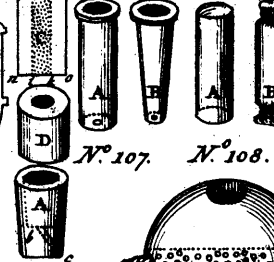

Fig. N^o 109.

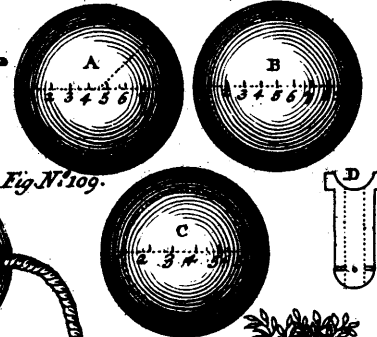

Fig. N^o 112.

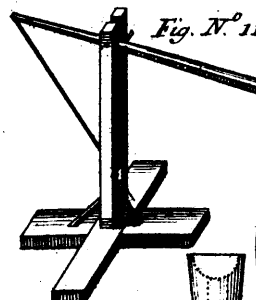

Fig. N^o 111.

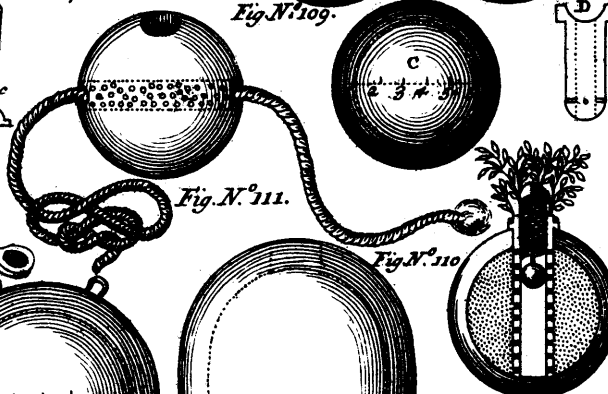

Fig. N^o 110.

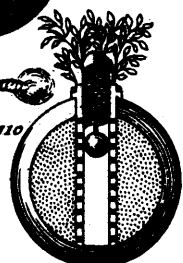

Fig. N^o 116.



Fig. N^o 117.



Fig. N^o 113.

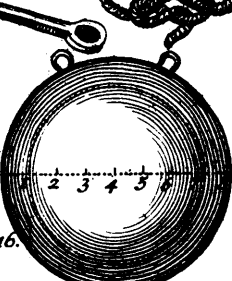

Fig. N^o 114.

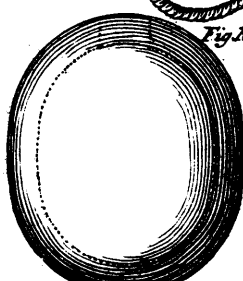
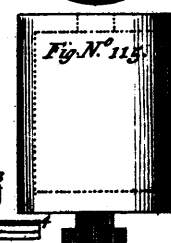

Fig. N^o 115.



fions of the Robbers (it was thus they called the Soldiers of the neighbouring Garrisons.) Towards the end then of October the Place was invested, under the Conduct and Command of the aforesaid Mansfelt. The Pioneers advanced and raised Batteries of Gazons or Sodds, upon which they mounted their Cannon, which played upon the Town till they threw down the Roofs of the Houses, and all the lofty Buildings in it. But they did not only (says he) ruin them with their Cannon, but they also galled them with Grenado's and Balls filled with combustible Matter, which they shot among them with certain Engines, so that the poor People could hardly find Safety any where, from the horrid Tempest which was showered down upon them. He adds, That these Balls were made hard by, at a small Town called Venlo; and that the Inventor of them, resolving to make Proof of his Work, at the Celebration of a Festival designed for the Entertainment of William the young Prince of Cleves, he had no sooner set Fire to them, than they had an Effect quite contrary to what he intended; for the Town was fired by them, and was very near half destroyed. A melancholly Diversion!

This Author has hitherto pretty well informed us of the Place where our Missive Thunder was invented, and of the Time it was first put in Execution. But another Writer, who equally deserves our Credit, (namely) *Reidanus*, who has left us the History of the *Low-Country Wars in Latin*, seems to be of a quite contrary Opinion as to this Point. He speaks thus: † *Adolphus Nivenarius, Governor of Guelders, resolved to keep up the Scarcity of Provision as much as he could, and to starve the Inhabitants of Bergen, if possible. But unhappily as he was proving his Bombs, with which he had determined to destroy the Enemy's Ammunition, he was greatly astonished, to find that upon being fired they blew up the Arches and Vaults of the Castle of Harnem, together with several other fine Buildings. A brave Officer called Denis, and another Gentleman, perished by this Accident: And the Earl himself could not escape the Fire, for being cruelly burnt, he died a few Days after. Almost such another Accident happened the Year before, (he means 1587) at Bergen op Zoom; but of a more extraordinary nature. A certain Italian who deserted from the Duke of Parma, fled to the Confederates, to whom he pretended, that he had an admirable and un-heard of Invention for preparing hollow Vessels and Globes of Iron and Stone (sure this was a thing impracticable, and I believe every Pyrotechnician will think it impossible to contrive so as to make Stone effectual in such Works: But he goes on) which might be easily thrown amongst the Enemy; where they would do most terrible Execution by Thousands of Splinters, which would fly from them in bursting, and besides, that the least Spark of them would infallibly set fire to whatever they touched. But the Instant that our Grenadier was busied in carrying on his Project, a Spark of Fire unfortunately fell upon the Table where he had prepared his Composition; and as he was going*

† Reid. Lib. VIII. Page 182.

hastily to take it away, the Fire (which loses no time) got hold on his Hand. He, astonished to see a Glove of Flame upon his Hand, and not knowing what to do to get rid of it, clapped his Hand between his Thighs to stifle it, but far from being suppressed it laid hold on his Breeches, and from thence penetrated to his Thighs: In a Word, his Hand was instantly stript of both Skin and Flesh. Vinegar proved ineffectual, and instead of extinguishing rather increased the Flame; to conclude, the Fire spreading over the rest of his Limbs, the unhappy Man expired in less than three Days, after having suffered the most severe Pains without Intermision or Relief.

To the Testimony of these two grave Authors, I shall add that of a Third, whose Fidelity is unquestionable, I mean *Famianus Strada*, who speaking of the *Low-Country Wars*, writes to this Effect, † *There was nothing which more astonished the Enemy (he here means the Attack of Mansfelt at Wachtendonck) than certain great Brass Globes hollow within, which were filled with Powder and Sulphur, and other inextinguishable Things; which were shot from great Mortars, with little ‡ Ropes in a small Hole, which by their Weight, and Violence of their Fall, threw down the greatest part of the Buildings; and what is the most strange of all, when they were lighted their Flame caught hold on every thing within its reach, with such Obstinacy that no Water could extinguish it. These Globes, which gave the first Hint to the Invention of Grenado's, Fire-Pots, and such like Instruments of Death, were invented (as we are told) by a Man at Venlo a little before the Siege of Wachtendonck; though he happened to be the Destruction of his own Town: For upon a Day that the Inhabitants of Venlo made an Entertainment for the Duke of Cleves, this consummate Artist making Experiment of his new Invention to divert that Prince, shot off one of them, which falling upon a large Building, broke down through it from Top to Bottom, and setting it in a Blaze, the Fire ran over all the Neighbourhood, so that in a very little time two Thirds of the Town were laid in Ashes. I know a certain Author (he means *Reidanus*) who in his History relates something of this Kind to have happened a Month or two before at Bergen op Zoom, to an Italian Defenter, who was going to make an Experiment of one of these Balls. This Renegade promised the Confederate States to make certain hollow Vessels or Globes of Iron or Stone, which being kindled, and thrown into besieged Places, should set Fire to whatever they could reach; after having broke into a thousand pieces. But by a strange Mischance, a Spark of Fire fell upon the Composition he had prepared for these Globes, and the Flame of it caught hold on him in so frightful a manner, that spreading all over him from one Limb to another, he died most miserably, after having undergone the most exquisite Torment; and left it doubtful, whether or no he would have come up to what he promised. But however that might be, it appeared that those Venlovian Engines an-*

† *Fam. Stra. Lib. X. Decad. II.*

‡ This seems pretty obscure; but perhaps instead of Fuzes, they stuck some sort of Match in the Vents of their Grenado's or Bombs.

swered very well to the Purposes of Mansfelt; for with them he committed such merciless Ravages, demolished so many fine Buildings, and killed such vast Numbers of People in the Places he besieged, that the Inhabitants could hardly find Shelter from the Tempest, which continually pursued them where-ever they went, though they retired to Cellars and the most subterraneous Retreats. The Burgeesses of the Town at length considering that this Storm of Iron and Fire, threw them into the utmost Confusion, and perceiving that it demolished all their Habitations, and that they should insensibly lose their Country, resolved to go in a Body to Lanctair their Governour, to beseech him to take some Measures towards the Preservation of their Lives and Fortunes, and to desire him to reflect seriously upon their unhappy State. Upon the whole, they alledged that they were utterly destroyed by degrees; that they had but few Buildings left standing; and added, that if the Enemy continued to ply them with their Grenado's, it would be impossible for them to subsist, or make any farther Resistance, except they built a new Watchtendonck under Ground, as they had already begun.

I must confess that what I have quoted from this Author, is a little foreign to the Point in hand: But he has expressed himself in so moving a manner of this dreadful Contrivance, that I could not help transcribing of him at length. It is from hence that the skilful *Pyrobolist* may draw Conclusions in favour of these Weapons; it is from hence that he may perceive the Necessity there is for them in the Attacks of Places in our Times; in short, it is from hence that he may judge of their great Utility to the Besiegers, by compelling the Besieged to a speedy Capitulation, by expediting the Surrender of Towns and Cities, and distressing those that are the most obstinately bent upon defending themselves.

Here I should close up this *Corollary*, as knowing that what I have quoted from these famous Historians has fully answered my Intention, which was to give an Account of the Origin of our *Grenado's*. But since in this Work I act the part of a *Pyrobolist*, I think myself obliged to clear up every thing that may be obscure in relation to the Practice of our *Art*, for the Benefit and Instruction of those who particularly apply themselves to the Cultivation of it. Let us then look back to what we quoted from *Famianus Strada*, where he has seemingly described the Form, the Properties and Effects of our *Grenado's*; and let us ask him what he means by the *Fire-Pots*, *Grenado's*, &c. which according to him derive their Origin from the hollow *Globes* he speaks of, since his Description of them agrees so nearly with that sort of Arms which are now in Use with us. If he answers, that they were a sort of *Balls*, which in his Time were called *Bombs*; (which Word I know is promiscuously used to this Day) I shall reply, that the Word *Grenado* would have suited better with them, as being a more general Term. If on the other hand he alledged, that the little ones, which we call *Grenado's*,

are

are Descendants of those great *Balls*; his Assertion will in some degree be falsely grounded; for I sufficiently demonstrated in the foregoing Chapter, that the ancient *Pyroballists* were acquainted with the small *Grenado's*, considerably before they knew any thing of the Great. Those who have the leisure, may upon this Subject consult *Leonardus Fronspengerus* in the *Second Part* of his *Military Art*; which he dedicated to *Rodolphus II*, who was at that time newly elected King of *Hungary*, and who was afterwards Emperor of the *Romans* in the Year of our Redemption 1573. But though I should grant that the lesser sort of *Grenado's* were unknown to past Times till after the Invention of the Greater, and that it was from Experience of the Nature of the Latter, that Men took it into their Heads to use the Former; yet I shall never allow that the *Military* † *Ollæ* or *Fire-Pots* are posterior to the hollow *Globes* which he speaks of, as he would have us believe. But very far to the contrary, I dare affirm that our *Grenado's* are derived from the *Fire-Pots*; and I make no scruple to say, that the *Ollæ* of the Ancients were the Lightning which preceded our Modern Thunder; and this I may safely advance, since I have the Testimony of several great Authors, who lived in unspotted Credit and Reputation amongst the Ancients, to support me in it; from whom we may gather, that the most expert Captains in former Days met with very successful Effects in their Sieges and Attacks from *Fire-Pots* not very unlike ours. We have elsewhere touched upon this, and therefore shall desist from it at present, reserving it till we come more particularly to speak of *Fire-Pots*. In the mean time (dear Reader) let what we have offered be kindly received by you; and assure yourself, that *Artificial Pots* are of very old standing, and that they are so far from deriving their Origin from *Grenado's* or *Bombs*, that it is more reasonable to believe quite the reverse. Pray hearken to what *Sextus Julius Frontinus* says of the *Fire-Pots* of the Ancients. ‡ Cneus Scipio, in a Sea Fight found out a way of throwing || Vessels full of Pitch and Pine-wood at the Enemy's Fleet, which were as dangerous in their Fall, because of their Weight, as they were hurtful on the score of the Igneous Nature of the Matter they contained which was spread abroad from them. *Dionysius* speaking of the Fireworks which were used at the Battel of *Actium*, between *Augustus Cæsar* and *Marc Antony*, observes, * That Cæsar perceiving his Soldiers very roughly handled by *Marc Antony's Party*, who cut them in pieces with their Axes and Swords, and galled them terribly with their missile Weapons, from the Advantage they had of being in taller and better-fortified Ships: He had recourse to Fire, as the best Remedy he could apply to the prevailing Evil: In short, his Soldiers gathered round him, and began to throw Fire-Darts,

† This is only a Latin Word which signifies a Pot of any sort.

‡ Sex. Jul. Fron. Lib. IV. Cap. VII.

|| The Latin has it *Amphoras*; but we must here conclude that *Frontinus* thereby means any sort of Vessels in general.

* Dion. Lib. L. de Bel. Act.

Brands and Torches, together with Pots full of Pitch and burning Coals at the Antonians, which so annoyed them in their Ships (though they took care to keep as far out of Danger as they could) that the Cæsareans got the better of them. Thus what the Force of their Arms could not obtain, they effected by Fire, and thus by means of that Element they triumphed over their Adversaries.

I could bring several other Authors to bear witnesses in Favour of the Fire-Pots of the Ancients: But I apprehend that these two will be sufficient to convince you of their Antiquity. Let us then proceed to the Construction of several other Sorts of Grenado's.

C H A P. III.

Of Grenado's that are commonly called Blind.

PYROTECHNICIANS have certain Grenado's which stand in no Necessity of being lighted when they are projected, from whence they are called *Blind*, which is a common Term amongst them, for such Grenado's and other Balls as stand in no need of being fired at the time of their Projection: But as soon as these strike the Ground, or fall upon any hard Substance, they have the same Effect as other Grenado's. Fig. 121 represents one of these Grenado's, in which the Letter Fig. 121. A is the Grenado, hollow and pierced through and through, and which has on one Side another small Hole, for the same purpose as those in the other Grenado's which we have described above.

Letter B in the same Figure points out a Barrel or Tube, made of an Iron Plate, whose Sides are full of Holes, and its Inside made rough like a File. This Barrel receives two Flints which are screwed tight in Contrivances like the Cock of a Gun-lock, which are foldered to a substantial Iron Rod, as may be seen in C. First then, this Barrel must be fixed in the Shell; its upper End passing through the *Vertex* or Top of the Grenado where it is screwed fast with a little square Plate of the Thickness of 2 or 3 Lines only, as you see in G. The lower end of the Barrel which receives the Flints shall rest upon a round Plate with an Hole in the Middle of it, as you see in E, to keep it fixed in its Position. Now the Iron Rod that has the Cocks of the Flints foldered to the upper End of it, shall have its lower Extremity turned into a Screw, to fit a female Screw in the Middle of a large round Iron Plate, as you see in D, which serves for a Foot to the Grenado and all its Furniture, and upon which it falls when it comes to the Ground.

The Letter H shews you a single moveable Cock with its Flint, ready to strike Fire, and mounted upon a Steel, which may serve as well as the two former.

If you would see this *Grenado* as it is compounded of all its Parts when set together, cast your Eye upon Letter K, where you will see it just as I have described it. You will moreover see two small Tails above, to serve it instead of Wings, which are made of old pieces of Linen, drawn through two small Irons, which are fastened to the Rings on each Side of the square Plate G; the Use of them is to make the *Grenado* fall in a perpendicular Direction upon its Foot or round Plate at Bottom.

Now the *Grenado* falling in the abovefaid Direction, the Flints in the Barrel will by the superincumbent Weight of the *Grenado* be violently forced upwards, and consequently rubbing impetuously against the rough Inside of the Barrel, will strike such a Fire, as must accend the *Gun-powder* in the *Grenado* through the Holes in the Sides of the Barrel, by which means it will have the same Effect as the former.

C H A P. IV.

Of Grenado's that are shot from large Cannon.

I Shall now describe to you the fourth and last Sort of *Grenado's*; (namely) those which are commonly shot from great Pieces of Ordnance, to tear down *Ramparts* and make Breaches, almost like those made by ordinary *Mines*, though indeed not so large or considerable. *Pyrobolists* have from time to time invented infinite Sorts of these, but I do not here undertake to treat of them all; I shall therefore only dwell upon the most serviceable of them, and such as you may trust to, without any Danger of their failing.

S O R T I.

Of the numerous Clafs of these *Grenado's*, we shall give the first place to that which we have represented in Fig. 122, which (as may be seen) is Spheroidal in its Form and hollow within. Its *Vent* is a Female Screw, contrived exactly to receive a Male Screw, which is beneath a certain Iron Socket: Into this Socket you fix a round Fuze, (or if you will it may be multi-angular) whose Sides shall be bored all round with a pretty fine red-hot Needle, in an Oblique Manner, or at Acute Angles, all which Borings must Center in the Hollow of the Fuze; by which means all their little Orifices will be turned towards the *Grenado*. All these, as well as the middle of the Fuze, must be filled with *Meal Powder*; and the hollow Screw of the Socket which goes into the *Grenado*, shall be filled with one of those *slow Compositions*, which have been given for the Fuzes of *Grenado's*. Upon this Fuze, and the Socket which receives

ceives it, you must fix four Wings, or more if needful, made of thin Copper or Iron Plates, exactly the Length of the Fuze: As for their Breadth, it shall be so ordered, that the Breadth of any two of them opposite to each other being added to the Diameter of the Fuze, they may constitute a Right Line which is equal to the least Diameter of the *Grenado*; and consequently their Breadth must be equal to the Diameter of the Fuze, which on the other hand must be equal to a $\frac{1}{2}$ of the shortest Diameter of the *Grenado*.

The Length of the Fuze must be so nicely proportioned, that being screwed into the *Grenado*, it may be in exact *Æquilibrio* with it. This *Æquilibrio* will be easily found, if you recollect what we said of the sticking of *Rockets*. In short, to conclude with this, you shall wrap the Fuze well up in loose *Quick Match*, and salt it over with *Meal Powder*, and then put it into your *Cannon*.

S O R T II.

In *Fig. 123*, you have another Sort of *Grenado* of this same Species, *Fig. 123.* which must be prepared after the following manner. You shall take a common *Grenado*, whose Diameter is a little less than the Diameter of the *Cannon* you would project it from. It must be fixed upon a Wooden Cylinder, whose Top is hollowed out in form of a Concave Hemisphere, so as exactly to receive one half of the *Grenado*; its Bottom must be flat, but its Head (which we shall mention hereafter) shall be *Conic*. You shall bore an Hole lengthways through the aforefaid Cylinder, which shall have a Communication with the *Vent* of the *Grenado*, and which you shall afterwards fill with *Meal Powder*. The Length of this Cylinder shall be $2\frac{1}{2}$ Diameters of the *Cannon*: Then clap on the aforefaid *Conic* Head, the Diameter of whose Base is equal to that of the Cylinder, and which must also be hollowed out in an Hemisphere to receive the other half of the *Grenado*. In short, the Cone and Cylinder shall be joined in the firmest manner with Pitch and Glue: Whatever relates to this, may be easily apprehended by the *Figure*.

S O R T III.

You have the third Sort of these in *Fig. 124*, the Construction of which *Fig. 124.* is very simple: You need only take a Wooden Cylinder as A, equal to the Diameter of the Piece it is to be shot from: It is first hollowed out beneath in Form of a Concave Hemisphere, so as to be able to receive half of a *Grenado* as B, whose Diameter must be a little less than the *Calibre* of the Piece: The Top of it shall be bored with several Holes, which shall all tend towards the *Vent* or Fuze of the *Grenado*; all which shall be filled with *Meal Powder* to fire the Fuze. This done, the Cylinder and *Grenado* shall be well bound together with strong Iron Wyre. In short,

short, it shall be put into the *Cannon* with the flat End of the Cylinder towards the *Powder*.

S O R T IV.

Fig. 125. In *Fig. 125* you have a fourth Sort of the same *Grenado's*, where the Letter D points out the *Grenado* itself. C is a Wooden Cylinder of the same Dimensions with the Third above; and has in the same manner a Concavity to receive one half of the *Grenado*. E is an Hole bored through the middle of the Cylinder which corresponds with the Fuze of the *Grenado*, and which shall be filled with *Meal Powder*. B is a Paper Cartridge fixed to the Wooden Cylinder, and covered at Top with Paper or Wood. This Cartridge holds the Requifite of *Powder*, which is necessary to diflodge the *Grenado*, as may be feen by A in the same *Figure*.

This does not differ much from the other fort we have already spoken of, and is the same which is represented in the *Cannon* in *Fig. 127*, except that this last does not appear with its Paper Cartridge; which must be formed upon a Wooden *Rowler* or *Former* after the same manner as the Cafes of *Rockets*. This is filled with *Corn Powder* as in the foregoing Cafe, and as it appears in the *Figure*. These two Sorts require to be charged with great Diligence and Expedition; and particular Care must be taken that the *Powder* is not too strong, for fear they should be damaged, from whence unhappy Accidents may ensue.

S O R T V.

This Way of shooting *Grenado's* from Pieces of *Cannon*, was not only designed for projecting one at a time (as may be imagined by what we have hitherto said) but likewise for throwing several small *Hand-Grenado's* at once into the Enemy's Camp, or amongst the Battalions which are drawn up in Day of Battel. This you may easily do, if you shut them up in hollow Wooden Boxes or Cartouches, such as you see in *Fig. 126*. *Fig. 126*. In the first place, the Bottom of the Cartouch, A, shall be twice as thick as the Sides, and shall be re-inforced with an Iron Plate, and wrapped round by a strong Paper Cartridge; or else you may tye a little Canvas Bag full of *Corn Powder* round it, as you see in D. The Fuze C shall be either of Wood or Iron, and filled with a *slow Composition*, by which the *Fire* is conveyed to the *Grenado's* as soon as the Box falls amongst the Enemy.

S O R T VI.

We may shoot *Grenado's* from *Cannon* without any of the abovementioned Additions to them; but they must in this Cafe be thicker at Bottom

tom than in the rest of their Circumference, as may be seen in *Fig. 128.* Fig. 128. These shall have Iron Fuzes which shall not in the least degree surmount or rise above the Convexity of the *Grenado*, and the lower Ends of them shall be received or let into the Bottom of the *Grenado's*, as may be seen by Letter A in the same *Figure*. This Fuze (which shall be filled with a *slow Composition*;) must be of the same Dimensions as we have ordered for the other Sorts of Fuzes; B shews you a Profil of it. The Bottom of this *Grenado* shall be turned inwards, or towards the *Powder* in the *Gun*, and consequently its Fuze must be directed outwards towards the Muzzle of it. Though the *Grenado* be fixed in this Posture, you need not fear its being fired before it gets out of the Piece; for being agitated by the Flash of the *Powder*, it must in its Excursion through the Chase of the *Gun* be turned and whirled round several times before it can reach the Muzzle; therefore it will be impossible for it to miss taking Fire from the Flash, which wraps itself all round it by turns.

S O R T VII.

Not long since; in the Reign of *Uladislaus IV.* King of *Poland* and *Sweden*, His Majesty's Engineer Major, *Frederick Getkant*, (who for his universal Knowledge in the *Sciences* and great Skill in all the Branches of *Mechanics*, deserves to be called a second *Archimedes* of our Country) contrived a most certain and infallible Way, for projecting *Grenado's* from great *Guns*; to which purpose he cast a Piece of *Cannon*, which as to Length is not very different from an old sort of *Gun* which the *Italians* at this Day call *Canone petriero incamerato*: But it differs greatly from this in its Chamber, which is so proportioned as exactly to contain the proper Requisite of *Powder*. It has moreover two Touch-holes, which terminate in the Vent of the Piece; one of which descends obliquely into the Chamber where the *Powder* is, and the other perpendicularly upon the *Grenado*, by which the *Fire* is conveyed to light a kind of *Quick Match* with which the *Grenado* and its Fuze are coated all round; to the end that whilst the *Powder* is taking *Fire*, the *Grenado* may be in a Readiness to depart, and only wait for the Motion which is to be given by the Flash of the *Gun*. I have taken the Trouble of giving you a Profil of this *Gun* with its *Grenado* lodged in it, as may be seen in *Fig. 129.* Fig. 129. As to the particular Proportions of the several Members of this *Cannon*, I shall refer speaking of them to the *First Book* of the *Second Part* of our *Artillery*, where I shall descant upon them at large, according to the best Information I could get from that celebrated Master of the *Military Arts and Sciences*.

COROLLARY I.

Grenado's of all sorts may be applied to very various Uses in the Conduct of War; many of which we shall specify in the subsequent Chapters. But if you attentively consider that *Grenado* represented under Number 118, by the Letter E, you will find it none of the most despicable. It is first shut up in two parallelopiped Timbers, which are securely bolted and forelocked together so as to keep the *Grenado* fixed and immoveable: It is then fired and thrown down from some Eminence, amongst the Enemy, where it does most horrid Execution by the Splinters of the Wood about it, and its own Iron Splinters.

COROLLARY II.

In order to shoot *Grenado's* from Cannon, the Requisite of Powder shall never exceed $\frac{1}{2}$ of the Weight of the *Grenado* and all its Furniture, without which it cannot be conveniently projected.

COROLLARY III.

We have observed that *Grenado's* of every sort of Construction, being fallen upon any Plane, do (by an inconceivable Mystery of Nature, and some secret Cause not hitherto traced out by the Wit of Man) burst and fly to pieces in an Angle of 45 Degrees. Whosoever keeps in mind this Remark, and the wholesome Advice I now give him, may avoid the Danger of all sorts of *Grenado's*, and make a Jest of them though they be pretty near, if before they burst he has time to lay himself flat on the same Plane which they fall upon: This I would have no Body forget, when they happen to be in such a Situation as not only to be oblig'd to see them, but also to take a Share of them.

COROLLARY IV.

Those who are curious to know the great Things that have been performed by *Grenado's* in the several Wars, since their Invention, may turn over the Commentaries of the Historians who have in our Age recorded the Remarkable Transactions in the *Low-Countries*. Those Gentlemen will tell you (without my giving myself the Trouble of doing it) that amongst innumerable Means for expediting the Sieges and Surrenders of Places, and which contributed the most to the Progress of the Arms on each side, the vast Expences of which were almost unequal to the entire Revenues of several *European* Kings and Princes; I say, they will tell you that *Grenado's* were always the chief and the first Thing they had recourse to; which by the Industry of skilful *Pyrobalists*

lifts (in which, thank God, the *Low-Countries* are so fertile, as to afford to spare them to their Neighbours) were showered into besieged Places, and into the Enemy's Trenches, which such prodigious Devastation as cannot be reflected upon without Horror. How many *Veterans*, and old Citizens have we living at this day, who count themselves happy, and glory in having been present at those destructive Scenes? and seem to despise such as have never been, like them, at the Siege of a *Breda*, a *Boisleduc*, an *Ostend*, or a *Maestricht*, &c. which they look back upon, and describe to you with a secret Satisfaction of having escaped the Danger?

All these will concur with me, and confess, that the *Grenado's* which were sent amongst them from the Enemy's Lines of Approach, not only struck them with Dread, but also urged them to a speedier Capitulation than they design'd. And how was it possible for them to hold out any great length of Time? For according to the Idea I have formed to myself, they could see nothing on all Sides but dead Bodies stretched out; People buried under Rubbish; or else frightful Wounds; Arms, Legs and Heads mashed to pieces; together with the melancholy Ruins of once-magnificent Edifices, promiscuously blended in one common Destruction with the obscurest private Dwellings; and all owing to *Grenado's*. In short, we may believe that the Calamity was inexpressible, and that the Inhabitants could find no Place of Refuge where they could be in Safety.

But to corroborate what I have said, and to shew that I do not desire you to pin your Faith upon my Words only, I shall recur to the Testimony of two famous Authors who were present at the Siege of *Boisleduc* and *Breda*, and who were careful Observers of every remarkable Occurrence that happened. First then, *Daniel Heinsius*, in his History of the Siege of *Boisleduc*, speaks of *Grenado's* in these Terms. *The Enemy were not behind-hand with us in any respect, but defended themselves with such Bravery, that we could not gain an Inch of Ground upon them, but by very great Compulsion, or by their own Will: During this, nothing was to be seen but Balls of Fire* (by which he means *Grenado's*) *which were sometimes thrown by Hand, and sometimes sung through the Air by Machines, and conveyed Fire and Dread wherever they fell; nothing more cruel or frightful was ever seen; and no Word can be more expressive of their sad Effects, than Death itself: For whenever they fell upon the Ramparts or Houses, the poor Inhabitants were put into the utmost Consternation; And almost as often as our Engineers threw any amongst them, we presently saw Household-goods, Furniture, and Cloaths blown up into the Air; and it is not to be doubted but in a long course of Time, and by frequent Repetitions, some of them fell into their Arsenals and Magazines. As for those which the Enemy threw amongst us in our Entrenchments and Works, we had Opportunities of avoiding them.*

Boxhornius says something to this purpose concerning *Grenado's*, in his History of the Siege of *Breda*; namely: That *three Houfes were demolished by one of thofe Fire-Balls which were called Bombs. Grenado's did not fall fhort of them in Execution, from the Danger of which there was no escaping but by a Miracle.*

But I fhall pafs over a great number of *Historians*, whofe *Works* are filled with *Narratives* of this kind; and fhall only appeal to the *Perfidious Mufcovites* who are ftill living, and alfo to the multitude of *Auxiliaries* that joined them, when they invested and took the *Fortrefs of Smolensko* in *white Ruffia*, (which was afterwards retaken from them in the Year 1634) to tell us what they know of the *fhange Havock* made by the *Grenado's*, which the *Lithuanians* threw into their *Camp*, inceffantly for three Months together. But if they fhould be filent upon this Matter, our mighty *Prowefs* has ftunned them in fuch a manner (if I may fo exprefs myfelf) that they will have no more Heart to make head againft our *Victorious Arms* for the future, than if they had been thunderftruck. It will be enough if I inform the *World* that our *Pyrobolic Thunder* drove them to fuch *Extremities*, that thofe *Barbarians* could find no *Safety* even in the *Bowels of the Earth*; and that though they took *Refuge* in the moft profound *Caverns*, yet our *Grenado's* found them out, and did their *bufinefs*. In fhort; perceiving themfelves overwhelmed day after day with *fhresh Difafters*, and being quite difpirited, they were obliged to throw themfelves, and all their *Warlike Apparel and Habiliaments*, at the *Feet of our Invincible and Auguft King the Great Uladiflaus IV*, in the moft *fhuppliant Pofture*, begging *Life and Liberty*, that they might have the *Satisfaction* of ending their *Days* in their *Native Country*, rather than be *Food for Wolves and Ravens* in a *fhrange Land*.

But let us now, on the other hand, confeffs that there is nothing to prevent the *Befieged* from demolifhing the *Befiegers Works*, by *Grenado's*, or from putting them into the utmoft *Confufion and Diforder*; (though indeed not to compare, with the *Calamities* they caufe in inclofed *Places*) to confirm which, I fhall give you no other *Example* than the famous *Siege of Ofend*, which was as *Memorable* on the *fhore of its Duration*, as on account of the many *gallant Perfons* who there gave the moft *confpicuous Proofs* of the moft *Heroic Bravery*. The famous *Annalift Paulus Piafcius*, *Bifhop of Premiflaw*, fpeaks thus of it in the year 1601. *They began with throwing a vafh many Balls of Fire, by the Affiftance of Machines; fo that the Befieged had no where to fhelter themfelves; That there was nothing to be feen but Artificial Thunder and Lightning, flying backwards and forwards in the Air; and That to his Knowledge there were rather more than 50000 thrown into the Town in one Month's time, and 20000 from out of it.*

But to what *purpofe* fhould I dwell longer upon this *Subject*, fince we have ftill *fhresh* in our *Minds*, *Instances of the famous Sieges* carried

on lately in *Spain, France, Italy, Germany, Poland,* and the *Low-Countries,* (which have always been the grand Theater of War, and principal School of *Mars*;) not to mention particularly the vast Numbers of Towns, that have been invested over all *Europe*; and have by rueful Experience found (as is also allowed by the most expert Judges in *Military Affairs*) that *Grenado's* are the Bane of the Besieged, the Ruin of Cities, and commonly the Death of most of the Besiegers; notwithstanding that it is certainly easier for the latter to escape the Danger of them, than the former.

C H A P. V.

Of † Fire-Balls, which the Latins call Globi Incendiarii or Igniti, the Italians Palle di Fuoco, the Germans Ernst and Fewer Kugelen, the French Boulet a Feu, the Flemings Vyer Ballen, and the Poles Ogniste Kule.

SINCE *Fire-Balls* are of a much elder Date than our *Grenado's*, it may be wondered why they did not take place of them, as being the first in the natural Order of Things: But the fertile Invention of our Modern *Pyrobolists* suggesting new Thoughts to them every Day, towards the Improvement of the Old, or Contrivance of New *Machines*, and all New Inventions in every *Art* being commonly established in Prejudice of the Old, as if for being New, they are of more intrinsick Worth, and more perfect than the former; *Fire-Balls* seem to have given up their Place, and to have yielded to *Grenado's*; and are accordingly grown almost out of Use. However, the frequent Services they have done rendering it indisputable, that they are in some sort useful upon Warlike Occasions; I shall give you the Method of their Construction, and shew you their several Forms and Shapes with us; and those also which they had formerly; together with Representations of them drawn in the most curious Manner I am able. But before we enter upon a particular Description of them, let us examine a little into their Form, which will facilitate the making of them.

The Form then of *Fire-Balls* may be very various, but the most common is that of a Spheroid, or a Sphere: And in Consideration that they must be made of coarse Cotton Cloth, or any Cloth more substantial and stronger, if any such is to be had; you must, to expedite your Work, have *Patterns* (which the *Germans* call *Muster*) by which to cut out your Cloth, which shall be afterwards sewed up in Oval Bags as a

† Our Carcasses are an Improvement upon these.

Spheroid, or in Round ones as a Sphere; which must be afterwards filled with combustible Matter, and several *Pyrobolical Compositions*.

The Patterns for Spheroidal Bags may be prepared after several Ways, five of which I shall here communicate to you; and First, Take the Diameter of the *Mortar*, from whence you are to project your *Fire-Ball*, and setting it off upon some Plane, divide it into 4 equal Parts, as Fig. 130. may be seen in Fig. 130. Then fixing one Foot of your Compasses at the Extremity of the Diameter (*viz.*) at B; extend the other to $\frac{1}{2}$ of the said Diameter (*viz.*) to C; and with that opening describe an Arch of a Circle D C E; then shifting your Compasses to the Point C, with the other describe another Arch of a Circle D B E, intersecting the First in the Points D and E; by this means you will have a longish *Figure* comprehended between the two equal Arches D C E B, which will be the Pattern for your *Fire-Ball*. This done, cut out four Pieces of strong Cloth, by the said Pattern, and sew them well together, and you will have a Bag in the perfect Form of a Spheroid, after it is filled with an *Artificial Composition*.

The Second Way of fashioning Patterns for *Fire-Balls* is thus: Divide (as we ordered above) the Diameter of the *Mortar* into 4 equal Parts, as may be seen in Fig. 131. Then extending the Diameter A B as far as C, in such a Manner that A C may be double of the Diameter A B, you shall divide the Additional Line B C into 4 equal Parts, so that the whole Line A C may be divided into 8 equal Parts: Take then $\frac{1}{2}$ with the Compass, and from the Point A which is one of the Extremities of the Line A C, describe an Arch of a Circle towards C; and then reciprocally from C describe another Arch intersecting the First in the Points E and D; and thus you will have another Pattern which will be a sixth Part of a Spheroidal Bag. Therefore by this Pattern shall you cut out six pieces of Cloth, and sew them strongly together to make your Bag.

Fig. 132. Under Number 132 you have three different Ways of making these Patterns; the First of which (*viz.*) A, is done by assuming the Diameter of the Circle for the *Radius* of the Arcs. The Second (*viz.*) B, by the mutual Interfection of two Circles, whose Diameters are equal to the Diameter of the *Mortar*. In short, the Third is inscribed within the said Circles. These three different Methods give Patterns for three different Spheroidal Bags, when three Pieces only are sewed together.

The common Way of forming Patterns for perfectly Round Bags, is thus: The Diameter of the *Mortar* being bisected into two equal Parts, describe a compleat Circle round it, which you shall quadrisect into four Quadrants, each of which shall be trisected into three equal Arches. This done, produce a Right Line; upon which you shall set off 19 of the Subdivisions of the Quadrants, as may be seen in Fig. 133 under the Letter A; where A B is the Diameter of the Circle, and B C the Right Line divided into 19 of the abovementioned Parts, each equal to $\frac{1}{3}$ of a Quadrant

Quadrant of the aforeſaid Circle. Now if you fix one Foot of your Compaſſes at the Extremity B, and extending it to the Eleventh Di- viſion deſcribe an Arch of a Circle; and if you reciprocally deſcribe another Arch of a Circle interſecting the Firſt in the Points E and D, you will have a Pattern for Round Bags: Therefore cutting twelve Pieces of new Stuff by this Pattern, and ſewing them together, you will have a Spherical Bag.

In the ſame *Figure* you have another Method of doing this, under the Letter B; which I have taken from Chap. I. of Book III. of *Die- gus Ufanus's Artillery*; “ Having taken the Diameter of the *Mortar*, “ inſcribe it in a Circle, which being divided into Quadrants, by ano- “ ther Diameter interſecting the firſt at Right Angles through the Cen- “ ter of it; you ſhall from the Extremities of the Chord or Subtenſe of “ any one of thoſe Quadrants, deſcribe two Arches interſecting each “ other; and from the Point of their Interſection deſcribe a Third Arch; “ ſo that they may compoſe an *Æquilateral Spherical Triangle*. This “ done, cut out 8 Pieces of Cloth by this Pattern, and ſew them neat- “ ly together, and you will have a Spherical Bag.” If you would now ſee the manner of ſewing theſe Bags, caſt your Eye upon *Figures* 134 Fig. 134 and 135. and 135.

Compoſitions for Fire-Balls.

Notwithſtanding that all the *Compoſitions* we have already given for *Water-Globes*, might ſerve for *Fire-Balls*; yet becauſe theſe require to have them a little more violent, and are to dart forth a very long Flame, and vomit out a great Quantity of large *Sparks*, to the end that ſuch as would endeavour to ſtifle them may not be able to approach near them; I ſhall touch upon an infallible Way of preparing them, and alſo of try- ing them after they are made.

C O M P O S I T I O N I.

Take of *Meal Powder* 10 lb; of *Salt-peter* 2 lb; of *Sulphur* one lb; and of *Colophone* one lb.

C O M P O S I T I O N II.

Take of *Meal Powder* 6 lb; of *Salt-peter* 4 lb; of *Sulphur* 2 lb; of coarſe Powder of *Glaſs* one lb; of *Crude Antimony* lb ſs; of *Campfire* lb ſs; of *Sal Armoniac* one lb; and of common *Salt* ʒ iiij.

C O M P O S I T I O N III.

Take of *Meal Powder* 48 lb; of *Salt-peter* 32 lb; of *Sulphur* 16 lb; of *Colophone* 4 lb; of Filings of *Iron* or *Hammer-flaw* 2 lb; of the Saw-
duſt

dust of *Fir* or *Pine* boiled in a *Saltpetrous Water* and then dried, 2 lb; and of *Birch Coal* one lb.

The *Powder* shall be first reduced to a very fine Meal for all these *Compositions*, and passed through a very fine Hair Searce: As for the other *Ingredients*, they shall be but indifferently pulverized; because if they were to be reduced to a very fine Meal, the *Composition* would emit but very small weak Sparks, and those not to any great Length. Or on the contrary, by being in pretty large Lumps, one *Ingredient* could not well incorporate with the rest, but would all burn independantly of each other, and lose the *Fire* before it could have time to inflame the Whole: You must therefore be very careful in preparing these *Compositions*, the Goodness of which may be tried as follows.

Take a wooden Fuze, or a Paper Cafe, no matter which, of the Height of half a Palm, and the Orifice of it the Breath of half a Finger only: Fill it with your *Composition*, and nicely observe the following *Prognostics*.

If the Flame rises to the Height of a Palm, that is, to twice the Height of the Fuze which contains it.

If it throws out a good quantity of *Sparks* on all sides, with a pretty great Noise and an acute Crackling; which falling upon the Head of a Drum have Strength enough to break through it, or at least Heat enough to burn it.

If, in short, it burns during the Time you can rehearse the *Apostles Creed*.

I say, if you observe all these Indications, you may conclude that your *Composition* is in very good Temper; therefore you may not only use it for your *Fire-Balls*, but also for your *Fire-Lances*, *Clubs*, *Garlands*, *Crowns*, *Darts*, *Fire-Hoops*, and the rest of your *Pyrological Machines*, which we shall speak so amply of in the Sequel. But if you observe your *Composition* to be either a little too weak, or too strong, you may easily make amends for it by adding *Quick* or *Slow Matter* to it. You will not do amiss, if you sprinkle your *Composition* over with a little of some sort of Oil, that the *Ingredients* may unite the closer, and that if your *Ball* happens to fall into Water, or any damp Place, it may be enabled thereby to maintain its Combustion with the greater Obstinacy.

Having thus given you the proper *Compositions* for *Fire-Balls*, I can do no less than proceed to instruct you in the Preparation of the several Species of them, and shew you how you are to charge them.

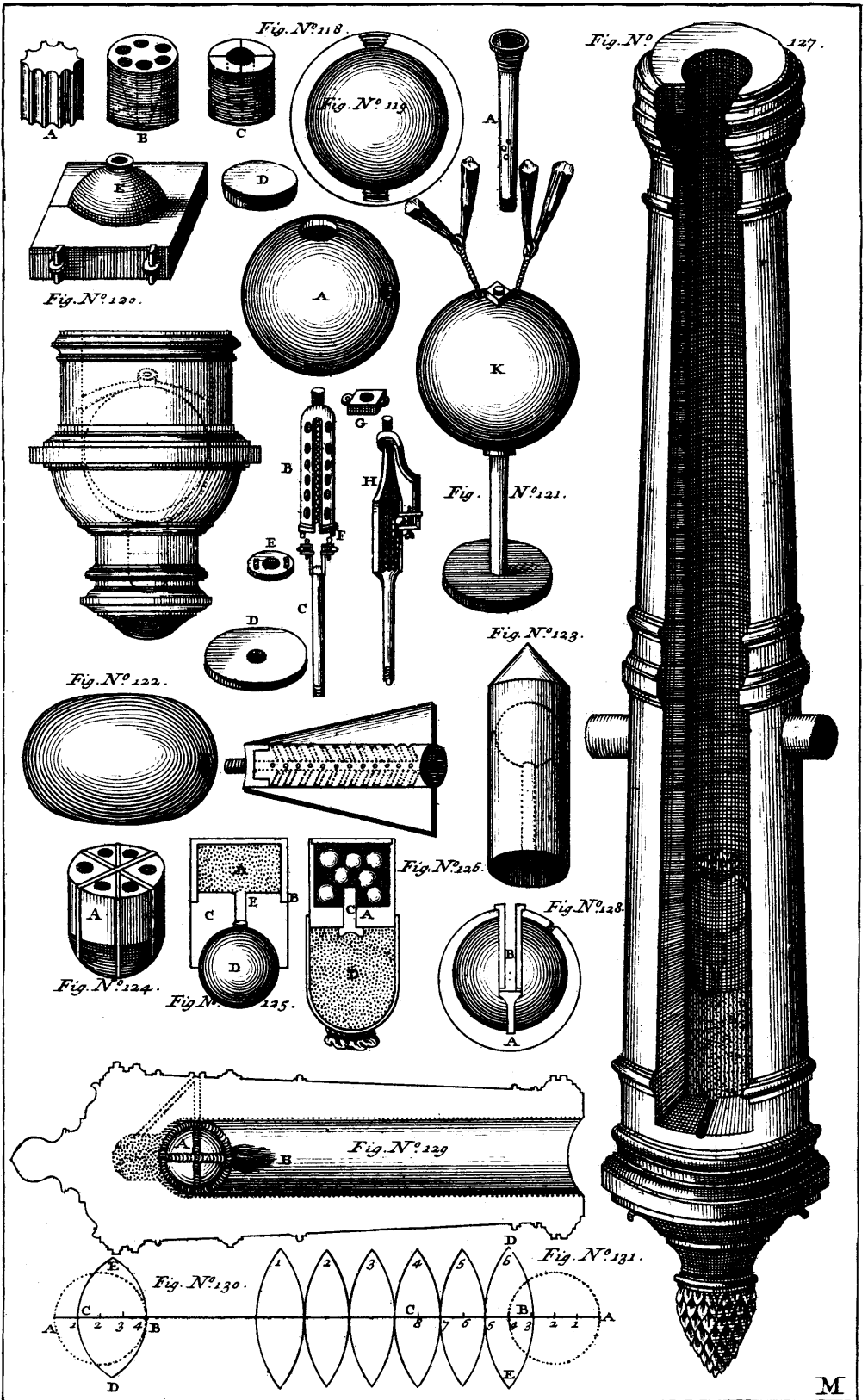

M

OF FIRE-BALLS.

S O R T I.

For this, you shall first make a longish Bag, according to the Order and Method already laid down, and fill it up to the Brim with one of the above *Compositions*, pressing and shaking it down as much as possible, 'till it is almost as hard as a Stone. Then stopping the Orifice of it with a Wooden Stopple D; take two Iron Rings, of which that which is to be uppermost upon the *Ball* (you have it represented in B, *Fig.* 136) *Fig.* 136. shall be $\frac{1}{2}$ of the Diameter of it; and that which is to be beneath shall be but $\frac{1}{4}$ only: You have this in Letter A.

But I must beg your favourable Acceptance of what I have here taken from *Brecheletius's Pyrotechnics*, relating to this matter. "He says then, that for *Balls* of 100 lb, the upper Ring shall be $3\frac{1}{2}$ *Unciæ* or Inches, and the Lower one 3 *Unciæ* only. For *Balls* of 75 lb, the Upper Ring shall be 3 *Unciæ*, and the Lower one $2\frac{1}{2}$ *Unciæ*. For *Balls* of 50 lb, the Upper Ring shall be $2\frac{1}{2}$ *Unciæ*, but the Lower one 2 *Unciæ* only. For *Balls* of 25 lb, the Upper Ring shall be $1\frac{1}{2}$ *Unciæ*, but the Lower one $1\frac{1}{4}$ *Unciæ* only. For *Balls* which exceed 100 lb, as for Example, 125, or 150, or more; the Rings shall be increased half an *Uncia* for every fifteenth Pound. As for *Balls* between the Fifteenths, their Rings shall always observe a *Medium*, between the next greatest and the next least; in short, they shall be proportioned as shall be judged most convenient." As much may be said of their Thickness, for according to the Size of your *Balls* must you make your Rings more or less substantial, in which you must be guided by your Eye. Upon the whole, you must take Notice when we mention the Weight of a *Fire-Ball*, that we mean, if the Diameter of the *Mortar* from whence it is to be projected was to be applied to that Side of the *Calibre Scale* which is calculated for *Stone Bullets*, it would point out such a Number of Pounds. This you must keep in mind, throughout the Remainder of this *Discourse*.

Suppose now you have two Rings of proper Dimensions, one for the Top and the other for the Bottom of your *Ball*: Take a strong Cord or Line (whose Thickness must not exceed that of the Rings) of the Length of 8 or 9 Yards, more or less according to the Size of your *Ball*, and tying one End of it to either of the Rings, and passing the other through a Needle (as may be seen in the *Figure*) lace your *Ball* tightly round with it, observing to do it in so neat a manner, that your Lacing may appear like little Ladders of Cord, or (to give you a better Comparison) like the imaginary Meridians and Parallels drawn upon a *Terrestrial Globe*; cast your Eye upon *Figure* 137, where you will see it *Fig.* 137. just as I have described it.

Now to ease you of some of the Trouble you might be at in Lacing or Cording these *Balls*, I have given you the Construction of a Wooden Stool in *Fig. 147*, upon which if you fix your *Ball* between the three Iron Spikes which you see bent outwards, you may conveniently perform your Work. If you should sometimes happen, through too much Haste, or for want of being used to this Work, to make any Slips or Mistakes in your Knots, &c. you may undo them with the *Marline-Spikes*, which you see under *Number 150*, distinguished by C and D, and E: A and B are two *Copper Needles*.

Having thus laced or corded your *Ball* after the manner we have ordered, you will have nothing to do, but to thrust *Iron Crackers* into the Body of it, which you may easily do by the help of that little Convenience like a Pole-Ax which you see in *Fig. 149*, or such a Borer as you see in *Fig. 146*. But before I proceed farther, I must say something concerning the Proportions of these *Crackers*, how they are to be fixed, and what Order is to be observed in charging them; because we shall, for the future, make great and frequent Use of them, as very necessary Adjuncts to the several *Balls* we shall prepare.

Pyrobolists usually make three Sorts of *Copper* or *Iron Crackers*, for their *Fire-Balls*, and each of a different Length; to which they are induced by sufficient Reasons and continual Experience, which (according to the common Saying) is the *Mother of all Things*. The first and longest of the three you have in *Fig. 137*, where it is distinguished by the Letter A: B is the middling or mean one; and C is the least. We shall give Reasons for this Inequality hereafter; but as to their Length in general, you must observe the following *Rules*.

You shall divide the Diameter of a *Fire-Ball* into 4 equal Parts, one of which will exactly give you the first *Cracker* without its Point. The Second shall be $\frac{2}{3}$ of the Length of the First, and the Third $\frac{1}{3}$; or if you would rather choose to proportion them by the Diameters of *Bullets*, you shall proceed as follows.

For *Centenary Fire-Balls*, by which we mean such whose Diameters are equal to that of a *Stone Bullet* weighing 100 lb, the *Crackers* shall be made of *Iron* or *Copper Plates* turned into Tubes, which shall be soldered both without and within if possible, and their Orifices shall be reinforced with a Ring of the same Metals. The Diameter of their Orifices shall be equal to that of an *Ounce* of Lead; and their Length shall be 6 of the same Orifices; I here mean the longest *Crackers* only; for the middling shall be but $5\frac{1}{2}$ Diameters; and the least but 5. For *Fire-Balls* which fall short of this Weight, the Diameters of the *Leaden Bullets* shall be insensibly diminished, and the Lengths of the *Crackers* shall be proportioned, as I said just now: You must only observe here, that the *Leaden Bullets* which are to determine the Diameters and Lengths of the *Crackers* for *Fire-Balls* of 25 lb, shall weigh half an *Ounce*: But for the rest down from 20 to 15 or 10 lb (which are

are the least that ought to be made) the *Leaden Bullets* shall weigh at least two *Drams*: The Lengths of the *Crackers* must be as I have said above.

Your *Crackers* being thus ordered, take the little Pole-Ax, or an Iron Spike, and driving it with a Wooden Mallet, which you have in *Figure 148*, into the Spaces between your Cording, thrust your *Crackers* into Fig. 148. those Holes, in such Order that the longest of them may be in the middle part of the *Ball*, and beneath them towards the Bottom you must drive in your lesser; and in short, all round the *Vent* and towards the Top you shall drive in your least, so that the Ends of them may be turned downwards towards those of the longest. However, you must be cautious how you put them too near the *Vent*, for fear of their going off too soon. You shall likewise take Care that they be not all in one Position, but that they be diversly disposed, in such manner that their Ends may be turned alternately upwards and downwards to the Right and to the Left, that they may not go off many at a time, but by degrees one after another.

If it happens that your *Fire-Ball* is so solidly or closely filled, as to refuse Reception to so great a Number of *Crackers*, as must of necessity be thrust into it, you shall (after having driven in the Spike of your little Pole-Ax) compleat the Hole with the *Borer 146*, or some Tool like it, with which you may scoop out so much *Composition* as will make room for your *Crackers*.

When these *Crackers* are driven into the Body of your *Ball*, you shall fill them with good *Powder* to the Height of 3 Diameters of their Orifices, and over that a *Leaden Bullet*, and then a good Wadd of Paper or Tow; and let them be closely stopped up.

To conclude; the *Vent* of your *Ball* shall be made within the Upper Ring, by cutting the Cloth crosswise, or like a Star; but you shall not have one only; for you shall make three others in a Triangular Position, and at the distance of 3 or 4 Inches from that in the middle, which will be of great Service, and make your *Fire-Ball* as effectual as you could wish. These Holes are made to facilitate the Accension of the *Composition*, and to prevent its Fire from being easily suffocated by the Enemy with raw Hides, wet Bags or Matresses, &c. and to assist it if it should fall into soft Earth, or Mudd, Ashes or Green Turf.

Being thus adjusted, it is necessary to dip it into a certain *Composition*, which the *German Pyrobolists* improperly call *Tauff*, and *Ernstkugel Tauffen*, which signifies to baptize a *Fire-Ball*; this is to be done as follows.

Get first an Iron or Wooden Ring equal to the Bore of the *Mortar* you would use, the *Figure* of which you have in 145 under Letter A: Fig. 145. In the same *Figure* you also have a Wooden Board or Iron Plate, bored through with Holes of various Sizes, as in Letter B: Either of these Instruments are very convenient for measuring the Circumference of your *Ball*,

Ball, that you may not inadvertently make it unfit for the *Calibre* of the *Mortar*, in lacing it and in coating it with the following Mixture.

Take then 4 Parts of *Ship Pitch*, 2 Parts of *Colophone*, 1 Part of *Linseed* or *Turpentine Oil*, and melt and mix them well together in any large Brafs Boiler, or glazed Earthen Pot; and taking this liquid Mixture from the Fire, throw as much *Meal Powder* into it as may be sufficient to thicken it: Then holding your *Ball* by a String dip it into this Stuff up to the Vent, (which shall be previously and tightly stopped up) and afterwards coat it round with Tow, that its Convexity may be perfectly smooth, and the Knots entirely hid.

Whilst you are dipping it, you shall from time to time measure it by the above Contrivance, and continue the Immersion of it till it is exactly of the due *Calibre* you want. You have this *Fire-Ball* most

Fig. 137. curiously represented in *Fig. 137*: But we have said enough of it, let us therefore proceed to the rest.

S O R T II.

In the Preparation of this, you must first have a Bag, (no matter whether it be Spherical or Spheroidal;) in the Bottom of which you shall fix 6, 8, or more *Hand-Grenado's* with very short Fuzes, which Fig. 138. shall be turned downwards; (as you may perceive in Letter C *Fig. 138*,) these *Grenado's* shall be afterwards buried under a proper *Composition*, with which the Remainder of your *Fire-Ball* shall be quite filled up: You shall then have two Iron Basons like Scales, the Rims of which shall be bored through with little Holes. That which you design to be uppermost, shall be open at Top like a Milk-strainer; these are distinguished by A and B. To the opening of the upper Bason you shall solder an Iron Fuze, which must be filled with one of the *Compositions* we have already given for Fuzes,

This done; clap your Basons upon the Top and Bottom of your *Ball*, and lace them tightly on, through the aforesaid Holes in the Rims of them; and dip and coat this *Ball* as you did the Former. You are to add *Iron Crackers* to this, if you will; but you must take care that they do not interfere with the *Grenado's*.

S O R T III.

Take a round Bag, which being filled with *Composition* may form a Fig. 139. Spherical *Ball*, such as you see in *Fig. 139*, 140, and 144, First fill
140. it with *Corn-Powder* to $\frac{1}{2}$ of it's Height, and let it be interspersed with
and 144. *Leaden Bullets*, bits of Iron, pieces of Flint, and such like Things. The rest of this *Ball* shall be filled quite up with one of the *Compositions* already given for *Fire-Balls*, and shall be adjusted on the Outside like the last. You have this, in *Fig. 140*.

In

In short; take a good quantity of *Leaden Bullets* of an *Ounce*, or half an *Ounce* weight, with each a little *Iron Needle* or *Point* belonging to it. Arm all the *Interstices* of your *Lacing* with these, by driving them into the *Composition*; and coat this *Ball* as before, that neither the *Bullets* nor *Lacing* may appear. The *Fuze* for this (which you see in A) shall be filled as usual. Fig. 139.

S O R T IV.

The *Ball* I am now going to present you with, is most horrible in its *Effects*; which are the more frightful, because the *Treachery* of its *Construction* can be no way suspected; For what can be more surprising to the *Poor People*, amidst whom such a *Ball* is sent, (who taking it to be one of the ordinary *Sort*, and accordingly use their utmost *Endeavours* to stifle it) I say, what can be more surprising to them, than to be on a sudden most cruelly butchered by it: And what is farther extraordinary, it does not perform its *Execution* all at once, but by a *Repetition* of 3 or 4 *Times*, which still makes it the more dreadful. If you would learn the *Construction* of this, you must mind the following *Directions*.

Take the *Diameter* of the *Mortar* you intend to use, and divide it into 5 *Parts* in a *Stereometrical Proportion*. Now though I apprehend I have fully instructed you in this *Operation* in our *First Book*; yet in consideration of this wonderful *Invention*, I shall subjoin the following *Method*.

Look into the *Table of Cube Roots* (which you have in *Chap. 1.* of *Book 1.*) for the *Number* of equal *Parts*, contained in the *Fifth Root*, and you will find it to be 171: Divide then the *Diameter* of your *Mortar* into 171 equal *Parts*. And since in the said *Table* the *First Root* is composed of 100 *Parts*, you shall take $\frac{47}{171}$ of the whole *Diameter* abovementioned, for the *First Portion*; $\frac{14}{171}$ for the *Second*; $\frac{17}{171}$ for the *Third*, and $\frac{13}{171}$ for the *Fourth*, which last must be added to the *Fifth*, for *Reasons* hereafter given; in short, I need not tell you that the *Fifth* will be 171 *Parts*.

These *Cubical Portions* of your *Diameter* being found, you must inscribe the *First*, *Second*, *Third*, and *Fifth*, in any *Circular Figure*, as if they were *Original*, or *Primitive Diameters* (as we shewed in the same *Chapter*.) These *Circumferences* will serve you for forming *Patterns* to cut out your *Bags* by.

I have given you a *Fire-Ball* of this *Construction* in *Fig. 141*, which Fig. 141. indeed is *Oval*, though I must own I like the *Round* best. The greatest (*viz.*) A, which contains 3 smaller, has its least *Diameter*, or (or if you will) its *Breadth*, equal to the *Fifth Portion*, or (to speak more intelligibly) equal to the *Calibre* of the *Mortar* it is to be projected from: The like *Diameter* of B, is the *Third Cubical Division*;

T r r and

and the Diameter of D, is the First or Least. All these Diameters are mean Proportionals betwixt two Extremes. The order they observe, both as to Capacity and Bulk is thus: If the First or Least *Ball*, D, contains one lb of *Composition*; the Second C will contain twice as much; and the Third will hold 3 lb. Thus these three, contained by and in each other, need only have 1 lb of *Powder* for every one in particular.

In short, the Fourth and Last would be sufficiently capacious to contain 5 lb of *Composition*; but as the Third is to be included in it, which on the other hand holds the two which are less than itself, it will require but two Pounds of *Composition* to fill it quite up. The Reason why this Last *Shell* or *Ball* is allowed a greater quantity of *Composition* than the three others; is, that the three Lesser, upon the bursting of the Greater, may suddenly take fire one after another; so as to give the Enemy no Opportunity of suppressing or extinguishing them, and consequently they should have but very short Fuzes. For as the whole *Ball* (as compounded of all the rest) takes up some time in its Projection, and requires a few Moments before it breaks after it is fallen, it is proper to allow this Fifth *Shell* or *Bag* that Portion of *Composition* and Fuze which would have been taken up by the Fourth.

As to the Construction of these *Balls* thus contained in one another, I have told you above, almost as much as can be said of it. But I think I had as good repeat it over again.

The Least then shall be filled according to the Method prescribed for the foregoing: (*viz.*) You shall fill it to $\frac{2}{3}$ of its Height with the best *Corn Powder*, and the remaining Third with one of the above *Compositions*: It shall then be well corded, and armed with *Leaden Bullets*, and coated with Glue and Tow, instead of Pitch. When you put this First into the Second, it must have its Orifice exactly answering to the Orifice or Vent of the other. The Second shall be filled with *Corn Powder* to the Height of the First *Ball*; and the remaining Vacancy with the same *Composition*. This likewise shall be firmly laced; and between the Lacing it shall be armed with *Iron Crackers* loaded with *Powder* and *Ball*, so low as the *Composition* reaches; But Care must be taken that these *Crackers* be not so long as to incommode the included *Ball*: Beneath these upon the *Corn Powder* you shall add *Leaden Bullets*, and under them you shall stick in little *Iron Spikes* to fill up the Interstices of the Cording. In short, this *Ball* shall be coated with Glue and Tow like the foregoing. The Third shall be prepared exactly like these two. And finally, the Last and Greatest shall be ordered just like the three former; but it will bear to have its *Crackers* longer, and in greater Number. It shall also be armed with *Leaden Balls*, all over that Part of it which contains the *Corn Powder*. In short, you shall coat it in the same manner as we ordered for the
above

above Species of these *Balls*, and be (just like them) most exactly fitted to the Bore of the *Mortar*.

Observe here, that it will be proper for the three *Balls* contained in this last to have three *Vents* pretty near to each other, which shall be filled with *Meal Powder* to facilitate their Accension, and render it a difficult matter to suppress them.

S O R T V.

This *Fire-Ball* is most commonly shot from *Cannon*, and particularly when you would set Fire to the loftiest Edifices of a Town; or burn any Wooden Houses, particularly when they are only roofed with Shingle, or thatched with Straw or Reeds; which manner of Building is the most common throughout *Poland*, *Lituania*, *Russia*, *Sweden* and *Muscovy*. *Cornelius Nepos* tells us, in *Plin. Lib. XVI. Cap. X.* that besides several Towns in *Spain* and *France*, (witness *Cæsar*) even *Rome* itself was only covered with Oak Laths for the Space of 470 Years. Add to this the Testimony of *Vitruvius*, who confesses in *Lib. II. Cap. I.* that the Palace, or rather the Cabbin of *Romulus*, was only thatched with Straw, which in Commemoration of that first Founder of the *Roman Empire* was always kept whole and entire. This was the Magnificent Pile that *Virgil* speaks of *Æneid. VIII.* where he describes the Work on *Æneas's* Shield.

*In summo custos Tarpeia Manlius arcis
Stabat pro templo, & Capitolia celsa tenebat;
Romuleoque recens horrebat regia Culmo.*

In *English* thus :

High on a Rock Heroic *Manlius* stood ;
To guard the Temple and the Temple's God.
Then *Rome* was poor ; and there you might behold,
The *Palace* thatch'd with Straw, now roof'd with Gold. *Dryden.*

Ovid also gives us to understand that the Habitation of this First *Roman* was only thatched with Straw : I leave you to judge what sort of Dwellings the rest of the People had.

I say then, that it will be very proper to shoot *Fire-Balls* from *Cannon* at such kind of Edifices, except they are so low, or the *Ramparts* so high that they are hid from Sight, for in that Case it would be best to project them from *Mortars*.

Most of the Sieges which have been carried on in our Country, have furnished us with Examples, sufficient to evince the Utility of this Contrivance. Methinks I now see *Biall*, a little Town in *Severia*, not indifferently fortified or garrisoned, which was invested the same Year as the

the *Muscovites* were forced to deliver up themselves at *Smolensko*, by that Heroical and Magnanimous Prince *Christopher Radziwille* Palatine of *Wilna*, General of the Armies of the Great and Mighty Dutchy of *Lithuania*; who conducting that Siege like a brave Captain, and an excellent Politician as he was, caused great Numbers of *Fire-Balls* to be shot upon the slight Lodgments and Cabbins of the *Muscovites*, that were only thatched or covered with Shingle, which did them such Mischiefs as is not to be conceived, and all they could do, could not preserve their Town from the Flames. Thus those *Barbarians* found by Experience, that Art and Stratagem are always attended with better Success than blind Rage or inconsiderate Rashness.

I cannot pass over what *Justus Lipsius* relates in his *Polioreticon*; concerning the prodigious Devastation made by *Fire-Balls* in certain Places of *Muscovy* and *Livonia*, which were besieged and taken by *Stephen King of Poland*; he writes to this Effect: *This great King invented Fire-Balls which he threw into the Wooden Retrenchments of the Muscovites and Livonians: Upon which those Barbarians complained that the Laws of War were violated, and the Honour of Arms polluted, by such unfair and unprecedented Dealings: But our People laughed at them and their Remonstrances too, and rejoiced in their own Success.*

These *Fire-Balls* are sometimes used in Sea-Fights, to burn the Enemy's Sails and Rigging; in short, to destroy their Ships: But these should be armed beneath with a bearded Harpoon, to run into the Planks, and to make the Danger of them inevitable: Or that being fired at the Sails the Harpoon may go through them, and keep the *Ball* hanging in them: (But I am inclined to think that the Body of the *Ball* would be driven through the Sails; and that therefore it would be better to shoot *Fire-Darts* and *Arrows* at them from a *Cross-Bow*) I say, the Harpoon piercing through the Canvass, and the *Ball* being naturally urged to hang downwards, and the Beard of the Harpoon hindering it from falling down, the Sails cannot avoid taking Fire. All that can be done in such a Dilemma, is at once to clew up the Sails and strike the Yards, in order to extinguish the Fire upon the Ship's Deck; which must put the Enemy into unspeakable Confusion.

Fig. 142. The Fashion of this *Ball* is clearly expressed in *Fig. 142*. The Harpoon I have mentioned is under *A*. This must be ordered by the very same Rules as the rest we have described; *Crackers* loaded with *Leaden Bullets* would render it dangerous to approach it.

S O R T VI.

This last Sort of *Fire-Ball* bears some resemblance to that Old *Grenado*, the *Figure* of which you have in Number 115 in its outward Form; but I cannot say there is any great Likeness between them in their Effects. This *Ball* is grown antiquated and entirely disused, on the
score

score of its Form, which will not permit it to move freely through the Air; for we have found by Experience that those *Projectiles* which come the nearest to a Sphere meet with the least Resistance from that Element; therefore this, approaching nearly to a Cylinder, it must be attended with some Inconveniences in its Motion: But I shall not dwell upon this Point, it being my Design to treat of it here-under. You have the Construction of this *Fire-Ball* as follows.

After having taken the Diameter of the *Mortar* you are to use (see *Figure 143*) constitute a Parallelogram whose Length is Triple of its Breadth; such as you see in the Parallelogram G I K H: Its Breadth G H or I K is equal to C F the Semi-Diameter of the *Mortar*; B C being the Diameter of it. Its Length G I or H K is treble its Breadth, or $1 \frac{1}{2}$ of the Diameter B C. Then from the Points G and H describe the two Arches H D and G D, mutually intersecting each other in D: But from I and K you shall form the *Æquilateral Triangle* I K E.

By a Pattern of this Shape, you shall cut out six Pieces of strong Cloth, to make your Bag so as to fit the *Calibre* of the *Mortar*, which Pieces shall be artfully sewed together; leaving only an Opening at Top by which to put in your *Composition*. It shall be then corded as you see in Letter A.

Having done all this, you will have a Cylindric *Fire-Ball*, with a Spherical Head and a flat Bottom, which shall therefore be put into a flat-bottomed *Mortar*; some of which we shall give you in the *Second Part* of our *Artillery*, in our *Book of Mortars*.

C O R O L L A R Y I.

Of the several Shapes that may be given to the Pyrotechnical Projectiles; which of them are the best adapted to receive the Impressions of a moving Force, and to retain their Motion after it is once communicated.

THERE are many who are of Opinion, that such *Projectiles* as have a flat Bottom do not require so great a Quantity of *Powder*, to carry them to as great or even to a greater Distance, than those which are perfectly Spherical: This I shall demonstrate according to their Way of reasoning, without deviating in the least from their Arguments.

The Modern *Mortars* having their Lengths most commonly but 2 or $1 \frac{1}{2}$ of their Diameters respectively, and sometimes but one only; the *Powder* in their Chambers being inflamed, and accordingly striking against the *Ball* or *Bomb* to project it, does not act with its whole Strength

U u u upon

upon it, but the Flash endeavours to escape through the *Windage* of it, choosing rather to make its Excursion through a free Passage, than be obliged to remove the superincumbent Weight, and therefore does not strike the Bottom of it with all its Force. The Reason of which is, because though the Convexity of an Hemisphere is always double of its Base; (according to the Doctrine of *Archimedes*, *Prop. XXX* of the *Sphere*, and of the *Cylinder Lib. I.*) yet if from the Imaginary Points which the Base is composed of, you produce right Lines extending to the Convex Surface of the said Hemisphere, you will find that you cannot assign a greater Number of Points to its Convexity than to the Plane or Base upon which it rests. Now the farther any of these Perpendiculars are from a certain Line, which you must suppose to extend from the Center of the Base to the *Vertex* of the Hemisphere, the shorter will they be; and consequently, any one of the Imaginary Points on the Convexity of an Hemisphere being applied to any Plane, will immediately touch it, and be touched by it; but the Points or Extremities of the other Perpendiculars will be exempt from any Contact; because those Perpendiculars are shorter than the *Axis*, which is that Perpendicular we just now supposed to be in the Middle: Therefore there can be but one Point of Contact between any Plane, and the Convex Surface of an Hemisphere. You have this largely and curiously handled by *Clavius* in his 15th *Prop.* and 16th Book III. of *Euclid*: See also *Marius Betti-nus* Vol. III. Book III. in his *Schol. upon Prop. I. of Euclid* Book II and III, and in the following; as also in *Theodos. Tripol.* Book I. of *Spheres* *Prop. III.*

If now we suppose the *Moving † Power* of any *Gun-powder*, or the Flash of it, to extend itself in such a Form as to have a plane Superficies towards the *Projectile*; this Plane will strike and project it in a Point only: Therefore must we conclude that the whole impulsive Quality of it is not united, and that it acts upon a *Spherical Projectile* with only an aliquot Part of its whole Force; for a Plane is composed of an infinite Number of Points, whose Actions and Affections are all independent of each other; wherefore the Affection of the Central Point has nothing to do with that of the others extended all round it, nor has the least Communication with them; (but you must here make Allowance for the different degrees of the Natural Solidity of Bodies, which quite alter the Case) on the contrary they instantly move on, and dispersing into Rays which embrace the whole Convexity of the said *Projectile*, and acting in an oblique Direction upon the Points of the Convex Surface of it, they cannot be said to drive it out with their compleat Energy; for oblique Rays are stronger or weaker the more or less they decline from a strait or perpendicular Direction, the Truth of which may be demon-

† Where-ever in the Sequel you meet with the Terms *Moving Power*, *Moving Cause*, and such like, you are only to understand by them the *Flash* of the *Powder* in general; — These Terms are chosen to avoid *Tautology*.

strated from *Vitellio's Optics*, &c. Therefore we must conclude that the Flash of *Gun-powder* does not project a Spherical Body with its united Strength, and that a Sphere is almost unfit to receive the Impulse of it. But it is not thus with a Flat-bottomed *Projectile*; for as all the Perpendiculars which you may suppose to descend from the *Vertex* or Convexity of it, terminate in the Plane of its Base, and whose Points or Extremities compose the Flat Bottom of such a Body, the Plane Surface of the Flash must impel it with its full and united Power; for every Ray of it must of necessity strike some Point or other of the Bottom of such a *Projectile* in a right Direction, and rebound immediately back again, according to the Nature of the Rays of all *Luminous Bodies*, with whom (as we are taught by *Optics*) the Angle of Reflection is always equal to the Angle of Incidence. Wherefore all the Rays in general being confined and resisted by the Body they would project, and having no room to escape through the *Windage* of it, they unite their whole Might to remove the Obstacle which opposes their Freedom, and accordingly project it with prodigious Violence: And in this Case none of the Flash will appear out of the Muzzle, till the *Projectile* is departed from the Piece; nor will it wrap itself round the Sides of the projected Body, (as it does with respect to *Spheres* or *Spherical Balls*;) and soon after quitting it, retire to its Natural State of Rest; but will adhere to the Bottom of it, drive it forwards, and pursue it a considerable Way through the Air, in proportion to the Position or Elevation of the Piece, with regard to the Horizon.

Persons who are used to judge of Things by the Lump, may conclude the Arguments I have here produced to be just and well-grounded, and may conceive an Opinion that Flat-bottomed *Projectiles* have a great Advantage over the perfectly Spherical Bodies, or such as in any degree incline to that Form.

Therefore having thus demonstrated, as clearly and succinctly as I could, a Matter which seems to have some Truth on its Side, and which might be deemed a Fact by such as are dim-sighted in these Affairs: I shall do my utmost to evince that they are poor, lame, unpolished Arguments, which stand in great need of being filed and burnished.

In order to which we must examine into two Things (*viz.*) *First* the Nature of the Moving or Expulsive Power, the Properties, Qualities, and Manner of Action of the Flash of *Gun-powder*, and what Form it assumes when it projects any Bodies. *Secondly*, why (contrary to the above Arguments) a Spherical Body is more adapted to receive the Impulse of the Flash of *Gun-powder*, or any other Moving Cause, than a Flat-bottomed one; and how it comes to pass that the nearer a Body approaches to a Spherical Form, it is the more susceptible of Motion.

For the *First* of these: The Generation or Production of the Moving Power of *Gun-Powder* can be attributed to no other Cause, than to the Fire which insinuates itself into it, and changes the whole Substance of
it

it (it being naturally very subject to Transmutation) into another infinitely more subtile, and particularly into such as is most like itself, or which tends the most to its Conservation and Increase; for it is laid down as an infallible Maxim, that each *Element* endeavours as much as possible to reduce every thing to its own particular Substance, from a natural Inclination and Desire of Infinity and Eternity. This is amply verified in *Fire*, which has a boundless Ambition of surmounting and possessing itself of every Thing: And being (according to *Scaliger*) as it were the Prince of *Elements*, it greatly extends its Empire by a perpetual Domination, uniting some things, and separating others, and exerting its Power over whatever is within the Sphere of its Action, and accumulating whatever can be converted into its own Substance. Thus when it seizes upon Wood, it knows how to distribute the Humidity and Ashes to the *Earth*, the Exhalations to the *Air*, and never forgets to lay hold on what belongs to itself, which it takes Care to keep Possession of. The same may be said with regard to *Gun-powder*, whose Nature being perfectly Igneous, the Fire seizes upon the whole Body of it, excepting some little Smoke and Soot, generated by the *Coal*, and certain gross earthy Particles impregnated with the *Sulphur* and *Saltpeter*, which usually stick to the Inside of the Piece.

Therefore we will call this Virtue, and Moving Force of *Gun-powder*, a certain Natural Property of Fire, compounded of † another which is extremely Subtile of itself, (which obliges *Philosophers* to say that it neither burns nor shines) and which is Spirable, Violent, Impetuous, Active: Thus this compounded Force disperses, thickens, heats, rarifies and burns; is impatient of Opposition, incapable of Condensation, or Contraction. But I should never have done were I to give a particular Detail of all its Attributes!

Since now you have a pretty good Idea of this *Moving Cause*, which never had any thing comparable to it; it is necessary I should shew you its true and natural manner of acting; before I speak of its Form.

But I should think myself guilty of a very great Slight to the learned *Scaliger*, if I did not here recur to his Arguments; (though I should not be at a Loss to illustrate it myself) for I dare say, that no Man since *Aristotle*, has been so diligent an Observer of Things, or cultivated Natural Philosophy so effectually as that great and learned Person. He speaks thus, in his *Exercitat. XI. Not only Attraction but Impulsion is caused by Rarification, as may be seen in Brass Tubes filled with Saltpetrous Matter; for the Fire in its Rarification endeavouring to possess itself of the Places nearest to it, must necessarily repel and drive forwards; which cannot be properly attributed to Density: And because* (he speaks to *Cardan*) *this Doctrine of yours has gained ground*

† By this he means the *Flasulent Expansion* or the *Windy Exhalation* produced by the *Saltpeter*.

amongst the generality of People, I shall here particularly dwell upon it. You would have us understand it thus: (viz.) the Powder being converted into a Flash of Fire, cannot be contained in the narrow Space in which it was contained whilst it was Powder; therefore its Parts endeavour to condense; but because that is impossible, they break out with great violence. But you do not here perceive that the Rarification is Two-fold. The one being immediately joined to the Expulsion; for it could not fly out unless it was dilated: And the other which is the Cause of its Condensation, for it would not be condensed near the Bullet, except from its First Accension it was successively rarified. Thus is your Argument falsely grounded, and no ways Metaphysical, and all from your Ignorance in what concerns the Moving Cause: Indeed this Denfation is not only secondary but accidental also; it being a Privation of the natural Property of Fire, which is Rarification. By what Rule of Nature then can the Privation of the Natural Property of Fire, perform the Effect of it; which is Impulsion? Which Impulsion is owing to the Endeavour of the Form (or Body) to fill up its Place. Moreover, Rarification is a Motion, by which the Things rarified extend their Bounds: On the other hand, Condensation is a Motion by which their Bounds are contracted. Impulsion is a Promotion of the Extream. Therefore you are mistaken, to attribute this Motion to Condensation.

Here I would willingly check the Course of my Pen, were it not for the Nobleness of the Subject, which leads us on to a true Knowledge of the admirable Effects, and unspeakable Strength of *Balistræ*, † *Scorpionæ*, *Catapultæ*, *Bows*, and such like *Warlike Machines* (which we shall hereafter explain, and describe by the most Curious *Figures*;) in short, I find such Charms and secret Virtues in the Words of this Great Man, that I must let him pursue his Subject, whilst we follow him as close as our Apprehensions will permit. You are as much mistaken when you attribute the Motion of Impulsion in *Balistræ* to Rarification. For it is performed by Condensation; because whenever the Bow of a *Balistræ* unbends it Condenses. It is thereby made shorter, and consequently must be contracted. For which reason it breaks sometimes in the bending; because it is rarified. Now if you assert, that this Rarification is the Cause why the Bow unbends and condenses; you will raise two Objections against your self. And First: I shall deny that it can be any way attributed to it. It is neither Form nor Matter, but an Accident, and a Privation of Density, which is owing to the Bow. It is not the Effect: The Effect is Impulsion. Is it the Efficient Cause? I deny it. No Being can effect what is its contrary, or diametrically opposite to its Nature: No Privation can perform the Office of its Subject. Rarification is a Privation of Density. The other Objection is: If you will have this Rarification

† *Scorpionæ* were a Sort of Cross-bows with which the Ancients used to shoot Poisoned Arrows &c.

on to be the Cause of the Impulſion, becauſe it is Antecedent to the Condensation; you ſhould allow the ſame thing for Fire-Arms, in which the Rarification is always Antecedent to the Condensation. If a Bow be broken it is becauſe it is too much rarified. Therefore we find that Tough Things cannot be broken, becauſe of their Parts, which will admit of the utmoſt Extenſion or Rarification. Earthen Things break, and will not bend. Metals may be rarified, and are therefore flexible. Why do the ſame Bows break if you deprive them of the Spring-pin, the Nut or the Arrow? It is, becauſe whiſt they have any thing that retards their Contraction, they are contracted with leſs Violence; but when they are deſteſed of all Incumbrances, it is with a ſudden Motion that they unbend, and are therefore Broken. This alſo happens to Wooden Hoops, which if they be bent eaſily and gradually, they will follow the Circular Direction you would give them, but if they are ſuddenly bent they break. If it be allowed, that the Concavity of the Bow when bent is condensed, and on the contrary rarified in unbending; this will agree with us. Perhaps the Ratio of this Motion is in proportion to the exterior Circuit of the Bow. But ſome of the more Subtile may deny this Motion to be cauſed by Impulſion; but to the preceding Cauſe of Attraction. For the String impells the Arrow, becauſe it draws; and it draws becauſe it is drawn. The Traction or drawing of the String is the Firſt and Immediate Cauſe; the Traction of the Bow is the Second and Laſt. The Cauſe of the Traction is the return of the Bow to its Site or Rectitude, which cannot be done without Condensation. It is a Return of the whole, but a Condensation of Parts only. Truly this Motion is different only in Cauſe, and not in Effect. The Impulſion is a mere Effect, and the Condensation a mere Cauſe. The Traction is the Cauſe of the Impulſion, and the Effect of the Condensation. The String of the Bow is broken when it unbends without an Arrow, not for the ſame Reaſon that the Bow breaks (viz.) by Rarification, but by the Strength of the Bow which pulls it violently at each End, in endeavouring to return to its free State: But if the String breaks in bending the Bow, it is broken by Rarification.

Thus far Scaliger. I ſhall now reſume the Thread of my Eſſay, in order to which we will firſt conſider the Form and Figure of this Moving Cauſe which is generated by Gunpowder.

It cannot be doubted (if you conceive what has been ſaid above) that this Power is no other than Fire, or a certain inflamed Air or Vapour; ſince it is evident that Powder is almoſt all Fire in Power (as Metaphyſicians have it) before it is converted into a Flaſh, and by the Application of Fire to it, it actually turns into a Flame. From this it cannot be denied that it aſſumes the Form of Fire.

Now we have an infallible Argument to prove, that Gunpowder does aſſume the Form of Fire, from the nature of Saltpeter; which though it be derived from a Saline Humour, yet that Humour is not Aqueous but Aerial, and conſequently hot like Air, and bordering upon Fire:
and

and being violently and for some time beaten in a *Mortar*, it is greatly rarified and subtilized, by being devided of all gross and crude Particles which might be impregnated with it, and therefore still approaches nearer to *Fire*. Now to tell you that it is no way incommoded by being incorporated with *Coal* and *Sulphur*, would be a most needless Repetition of what I have already demonstrated.

Again; *Fire*, whether it be Natural, such as it is in its proper Sphere, (which is thought to be nearest to the Heavens) or whether it be Artificial, which is commonly called *Culinary Fire*; I say, whether it be Natural or Artificial, it is a *Body*. I need not go about to prove this Assertion, since it is allowed to be so by the joint Testimony of the Learned; and since it is a Fact, which is obvious to the Senses. Being a *Body*, it must necessary be finite, and circumscribed within certain Bounds. Thus *Philosophers* and *Geometricians* tell us, That a Superficies terminates a *Body*, a *Line* a *Superficies*, and a *Point* a *Line*: and that *Form* or *Figure* is made up of the different Dispositions of them. Therefore some of the Learned have attempted to represent the Elements under particular Forms, in imitation of other Natural Bodies: From whence it is that you have the Four Elementary Bodies of *Plato*, to which a Fifth has been added by his Disciples, as you will find in *Clavius Chap. 1. Sphær. Sacrob.* speaks of them to this Effect. *Plato represents Fire under the Figure of a Pyramid or a Tetrahedron, from its aspiring in a Point, or the Acuteness of its Flame. To the Air he attributes an Octahedron: For as Air is the next in order to Fire, so an Octahedron bears the greatest Resemblance to a Tetrahedron, it being composed of two Pyramids. To the Water he ascribes an Icosihedron, because of its great Mobility and Fluctuosity. To the Earth he allots an Hexahedron or Cube, because of its Immobility; for of all the Regular Bodies, a Cube is the least adapted to Motion. To the Heavens a Dodecahedron; for even as the whole Circuit of the Heavens contains 12 Equal Signs, so also a Dodecahedron is contained under 12 Equal Surfaces.*

But in the main you must look upon these Figures as Emblematical only: For who can believe that *Fire* artificially condensed in the Hollow of a *Cannon* or *Mortar* can assume the Form of a *Pyramid*? Or who can conceive that the Moving Cause, which (as I have often said) is a certain Windy Exhalation or Airy Expansion, can put on the Figure of an *Octahedron*? This it would be impossible for it to do, except when it enjoyed its perfect Liberty to mount upwards. And therefore *Fire* as well as *Water* being confined and compressed within any *Body*, puts on the Form of the Cavity wherein it is contained. As for Example, if the Windy Exhalation beforementioned, or rather the Flash of *Gunpowder*, was by any Artifice condensed within a Concave Sphere (such as our *Grenado's*) it would certainly assume a Spherical Figure; and so likewise when it is confined in the Chase of a Piece of Ordnance, it must take upon it the Form of a *Cylinder*.

As for the Figure of the *Vertex* of the Moving Power, or that End of it which strikes the *Projectile*, it is a difficult matter to ascertain any thing about it; nor can it be demonstrated any other way than by Conjecture, or by Comparisons instead of Arguments. It is very probable, that it endeavours as much as it can to enjoy its Natural Form; which it may do in Consideration that the *Projectile* resists it less than the Sides and Bottom of the Piece, and is not very capable of hindring it from assuming what Figure it will: From whence it is likely it may break out into a Cone or a Pyramid, which are Figures seemingly natural to it; add to which, that the main Strength would center in the *Vertex* of such Forms, which being repelled by the *Ball*, would return back again with redoubled Vigour against it (by means of its Rarification) after the manner of some *Purges*. On the other hand, it is not impossible but it may take upon it the Shape of an Hemisphere; which does not appear very unnatural to the Form of Fire and Air when in their proper Spheres, and is the strongest of all Figures and Bodies: From whence it is that Porters are naturally led to stoop to take up any Burthen, by which means all the Joints of the Body are collected as it were into a substantial Arch. The Fiction of *Atlas*, whom the Poets feigned to have supported the Earth upon his Shoulders, gives us a familiar Idea as to this Doubt.

But to give you the most certain and rational Explication of this Matter, and that which is the most universally received amongst *Naturalists*; we must first make a Distinction between the Situations and Positions of the *Projectiles* in our *Mortars*, from whence it will be conspicuous. You are to understand it thus.

All the *Mortars* with which we project *Pyroboical* Bodies (as we have often said) have certain Chambers, which are to contain the Requisite of *Powder* necessary to perform the Effect required. Suppose now that every Corn of *Powder* is at one Instant inflamed; and that the *Projectile* cannot be driven out by it, till it is become an Expulsive or Moving Power. Secondly, that your *Projectile* is perfectly Spherical, and that it immediately rests upon the *Powder*, without the Interposition of any Body between them. It is certain, that in this Case the Moving Power or Flash will not strike upon the whole inferior Hemisphere of the *Ball*, but on that Part of it only which stops up the Orifice of the Chamber, whose *Dimitient Line* is exactly $\frac{1}{2}$, or at least an Aliquot Part of the whole Diameter of the Superincumbent *Ball*. Now the *Ball* receives all the Impulse necessary for its Projection, before the Flash can make its Excursion out of the Chamber, and whilst the whole Energy of the Flash is confined in that narrow compass; which being once escaped from thence, it expands itself, and is consequently greatly weakened.

By this it appears that the first Shock is all that is needful, or requisite for the Projection of the Superincumbent Body. And if the Moving Force

Force or Flash is really collected into an Hemispherical or Pyramidical Form, it cannot be doubted (considering its Density whilst in the Chamber) that it would impel a round Body most powerfully, and hurry it out of the *Mortar*, &c. Nor must you imagine, that it acts with less Power than if the *Projectile* had been Flat-bottomed, for the Reasons above given; to which we may add, That the Flash being strongest, in its Excursion from the Chamber, it impresses its utmost Force, and consequently gives a sufficient Motion to both a Spherical and Flat-bottomed *Projectile*, by means of that Line only which passes through the Center of Gravity, round which all the Parts of the Projected Body are at rest. Moreover, as a Sphere represents a kind of Unity, which may be properly enough said to be but a Point; therefore if it be solid and made of any hard Substance, so that by the Solidity of its Matter and its Form, its Parts cannot be easily disjoined, it would be sufficient if it were struck in a Point only; for from that Point the Blow would be instantly communicated to all the rest. And I am really of Opinion, that this Impression would not have a more powerful Effect, if it had struck the whole Flat Bottom of any *Projectile*: But on the contrary I believe it would be much weaker; for in that Case (as I have already said) the *Powder* being extended, its Flash would not be collected into a Body of sufficient or at least so great Density, and consequently its Action would be fainter. Thus the Flat Superficies of the Flash (if it be a Plane) is no more adapted to impress a Force upon a Flat-bottomed *Projectile*, than upon any other.

Moreover, if any Body be placed beneath a *Spherical Projectile*, or one inclining to that Form; or beneath one that is *Flat-bottomed*, which is equal in Weight and alike in Substance with the Spherical one: As for Example, let us here suppose a Tompion to be driven upon the *Powder* in the Chamber in such a manner, that the Flash cannot immediately strike either the one or the other of the aforementioned *Projectiles*, and that it must give its Blow by means of the Tompion; I say, it is most certain that whatever Figure the Flash assumes upon its Ascension, it will impel and drive out the Tompion with all its Might, and that either of the *Projectiles* must equally share in the Impulse of the Tompion, though their Motion would be unequal, from the Inequality of their *Figure*, as shall be observed hereafter. What does it signify if the Tompion strikes a Flat Bottom in several Points, or but in one, as it does a Sphere? Since, as we have already said, any Point of a Sphere is as it were the whole Body of it, and *vice versa*, the whole Body of it as it were a Point: For nothing is separated from it, all its Parts are dependant upon each other, and the Excellence of its Figure admits of no Inequality or Defect in its Surface. As to the Reason, why the Flash, being escaped from the Chamber becomes weak, and unable to impress any violent Force upon a *Projectile* of any sort, I have sufficiently accounted for it already: But nevertheless I will once

more observe to you ; that the more the Flash is confined and resisted, the more furious does it become, and seems to be successively indued with new Degrees of Power, till it has forced its Way to Liberty. And it is for this Reason, that besides the Wooden Tompions which are driven into the Chambers of *Mortars*, they add certain round Boards, equal in Diameter to the Calibre of the *Mortar*, as we have said elsewhere. Therefore we may say that these round Boards supply the want of Flat Bottoms, since they prevent the Excursion of the least Atom of the Moving Power or Flash till the *Projectile* is departed. But they are of no farther Use after that Moment ; for it is impossible for them to pursue the projected Body with an equal Pace, whether they remain whole, or whether they be broken by the Violence of the Shock.

Upon the whole, it is an easy matter to prove that the Impulse of the Flash upon any Body is Instantaneous or Momentary, from the Example of such Things as are thrown by Hand, or shot from a Bow or a *Balista* ; which are never accompanied in their Projection by the *Moving Cause*, for it is sufficient that the degree of Force (let it be what it will) is once impressed. There are many of the Learned who maintain, that a Body being once put in Motion, would move on for ever, if its Motion was not destroyed by some Cause ; and they hold that this Assertion would obtain in a *Vacuum*, or a Space destitute of all sort of Resistance, that might obstruct and annihilate the Motion given ; which *Mersennus* thus accounts for : † *Whatever is produced cannot be destroyed, except it be attacked or affected by some destructive Cause ; for as no Being has the Power of generating or creating itself, so no Being can be supposed to procure its own Destruction. There are many great Men who think this to be true, since infallible Arguments to prove it may be deduced from what Ideas we have of it : For how can any Body be deprived of the Motion communicated to it, if it meets with no Obstruction or Cause which is destructive to it : For it may be supposed that God would no more deny his Assistance to Motion, which is a Thing of real Existence, than to other Beings ; how then can it be annihilated or suppressed if it meets with no Impediments ?*

Here I should be very willing explain how a Body moves or flies through a Resisting Medium (such as the Air) if I thought this a proper Place for such an Essay ; But as I think it is not ; I shall only remark, that Those are most strangely out of the Way, who perplex themselves in such inextricable Mistakes, as to imagine, that the Moving Power of *Gunpowder*, pursues the Body for some time during its Projection, and that adhering to it, it drives it on with fresh degrees of Velocity ; or at least assists it for some time, and prevents it from falling to the Ground so soon as it otherwise would : For what Man living is so ignorant, as not to be in some sort acquainted with the Nature of *Fire* ? or rather

† Mersen. in Phæno. Ballist. Prop. XXXVIII.

who is he, that has found an Art, or that is able to bind that Element, which is so Subtile, Volatile and Light, that Element which is so difficult to be handled, to a *Ball* violently hurried through the Air? Who obliges it to adhere to the *Projectile* without daring to forsake it? What magnetical Virtue can an *Iron Bullet* have, that should draw the Flash after it? But if I should grant all this, what would it signify? How could the Flash impress new degrees of Force upon the *Ball*, or by what Means could it superadd to the Motion at first communicated? Or how could it prevent the Motion from immediately forsaking the projected Body? For being once at full Liberty it becomes so subtile and rare, that it has none of that Strength it had at the Instant of its *Rarification*, which Strength consisted purely in its *Density*, and the compacted Union of its Parts: Those who are obstinately bigotted to this Opinion are no less mistaken, when they say that a *Gun* carries the further the longer it is; because the longer the Flash is confined in the Chase of the Piece, so much the longer does it attend the *Bullet*, and pursue it the closer. But we must in charity believe that the *poor Men*, who reason upon such a wretched foundation, are perfect Strangers to some *Rules* in our *Art*, which teach; That if a Piece of *Cannon* is made longer than ordinary, it is not because the Flash should thereby be enabled to project the *Bullet* with the greater Violence; but the Length is so proportioned, that the Requisite of *Powder* may be totally inflamed in the Chase of the Piece, and that at the Instant the *Projectile* is departing from the Muzzle of the *Gun*, the whole Power of the Flash may be united, and accordingly project it with its utmost Might.

And here I must inform you that the longer a *Cannon* is, so much greater ought its Requisite of *Powder* to be; and on the contrary, the shorter it is, the less *Powder* does it require. For even as too great a quantity of *Powder*, rather hinders than assists the Projection of the *Bullet*; because it cannot be totally inflamed at the Instant the *Ball* departs, and is therefore spilt upon the Ground (though some *Pyrobalists* have another way of accounting for this, which I shall touch upon hereafter;) so on the contrary, too small a Charge is totally accended before the *Bullet* has moved through the Chase of the Piece. I say then again, that the Flash which accompanies a *Bullet* through the Chase of a long *Gun* can by no means add to its Velocity, for the longer it remains in the Hollow or Chase of it after its Accension, and the more Room it has to expand itself, the more will it be rarified, and consequently it must be proportionably weaker: So that if there was a *Cannon* of 100 Foot in Length or more, whose *Calibre* would only receive a *Bullet* of 1 lb, which if it was allowed but the usual Requisite for such a *Ball*, which is 1 lb of *Powder*; I firmly believe that the Flash of such a Quantity, in accompanying the *Bullet* through so long a Chase, would be so very much weakened, that it would scarce be able

to drive it of the Piece, much lefs to project it to any great Distance. But we fhall have a more proper Opportunity to fpeak of the due Lengths of *Cannon*, together with the Weights and Sizes of their *Bullets*, and their Requisites of *Gun-powder*, in *Book I.* of the *Second Part* of our *Artillery*, where we fhall treat of *Cannon*.

Let what I have here faid fuffice at once to demonftrate and perfuade you, that *Pyrotechnic Projectiles* with Flat Bottoms are not near fo well adapted to conceive a Motion adequate to the Impulfe given, as thofe which are Spherical or inclining to that Form. Now that what I have faid is in every refpect true, I fhall appeal to the Demonftration of *Merfennus* in † *Mechan. Lib. II. Par. III. Prop. 6, 7 and 8*, where you may confult him.

From whence it will be evidently demonftrated, that any *Projectile* inclining to a Spherical Form, makes its Way through the Air with more Eafe, and penetrates through a *Medium* with lefs Difficulty, than a Cylinder with flat Bafes or Ends. But to this it may be objected, that a Cylinder may not always have one of its Ends foremoft, nor purfue its Courfe like an Arrow, for it may happen that its Convexity may cleave and rowl in the Air; and that it may alternately cut it with its Convex Surface, and alternately with its flat Ends. But to this I reply in the *firft Place*; that it is not impoffible but that the End of it which is turned Outward in the Piece may be driven on foremoft. 2. That, though the Cylinder fhould cleave the Air with its Convex Surface, yet that it would clear its Way with more Points than a Sphere; though they were both to be of equal Weight, and though the Height and Breadth of the Cylinder were to be equal to the Diameter of the Sphere. In this Cafe the Form of the Cylinder would be but little adapted to retain the Motion communicated to it. 3. That if the Cylinder fhould whirl round in fuch a manner, that its Convexity and Ends do alternately prefs forwards through the Air; it is very eafy to perceive, that there is but little difference between this Motion, and that by which it might move on directly with one of its Ends foremoft, for its Ends muft always meet with an equal Refiftance as well at one Time as at another. But be this as it will, and whether the Cylinder rowls and whirls about (which is an Action common to all Round Bodies) or not; it is certain that its Motion is in no refpect like that of a Sphere, and far from being equal to it.

Here by my own good Will could I filently pafs over feveral admirable Properties which are natural to a Spherical Figure; but I cannot forbear inferting what *Scaliger*, that Divine Spirit, has obferved concerning the Sphere, in his *Exercit. XXX.* 1. *With whatever Motion a Globe is turned, we always conceive it to generate a Form like itfelf.*

† The Original has here a long Quotation from *Merfennus*, which being in the main a mere Pedantic Repetition of what has already been faid, I thought it would rather perplex the Reader than help him.

2. Being whirled round upon a Point, it always fills or takes up the same Space, which also is common to a † Cone from its circular Figure: Again; if a Globe changes its place, it describes in the Air a Figure different from itself, (viz.) a Column; and at the same time forms a Line which is not in itself, but in Power. Being rowled or set upon a Plane it touches it only in one Point, in which wonderful Property it differs from all other Bodies: How then can a Solid Body rest upon that which has no Existence? 3. By one only Turn, it has two contrary Motions (namely) upwards and downwards with respect to its Circumference; (I do not here speak of the Heavens, but of any Ball or Wheel;) they are farther contrary, because the Downward Rotation is natural, and the Upward unnatural. 4. Notwithstanding that it is one continued Body, yet some of its Parts move with a greater Velocity than others: But you must here understand Velocity as Twofold; (namely) when Bodies, or Parts of Bodies, go through as much Space in less Time, or more in the same: Therefore the nearer its Parts are to the Outward Surface, the swifter they move; and the nearer they are to the Axis, the slower.

In short, the Circle and Sphere shall close up this *Corollary*, though they themselves are endless; and they will not only conclude this *Corollary*, but this present Year also (viz.) 1649; the last Hours of which our Press employs in printing these Lines. By God's Leave we shall to-morrow not only enter upon a new *Corollary*, but a new Year also, a Year of Benediction, the great Year of *Jubilee*, so long wished for by the Christian World! The *Almighty*, who has neither Beginning nor End, has this Day compleated the Circle of a wonderful Work, in which every living Soul must hold its Course without exceeding the circumscribed Bounds of it. To-morrow we shall begin a New Year, which I wish may be pregnant of Happiness, Peace and Joy throughout the whole Face of the Earth: Humbly beseeching the *ineffable Goodness*, that fixing one Foot of the *Compasses* of his Love in our Hearts and in our Souls, he would with the other describe a new Circle, which may excite new Degrees of Velocity in us, and hasten us on in an immediate Tendency, towards the endless Bliss of a blessed Eternity; to the End, that being far removed from the first Point of that Impulse, which naturally urges us to pursue and covet the Vicissitudes of Worldly Fortune, we may no longer be exposed to Danger amidst the Rocks and Shelves of our Folly: But that on the contrary, continually revolving in an endless circular Direction upon the smooth Planes of *Fortitude* and *Constancy*, we may at length resume the Place from whence we set out (namely) *Heaven*, there to enjoy Eternal Life.

† The *Latin* has it *Pyramis*, and the *French* Translator has rendered it *Pyramide*; but *Scaliger* to be sure means a *Cone*, which is by *Mathematicians* often defined to be a *Pyramid* of Infinite Sides.

COROLLARY II.

Of several Sorts of Pyrotechnic Petards or Crackers prepared for various Military Uses.

PYROTECHNICIANS have several other Sorts of *Crackers*, besides what we described in treating of *Fire-Balls*. But as in undertaking this Work, I only propos'd to dwell upon the chief *Pyrotechnical Inventions*, and such as are the most frequently used; therefore rejecting those which are the most inconsiderable, and least useful, I shall refer our *Pyrotechnician* to those *Figures* which he sees under Number Fig. 151. 151. distinguished by the Letters A, B, C, D, E, F, G, H, I, K, L. The first of them (*viz.*) A, is in no respect different from that we gave you under Fig. 137: This will not only serve for *Fire-Balls*, but also for *Garlands, Crowns, Bags, Fire-Hoops, Lances and Darts*; as may also the two following distinguished by B and C, notwithstanding that they differ a little from the first. The Proportions of *Crackers* shall be determined by the Size of the Body whose Use you intend them for: But if you would have one fix'd determinate Proportion, you may allow their Orifices the Diameter of a *Leaden Bullet* of one Ounce, or two at the most; and their Length or Height shall be 5 Diameters, without reckoning the Point. This is the most just and proper Proportion that can be ascertained for them. As for the Loading of them, please to look back on what we have already said, to save us the Trouble of a tiresome Repetition.

The other *Crackers* which you see, are much larger than the above-mentioned, and serve commonly for *Wooden Balls, &c.* the Construction of which we shall give you in the following *Chapters*: The first of these (*viz.*) D, is perfectly like the *Recreative Cracker* which we gave you in *Figure 107* under the Letter A. The Construction of this is very easy, and the *Figure* of it is very intelligible. It is usually charged with *Corn Powder* to $\frac{2}{3}$ of its Height, and the Remainder of it is loaded with *Leaden Bullets*, then stopp'd up with a Wadd of Paper or Tow.

That which you see in Letter E is a Triple one, that is, it contains two others less than itself; though simply of itself it is perfectly like that which we just now described, (*viz.*) D. This is pierced with five small Holes, for fear it should miss Fire; four of which are in the Sides, and Diametrically opposite to each other, and the Fifth in the Middle of the Bottom of it. As for those distinguished by F and G, they are almost like those which we formerly represented under Fig. 106. These

three

three then shall be ordered, that the Second may go into the First, and the Third into the Second. The greatest of them (*viz.*) E, is generally filled with *Corn Powder* to half its Height; upon which you shall slip down the Middling one, into which you must put the Least, filled with *Corn Powder*, and some *Leaden Bullets*, after having filled the Second with *Corn Powder* in the same manner you did the First; I mean that Vacancy of it which exceeds the Height of the Least. Moreover, the Middling one as well as the Least have Chambers filled with one of the *Slow Compositions* I have already given.

The Third *Cracker* which you have in H, represents a little Copper or Iron Tube without Bottoms. When you would load this, you must divide the whole Height of it into 3 equal Parts, whereof that in the Middle shall be filled up with *Corn Powder*, and the other two with *Leaden Balls*. You are to separate them from the *Powder* with Paper Wadds; they shall likewise be wadded at each End. You shall make two Touch-holes, or more if you will, just in the Middle of this *Cracker*.

The Fourth of them, (*viz.*) I, needs no Explanation; for it is to be ordered exactly like those whose Profils you have in F and G; though it must be confessed that it differs from them so far as to be used singly, admitting no others into its Capacity, and must not on the other hand be lodged in any other when it is to be put in Execution.

In short, the *Crackers* K and L, one of which is in the Shape of a Cross, and the other of a Carpenter's Square, are to be loaded like the rest, with one or more *Leaden Balls* according to their Capacities. I shall leave the rest of their Construction to the diligent and ingenious Workman.

C O R O L L A R Y I I I .

Of the several Sorts of Lacings, Mattings, and Ligatures of Fire-Balls, and the Terms sutable to each of them.

I Find nothing more difficult in the right treating of *Arts* and *Sciences*, than to express myself in proper Terms, and to call those Things by proper Appellations which we know nothing of but by continual handling of them; for scarce can our Eyes (which are Witnesses and Examiners of Things) give a faithful Account of them to our Judgment. In truth, Manual Practice is of such great Importance, and bears so large a Share in all *Arts*, that if you cannot execute with your Hand what you have conceived in your Mind, you must look upon yourself as having a Soul without a Body. But as Design and Drawing contribute greatly

greatly towards furnishing us with proper Conceptions of Things, I have represented to you the several Sorts of *Lacings* or *Mattings* of *Balls*, in the most familiar manner the Nature of the Work would admit of.

Pyrotechnicians have given Names to the several Sorts of these, according to the Fashion they are wrought in: The first and most simple of which you have in *Fig. 136* and *138*, which the *Germans* call *Reibbont*. The Second with its various Interweavings, which you have in *Fig. 137*, they call *Fallen-bundt*. That in *Fig. 142* differs in nothing from this. In short, the strongest and most artificial of them, which you have in *Fig. 140* and *144*, the First being wrought in Fashion of a Rose, and the other of a Snail, they call *Rosfen*, and *Schnecken-bunt*. But I refer you to skilful *Pyrobolists* for an ample Information of what farther relates to this matter; as for me, I am in haste to do other Business.

C H A P. VI.

Of a Wooden Ball filled with Hand-Grenado's, or a ‡ Thundering Ball.

JUST as in *Pyrotechnics*, *Hand-Grenado's* are variously applied, so their Uses in Warlike Occurrences are very different. You need only have a skilful Artist to put them in Execution at proper Times and Places. Now of all the Contrivances for shooting several *Grenado's* at one Projection, I approve of the following the most.

Fig. 152. You shall have an hollow *Wooden Ball*, whose whole Height shall be to its Breadth (which must be regulated by the *Calibre* of the *Mortar*) in a *Supertripartient* Proportion; that is, as 7 is to 4, though a *Sesquialteral* Proportion might do pretty well. The Bottom of it shall be half a Diameter in Thickness, to be the better able to withstand the Shock of the *Flash*, and shall be rounded without and flat within. The Head or Cover of it must be a Concave Hemisphere, and shall be fitted to the Body of the *Ball* by a very nice Joint.

The *Vent* of it shall have a *Fuze* made either of Wood, Iron or Copper, whose Height shall be half of the whole Cavity of the *Ball*, and its whole Breadth shall be of the same Dimensions with the Sides of the *Ball*, which must be $\frac{1}{2}$ of the whole Diameter of it. This *Fuze* must be filled with one of the ordinary *Compositions* for *Fuzes*.

‡ I think this may as well be called a *Thundering Ball*, as a Barrel full of *Grenado's* is called a *Thundering Barrel*.

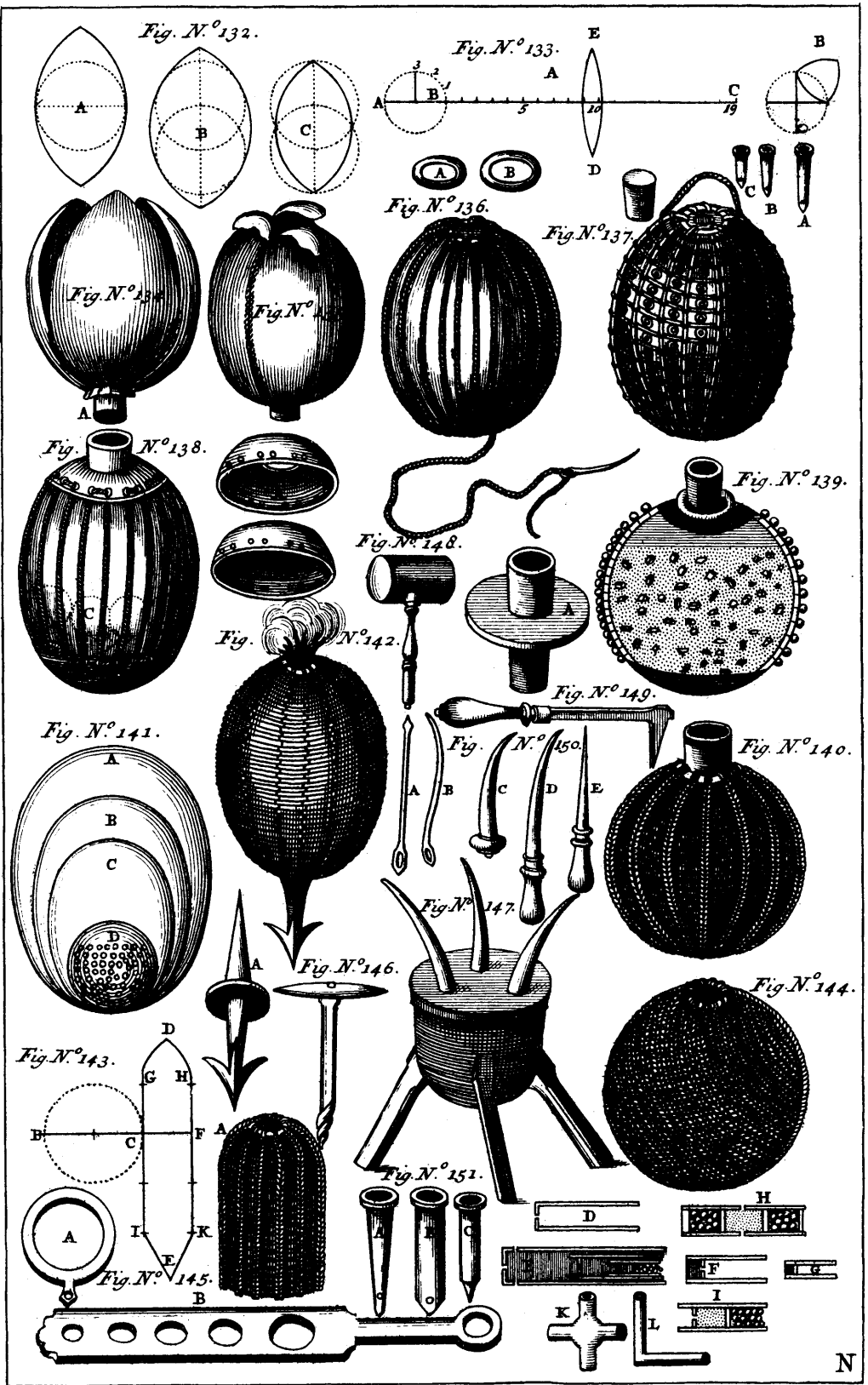

The whole Body of it shall be filled with *Hand-Grenado's*, and the Interstices between them shall be filled up with *Corn Powder*. Above all things you must take Care, that all the little Fuzes of the *Grenado's* be turned towards the Bottom of the great one in the Middle of them all, that they may not fail of taking Fire.

The whole being thus ordered, and the Head of the *Ball* firmly glued on, it shall be dawbed over with Tar, and coated with a Cloth dipped in the same: The *Figure* will give you a clear Idea of every thing relating to this:

C H A P. VII.

Of a Globe or Ball composed by several others.

THIS *Ball* which I represent to you in *Fig. 153*, is nearly both in *Fig. 153*. Form and Effect like the *Fire-Ball* I gave you in *Fig. 141*: Therefore I shall refer you to what I said of that, in regulating the Proportions of the Lesser *Balls* contained in the Greater: But you must at the same time observe the following Particulars.

1. You may take *Balls* of what Sizes you please; but the Thickness of their Shells shall (according to our *Figure*) be $\frac{1}{2}$ of their Diameters, but it may be more or less if you please.

2. The *Balls* shall be perfectly round, as well on Account of the Capacity of that *Figure*, as for several other Reasons already given.

3. The Hemispheres of the three *Balls* B, C, D, shall exactly fit each other; but the Fourth, (*viz.*) A, shall be only an *Iron Grenado*, whose Convexity is armed with *Leaden Bullets*; though by the way, the other three may be made of Iron if you think proper. But let us suppose them to be of Wood (which will not be very despicable:) You shall fill them with *Corn Powder*, and some of those Iron or Copper *Crackers*, which we described above in Number 151, under the Letters D, E, H, I, K, L; and then glew the Joints of their Hemispheres carefully together: The *Figure* will teach you how to fix them in one another: But I must warn you to let the *Grenado* in the least of the three be fixed and immovable, and to let the Head of its Fuze be placed exactly under the Bottom of the Fuze of the *Ball* it is contained in. Each of your Wooden *Balls* shall be afterwards re-inforced with pliable Iron Plates of two or three Fingers Breadth, and then well coated round with a Tarr'd Cloth: Or they may be laced with a Cord like the *Fire-Balls*. If they are all made of Iron, you need only solder the Joints of the Hemispheres; though I am afraid the Soldering would break by the violent Shock of the Fall: Therefore in such a Case it

A a a a

would

would be proper to coat them with a *Rose Matting*, which is the strongest of all.

4. The Fuzes for these must be in Proportion to the Sizes of the *Balls*, and in the same manner as we have directed elsewhere, and filled with one of the ordinary *Compositions* we have already given for the Fuzes of *Grenado's*.

It were needless to amplify upon the wonderful Effects of this compounded *Ball*: But I will venture to say, if it be thrown in this Condition into the midst of the Enemy, so as to take them unprepared, it will kill as many Men, and do as much Execution, as the Fire of an hundred Musqueteers could do upon a whole Battalion.

Observe here in the *first* Place, that I have represented but three *Balls* inclosed in a Greater: But you may have more if you please, provided they are in due Proportions to that which is to contain them all, whose Size must be always regulated by the *Calibre* of the *Mortar* they are to be projected from.

Observe here in the *second* Place, That if you should not have *Mortars*, these *Balls* may be conveniently shot from a *Balista*; if you think proper to revive the Use of that *Machine*: But I apprehend that this Project will excite the Laughter of some *poor Hearts*, who cannot see beyond the Tip of the Nose; however, let them laugh or rail on, since it is an unalterable Decree that Fools should always rise up against *Truth*, and since Ignorance so weakens the Faculties, as to render them incapable of bearing the Light of *Reason*, who is the Daughter of *Truth*, who also is too bright and powerful for their weak Eyes. For my part, I have a due Regard for the Judgment of those great Persons, who had a perfect Knowledge both of the Ancient and Modern *Arts of War*, without undertaking to persuade those Spirits of Contradiction, who approve of nothing but what is done by themselves.

Observe in the *third* Place, that these *Balls* may be projected by one or two Fires, just like *Grenado's* or *Fire-Balls*; but they shall (if they be made of Wood) be re-inforced with such Iron Basons as we formerly mentioned, to enable them the better to withstand the Shock of the Flash.

C H A P. VIII.

Of FIRE-RAIN.

PYROBOLISTS, amongst many other Inventions, have contrived a certain artificial Fire, which they throw at a Distance into besieged Places, (and particularly when the Buildings are covered with Shingle and Laths, or thatched with Straw or Reeds,) which they call

Fire-

Fire-Rain, and which the *Germans* also call *Fewer Regen*. The Preparation or Confection of this is very common, and well known,

Melt 24 lb of *Sulphur* in a shallow Earthen Pan, over a very clear Fire, free from Flame or Smoke; and as it melts throw into it 16 lb of *Saltpeter* and mix them well together with an Iron *Spatula*: As soon as they are melted take them off the Fire, and add to them 8 lb of *Corn Powder*; mix them all well together, and being cooled pour out this *Composition* upon Polished Marble, or Plates of any Metal; and then divide it into Pieces of the bigness of a Walnut or Crab; and wrapping them up in *Quick Tow*, and salting them over with *Meal Powder*, put them into a Wooden Ball, (such as you see in *Fig. 154*, which must be of *Fig. 154* the same Dimensions with the *Recreative Aerial Balls*, under *Fig. 96*, and *97*.) and fill up the Interstices between with good *Corn Powder*, and cover them closely and firmly up, and coat the whole with a Tarr'd Cloth.

The Priming Chamber and Fuze shall be filled with one of those *Compositions* which we ordered for the same purpose with regard to *Aerial Recreative Balls*, or else with one of the common Fuze *Compositions* for *Grenado's*. In short, as for any thing else relating to this *Ball*, I refer you to the Figures beforementioned.

I must only warn you of one thing, which is, that the *Mortar* must be fixed at such an Elevation that the *Ball* may break in the Air; upon which you will immediately see a *Rain of Fire*, descend, and scatter abroad: Thus falling and spreading over several Buildings, it will set them on Fire with the same Ease and Certainty as if the whole *Ball* had fallen upon one in particular.

Besides the above *Composition* (which the *Germans* call *Geschmoltzenzeug*) you may use one of the following, which must be prepared in the same manner we just now directed.

I.

Take of *Sulphur* 3 lb, of *Saltpeter* 1 lb, of *Corn Powder* 1 lb, of Filings of *Iron* or *Hammer-flaw* lb ss, and of *Powder of Glass* lb ss.

II.

Take of *Sulphur* 1 lb, of *Saltpeter* 1 lb, and of *Corn Powder* 1 lb.

These two *Compositions* I have borrowed from *Joseph Furtenbach*, as well as the following; which become very Slimy and Viscous, when dissolved by Fire, and that in so remarkable a degree that what with their Slowness and Tenacity, it is impossible to tear them off from any Place after they have once stuck to it: Those who are knowing in this *Art* assure us (with our Author) that these *Compositions* will burn through a pretty strong Iron Cuirass; and having myself experimented them upon a Copper Plate of about the Thickness of a *Line*, I can venture to recommend them to you.

III. Take

III.

Take of Sulphur \bar{z} j, of Galbanum \bar{z} iiij, of Saltpeter \bar{z} iiij, and of Corn Powder \bar{z} iiij.

IV.

Take of Sulphur \bar{z} v, of Saltpeter \bar{z} ij, of Colophone \bar{z} j, of Corn Powder \bar{z} ifs.

In † *La Port's Natural Magic* we find two *Compositions* exactly like these, which he gives us in the following Terms. *Warlike Machines are sometimes charged with these Compositions; from whence they shoot certain Balls of Fire, which break; (Here he agrees very well with us) they are prepared as follows. This Powder is wrapped up in Tow, steeped in the Mixture we have already mentioned; (He just before gives us a wonderful Composition which burns in Water) they load their Machines with Balls steeped in this Mixture, and project them at the Enemy. Sometimes instead of Oil, and to make them more Fiery, they substitute Swines Fat, or Goose Grease, with Sulphur Vivum, or Quick Sulphur (which the Greeks call $\alpha\rho\upsilon\epsilon\omicron\rho$) Oil of Sulphur and Petrol; Saltpeter highly refined; Rosin of Turpentine, of Tar, Oil of Eggs, and sometimes to give it a Consistence they add Raspings of Lawrel or Bay: These being shut up in a Glass Vessel, must be buried under a Dung-hil or a Dung-beat for two or three Months, renewing it every Ten Days, and shaking the Composition. After which if the Composition be fired, it burns till it is totally consumed, and is rather increased than repressed by the throwing of Water upon it; but may be totally suffocated by Dirt, Earth or Dust &c. If it falls upon Armour, the Men look as if they were on fire, and must be either burnt alive, or else throw their Armour away.*

We shall give you another whose Effects are still more extraordinary. Take of Turpentine, of Tar, of Varnish, of Pitch, of Frankincense, and of Camphire each one Part; of Sulphur Vivum $1\frac{1}{2}$ Part, of Saltpeter doubly clarified 2 Parts, of Brandy 3 Parts, with as much Oil of Petrol or Naptha; to which you may add a little Dust of Willow Coal. Mix these well together and make them up in Balls, or fill little Pots with them, and they will burn with inextinguishable Rage. Whoever has the Leisure and Conveniency of trying these Compositions will find them to answer what is said of them.

COROLLARY I.

The *Compositions* I have now given you (excepting the two last, which I took from *La Porte*) must necessarily be melted, and well incorporated together, in doing of which it must be owned that you will run great danger of being burned; and I remember to have seen *Pyrobolists* who have met with that Misfortune for want of due Care and

† Jo. Bap. De la Port. Lib. II. Cap. X.

Precaution. Now to avoid all such sad Accidents, I shall subjoin a *Composition* which stands in no need of being melted at all, and is to the full as effectual as the Former.

Take of *Sulphur* 16 lb, of *Saltpeter* 8 lb; of *Crude Antimony* 2 lb, and of *Corn Powder* 4 lb; beat, mix and incorporate these well together: Then dissolve common *Glue* in Boiling Water, or (if you will) *Gum Arabic*, or that of the *Plumtree* or *Cherrytree* in Cold or Lukewarm Water, and pour it upon your *Composition* in a glazed Earthen Pan; mix the whole well together either with your Hands or a *Spatula*, and make it up in Balls of what Sizes you please; or to expedite your Work, pour out your *Composition* upon an Iron Plate, and cut it out in Lumps, and set them to dry in the Sun, or in a Fire-pan, where they may dry by slow degrees. In short, when you would use them you must observe the *Rules* already laid down for their Projection.

C O R O L L A R Y II.

History will bear witness, that this *Fire-Rain* which we have so amply dwelt upon, derives its Origin from the *Grecian Fire* of the Ancients. Some (as I have already observed *Chap. I. of Book II.*) attribute the Invention of it to one *Marcus Gracchus*; but *Johan Zonaras* assures us it was invented before the Time of *Constantine Pogonatos* Emperor of Greece. *Nicetas Choniates* in *Iaacio* speaks thus of it. *They threw amongst the poor Inhabitans of the Sea-Coasts a certain kind of Grecian Fire which was held in Pots, and which suddenly broke out like Thunder, and set Fire to whatever it could reach.*

Others have called this *Grecian Fire* *πύργος* (which is as much as to say) *Wet Fire*, because it was observed to burn upon Water, and powerfully to repel all Moisture. Now to keep my word with you, I shall give you the *Confession* of it, just as I took it from *Scaliger*: † *Now for Fires and Fiery Compositions, which you undertake to instruct us in; (he speaks to Cardan) but I wonder you have not yet discovered how they are called. We have many Writings extant which call them Grecian Fires; one or two of which I shall willingly subjoin, as I took them formerly from some Arabic Books. Fire which destroys Iron was invented by the Son of Amram. Take of Tar, (it is thus I interpret Zerf) of Gum Juniper, which is also called Samag Agar, and corruptedly Sandarax, Oil of Turpentine, Oil of Bitumen, Oil of Sulphur, Oil of Nitre, or Saltpeter, Oil of Eggs, and of Oil of Lawrel or Bay, each Six Parts. Powder of Dhmeft or dry Bays, and of Camphire macerated in Brandy; of each 14 Parts. Of Saltpeter, to the whole Weight of them all. Put all these into a Glass Vessel with a narrow Neck well luted and stopped up, then bury it in Horse-Dung for 6 Months. This Composition shall be shaken every fourth Day, and then Distilled in ‡ Seraphino. We have a Description*

† Exercit. XIII. ‡ I take this Term to be of Hebrew Extraction, and to signifie no more than distilling it over a Fire.

of another sort in the Catalan Tongue. The Residuum of Turpentine after the Oil of it is drawn off, Oil of Turpentine; of Tar, of Rosin or Pitch of Cedar, of Camphire, of Bitumen, of Mummy, of New Wax, of Duck's Grease, of Pigeon's-Dung, Oil of Sulphur Vivum, Oils of Juniper, of Lawrel, of Linseed, of Hempseed, of Petrol, Oil of Tyles, and of Oil of the Yolks of Eggs, each half a Pound. Of Saltpeter 10 lb; of Sal Armoniac 7 Ounces. Let all these soak in Brandy in such manner as to be covered by it; then buried in Horse Dung, and renew it every third Day. Then draw off the Spirit a Seraphino, which you shall thicken with Ox Dung reduced to a very fine Powder: It is this that Semimaurus calls Miraculous; either because it takes Fire by the Heat of the Sun, or is not to be suppressed by any means, but by Vinegar, Urine, or Dirt: It burns obstinately in Water. These Fires are thrown in Pots at the Enemy, which sort of Pots was called by the Greeks, ἀστράχου.

It appears then that the Grecian Fires had the same Effect, and were applied to the same Uses as our Fire-Rain (namely) to set Fire to besieged Places: But there is one Thing which I stumble at; for to tell you the plain Truth, I cannot well conceive how this Fire could be hid and stifled (as Nicetas Choniates says above) so as not to perform its Effect before it reached the Place at which it was thrown. Were the Vessels it was thrown in contrived after some such manner as those Grenado's which we have called Blind? Or were they made of Clay, and ordered like our Fire-Pots with lighted Match, &c? Or (what I am most inclined to believe) did they fire the Matter in these Pots, before they were projected towards the Places they were designed for?

For my part, I cannot perceive what should oblige them to break, if they were not made of Clay or Wood; for it would be impossible for this Igneous Stuff to break them by its own Strength, had they been made of Iron or Copper; inasmuch as its Power extended to a certain degree of Violence, and inasmuch as it was susceptible of an inextinguishable Fire: For notwithstanding that it had a good Quantity of our Gun-powder Ingredients in it, (which I doubt) it would not be strong enough to burst Pots made of any hard Metallic Substance, as is done by our Powder, to whom alone that Power is granted, and denied to all other Things whether Natural or Artificial. There have been those who have related Wonders concerning the strange Effects of *Aurum Fulminans*, by which it seems even to surpass Gun-powder (to which I have partly consented:) But as its Operations are directly opposite to those of Powder, and since it is of no Use in our Fire-Works, we will not give it a Place amongst these combustible Things. But to return to our Grecian Fire; we have a familiar Instance of the natural Imbecility of it, in our Pyrotechnic Compositions which we call Slow, which (besides that they are compounded of some of the same Ingredients as the said Fire,) are made up not only of Saltpeter but also of Meal Powder, and even a Portion of the same in Corns; yet if you fill a Fuze or a Shell with them,

them, they will burn without doing the least Damage to the Vessels which contain them, except they are very thin and flight, or are not well re-inforced with a proper Coating, or except the Fire is too much confined. Moreover, we make *Slow Composition of Meal Powder* only, which if it be put into Wooden or Paper Cases, and fired, it will not in the least hurt them: How little then would it be able to burst Vessels made of Iron or Brass, like our *Grenado's*, which are with difficulty affected even by our *Corn Powder*? For I must remind you, that whenever the *Corns* of our *Powder* are disfigured, they are divested of their Strength, and are so far from being able to break Vessels made of Metal, that they would not split them if made of Wood, provided they are of moderate Thickness, well coated with tarred Cloth, and re-inforced with strong Cord or Marline.

We will conclude then, that the Vessels which held the *Grecian Fire* were made of some Wood or Metal, and that they were open, and not covered up like our *Fire-Pots*, which are at present in such great Request with us. Say we farther; that the Matter contained in them was covered by some very *Slow Composition*, to prevent the Fire from seizing upon it, before it had arrived at its intended Length. Or else we must believe, that it was covered by some sort of Sponge, or that it had lighted Match in the Mouth of the Vessel, which perhaps was covered with a Cloth, or some loose Wooden Lid; and thus the Matter being accended, flew out impetuously, and consequently burned and destroyed every thing within its reach.

However I do not deny, but those who used this *Composition* might be ingenious enough, to contrive that these Pots of Earth or Wood should break in the *Air*, from whence the Matter they contained, falling and scattering abroad unlighted; it would be impossible to see it fall, or to distinguish it after it was fallen, and accordingly at first it did no Damage: But being soon afterwards kindled by the Heat of the Sun (which is not impossible, according to *Scaliger*) or accended by the Wind, or Rain, or Dew (I shall give you some such *Compositions* hereafter) it must consequently take Fire, and burn whatever it fell upon. Now perceiving that *Compositions* of this Nature made into Lumps or Cubes, and shut up in a Wooden Ball, may be scattered abroad in the Air by *Gunpowder*, and fall down lighted or unlighted into besieged Places; I thought it would not be amiss to insert the following *Compositions*, and to instruct you in the Confection of them, according to the Directions left us by Authors; notwithstanding that what I have already given you from *Scaliger* is none of the most unfit for our Purpose.

La Porte saith: † *There is a Composition which catches Fire by the Heat of the Sun; particularly in those Regions where the Sun is very powerful; which must be compounded of very Igneous Ingredients; for Ex-*

† Joh. Bap. de la Port. Lib. II. Cap. X.

ample: Take of Camphire, of Sulphur Vivum, of Turpentine, of Gum Juniper, and Oil of the Yolks of Eggs; together with Tar; Powder of Colophone, of Saltpeter, and of Brandy to the double of them all, and a little Arfenic with as much Tartar: All these being pounded and well mixed, put them into a Glass Vessel, and bury it for two Months under a Horse Dung-hill, which must be frequently renewed, and the Composition as often shaken: Then draw off the Liquid Part of it in the same Vessel it had been buried in, (as we shall shew hereafter) which Liquid shall be thickned with some of our Powder (he means a certain Powder which he had just before mentioned for Water-Balls) or with Pigeon's Dung finely pulverized, so as to give it a pretty dense Consistence. (This may be made up in little Lumps.) With this dawb over all the Wooden Work or combustible part of a House upon some hot Summer's Day. All this is ascribed to Marcus Gracchus. Pigeon's Dung is of a very fiery Nature: (I must observe here that the Dung of Geese, Ducks, Hens, &c. being well dried, is also very combustible; but he goes on) Galen relates, that in Mysia, which is a part of Asia, there was a House burnt by the following Accident. A Parcel of Pigeon's Dung being thrown under a Wooden Window, which had been lately done over with Rosin, so as to touch it: This Dung being rotted, and much heated by the Sun upon a very warm Day, and emitting very hot Vapours, the Window took Fire, which soon after got hold on the Roof, and in a little time spread all over the House.

The same Author saith in the same Place: *That if you would make a Fire which shall be extinguished by Oil, and accended by Water, you must confect it of such Things as burn the most readily in Water, or that burn in it of their own Accord, such as Camphire and Quick Lime: From whence it is that if you make a Composition of Wax, Petrol, and Sulphur, it will be extinguished by Oil or Dirt; but if you throw Water upon it, it will revive and burn with renewed Vigour. Of this Composition they make Torches which burn in great Rains, or in crossing of Rivers. Livy tells us, that certain old Women, at a time when they were celebrating their Games, took Torches made of this, and swam over the Tyber with them, by way of Miracle.*

Cardan saith: † *That Water accends violent Fires; because the Moisture it exhales is rendered more Fat and Greasy, and is not wasted or destroyed by circumfused Smoke, but is totally devoured by the Fire; from whence being purified, and united by the Cold, it springs up with the greater Alacrity; and therefore those Fires which are excited or accended by Water, shall be compounded of Ship or Greek Pitch, of Sulphur, of the Lees of Wine, commonly called Tartar, Sarcocolla, Saltpeter and Petrol: (all this is attributed to Marcus Gracchus.) To these must be added a double Portion of Quick Lime, and the Yolks of Eggs; these must be mixed well together, and buried in Horse-Dung.*

† Card. Subt.

The same Author in the same Place: *Take Oil of Petrol, Oil of Juniper and Saltpeter, of each equal Parts; of black Pitch, of the Grease of Geese and Ducks, of Pigeon's Dung, of Liquid Varnish, the same Parts of each; of Asphaltites or Bitumen five Parts; put them all into Brandy, and bury them in Horse-Dung.*

The same Author in the same Place again: *Take of Liquid Varnish, of Oil of Sulphur and Juniper, Oil of Linseed and Petrol, and of Turpentine, equal Parts of each; of Brandy $3\frac{1}{2}$ Parts: Then of Saltpeter and dry Lawrel Wood both well powdered, enough to thicken the Whole, and give it the Consistence of a Lute. Put all these into a Glass Vessel, and bury them three Months in Horse-Dung. If the Balls made of this stick to any Wood, they will be accended by Rain: However, they will not always answer to this Effect; but being once enkindled, they never fail to burn in such a manner, that it will be to no purpose to endeavour at extinguishing them by Water.*

Scaliger saith: † *I afterwards met with a little Book which teaches how to make several Sorts of Salt, and Alum, and to confect a Fire which will be accended by Spittle, and was frequently used by Thieves and Robbers: (Pyrobolists may use this in the honourable Robberies of War.) Take Oil of Sulphur, of Turpentine, of Cedar, and Tar, of each 14 Ounces; of Saltpeter 16 Ounces; Sal Armoniac, Vitriol, calcined Tartar, of each 8 Ounces; calcined Loadstone, Quick Lime of River Pebbles, of each half an Ounce; Tallow and Duck's Grease, of each 6 Ounces. Being all covered with Brandy, bury them in Horse-Dung for three Months, (in the Margin it was written in the ‡ Dung of a Mare with Foal.) It must be shaken every fourth Day, then heated over a Fire that the Liquid Part of it may evaporate, and the Fæces or hard Part remain behind: Then break the Vessel to get at it, and pulverize it. If the Powder of this be scattered over Water it burns vehemently. This I have inserted to evince how great an Enemy I am to Juglers and Mountebanks; upon which Account also I shall add a Fable framed by Ct. Cnidius: This worthy Gentleman pretended that he knew how to extract an Oil, from a certain River Worm of India, with which the Kings of Persia used to burn the Enemy's Towns, by only dawbing or sprinkling them over it.*

Ælian. Lib. V. Hist. Arim. Cap. V. & Ammianus Lib. XXIII. relate; That the Kings of Persia used a certain Oil with which they set Fire to Towns, and burned down their Gates, and that it was impossible to suppress the Flame of it even with Water, it being naturally able to withstand the Effects of that Liquid Element. This Oil was made of Petrol or Naptha. But if what Ct. Cnidius says of this Persian Oil appears fabulous to Scaliger, what would he have said of a certain Water mentioned by Leonard Fronsberger, which has such an extraordinary

† Scal. Ex. XIII. ‡ The Original has it: *Cooperta omnia sepeliantur in equi ventre per menses tres, in margine scriptum fuit, in equa facta ventre.*

Property, that if a Piece of Cannon be charged with it, it will project a Bullet to the Distance of 3000 Paces? He orders it to be compounded of 6 Parts of a *Saltpetrous Lixivium*, 2 Parts of *Oil of Sulphur*, 3 Parts of *Water of Sal Armoniac*, and 2 Parts of *Oleum* or *Balsamum Benedictum*. For my part, I can say nothing of this till I have made the Experiment. But upon the Whole, I do not apprehend that *Scaliger* had any great reason either to say or believe, that what he speaks of above is a Forgery and a Jugling Trick; for I am perfectly of Opinion, that it is not impossible to be true; and you may venture to think it a Fact, since I myself have found by Experience, that it is an easy matter to make *Compositions*, which will immediately catch Fire by sprinkling them over with Water, and break soon afterwards into a Flame, without the least Application of any Fire whatsoever to them. Now this Accension is purely owing to *Quick Lime*, to which you add certain Portions of hot and fiery Substances: I shall give you two of these *Compositions* of my own Invention, and which I have tried myself.

I.

Take of *Saltpeter* 10 lb; of *Sulphur Vivum* 6 lb; and of *Quick Lime* 20 lb.

II.

Take 6 lb of *Saltpeter*; 4 lb of *Sulphur*; lb ss of *Frankincense*; lb ss of *Linseed Oil*; ℥ iiij of *Oil of Petrol*; 8 lb of *Gun-powder*; 12 lb of *Quick Lime*; and one lb of the *Juice of Onions*.

The two following are from *Fronberger*.

I.

Take equal Portions of *Copperas-Water*, *Sulphur*, and *Oil of the Yolks of Eggs*, and putting them into a glazed Earthen Pan, fry them over a good Coal Fire, till they have acquired the Consistence of a Conserve; then add to them a fourth Part of *Wax*, and incorporate them well together: Preserve this *Composition* in an oiled Bladder, and stop it up closely with Wax so as no Air may have access to it. Our Author assures us, that this Mixture being exposed to the Wind in any open Place, it will take Fire, and that being wetted by Rain, it flames out, and that the Fire of it spoils, destroys and devours every thing within its Reach.

II.

Take *Quick Lime of Venice*, *Gum Arabic*, *Sulphur*, and *Linseed Oil*, equal Parts of each; incorporate them well together; and when you have a Mind to make Tryal of the Effects of this Mixture, sprinkle it over with a little Water, and it will be lighted, and dart out Flames on all Sides.

To these two I shall add a Third and Fourth, taken from *Jerome Ruffel* an *Italian*: The first of which is the *Composition* of a Stone, which being put into Water, or only moistened with Spittle immediately takes Fire. Take then *Quick Lime*, *Tutia* unprepared, *Saltpeter* several

veral times clarified (according to the last Method I gave you) and *Loadstone*, of each 1 Part; *Sulphur Vivum* and *Camphire*, of each 2 Parts: Put them into a narrow Earthen Pot, and this Pot into a large Crucible, and cover it with another of equal size; tye them fast together with Iron Wire, and lute the Junctures well up, that it may be impossible for any Air to insinuate itself; in short the Lute being thoroughly dry, you shall set these Crucibles into a Lime or a Brick *Kiln*, and as soon as the Lime or Brick is sufficiently burned, take your Crucibles out and break them, and you will have an hard Body like a Stone.

The other of this Author's Invention is thus; Take of *Oleum Benedictum* 1 lb, of *Linseed Oil* 3 lb, of *Oil of Eggs* 1 lb, of *Quick Lime* 8 lb: Mix and incorporate all these together according to Art. He assures that if any Thing whatsoever is smeared over with this it must infallibly be burned, nor can the *Fire* of it be suffocated by any means, particularly if never so little Rain falls upon it. There are those who attribute the Invention of this to *Alexander the Great*.

Those who would be farther informed of this Matter, may consult these Authors, who will give them all the Satisfaction they can wish. I shall only say that these *Compositions*, when well prepared and proved, may be applied to several Uses in *Pyrotechnics*; for besides the several purposes for which they were invented, they may serve to burn any thing in Water. Thus if you would burn a *Wooden Bridge*, you may at Low Water, send little Boats or Wooden Chests down the Stream towards it, well bound with Iron, and filled with *Hand Grenado's*, the Interstices between which may be filled up with one of these *Compositions*; taking care that these little Vessels or Chests be well shut up, and payed with a good Coat of Pitch, leaving only a very little Hole, through which the Water may insensibly drop amongst the said Mixture; and taking care to order the whole of it so that it be exactly of the same Specific Gravity with Water, for Reasons formerly given, that it may with the more ease be carried by the Stream to the *Bridge* you have a Design upon; which your Chests may catch hold on by Hooks or Graples artfully contrived for that Purpose, till the *Grenado's* take Fire by means of the *Composition* by which they are encompassed round, and by their usual Effects ruin and demolish the *Bridge* they stick at.

If your Curiosity inclines you to see these little Vessels swimming under the Surface of Water, you may find them in *Mersennus* in his *Coroll. II. Prop. 49* of his *Hydraulics*, and in *Book II. of his Art of Navigation*; as also in *Harmon Prop. 6. Advert. V.* From whence the Ingenious *Pyrobolist* may furnish himself with a great many fine Hints; and put them in practice in his Artificial Fireworks. For my part, I shall content myself with having pointed out to you the Places where you may find them.

C H A P. IX.

Of LIGHT BALLS.

IN the *First Part* of this *Book*, in *Chap. III.* and *Coroll. I.* we shewed you how to prepare *Recreative Light Balls*: I am now going to give you the *Military Sorts* of them, which are more dangerous and better adapted to do Execution in the the Occurrences of War. They are thus.

S O R T I.

Take equal Quantities of *Sulphur*, *Pitch*, *Rosin* and *Turpentine*, and melt them in a glazed Earthen, or Brass Pot: Then take a *Ball* either of Stone or Iron, whose Diameter is somewhat less than the *Calibre* of the *Mortar* or the *Cannon* it is to be shot from, and dip it all over in this Melted Stuff; which done, take it out and rowl it gently in *Corn Powder*. Then wrap it up in a Cotton Cloth, and immerge it again into your *Composition*, and taking it out again rowl it a second time in *Corn Powder*, and wrap it up again in a Cotton Cloth; in short, repeat this Operation till your *Ball* is of due Size: But you must take care that the Last Crust or Coat of your *Ball* be of *Corn Powder*. Being thus ordered fix it in your *Mortar* or *Cannon* naked as it is, without any farther Covering, and project it where you please. See *Fig. 155*, distinguished by Letters A and B.

S O R T II.

Take of clarified *Saltpeter* 1 Part, of *Sulphur* 1 Part, of *Orpiment* 1 Part, and of *Pitch* 1 Part, of *Colophone* $\frac{1}{2}$ Part, of *Varnish in Grains* or *Gum Juniper* 1 Part, and of *Frankincense* 1 Part. Reduce these Ingredients to a fine Meal, and incorporate them well together. Then take of *Turpentine* 1 Part, of *Mutton Suet* 1 Part, and of *Oil of Petrol* $\frac{1}{2}$ Part: Melt these in an Earthen or Copper Pan over a slow Fire, and as soon as they are melted, throw the above pulverized *Composition* into them, and mix them all together. In short, throw in a good quantity of *Flax*, *Hemp*, or *Cotton* amongst them, to give the whole such a Stiffness, as to bear making up in *Balls*; after which make it up in *Balls* accordingly, of what Sizes you please. These may be thrown amongst the Enemy when they are in the *Ditch*, or at the Foot of a *Rampart*, or preparing for an Assault; they will also serve to annoy those who are at work upon the *Galleries*, or who approach you by Sap to lodge themselves in the *Mines*: By their Brightness they will also

also shew you whatever is doing without your Walls; in short, these Nocturnal Lights will discover to you all the Enemy's Contrivances and Stratagems, to compass the Ruin of your Fellow-citizens and yourself. They moreover will not only serve to light you in the Night, but burn most outrageously and destroy every Thing that is within the Sphere of their Action.

If the Exigence of Affairs requires you to form very large *Balls* of the above Stuff, so as to fit the Orifices of *Mortars* or *Great Guns*; you may order them with the same Ease as we did those of the First Sort. These will be particularly useful, to throw into the Enemy's Lines, when they begin their Approaches afar off, or to any of their distant Works which are out of the reach of your Arm; that you may by them discover what is hid from you under the Veil of Night; and at the same time by illuminating all the circumadjacent Country, prevent the Besiegers Designs, or give you timely Notice of them. But I must caution you to reinforce these great *Balls* with strong Marline, or with a Network of Iron or Latten Wyre, for fear they should be dispersed in their Projection, or fly to pieces in the Air, instead of remaining whole and entire as they ought.

If these *Compositions* are too dear for you, you may use the following, which are cheaper, and to the full as effectual.

Take of *Sulphur* 10 lb, of common *Pitch* 4 lb, of *Colophone* 1 lb, of *Saltpeter* 2 lb, and of *Suet* or *Tallow* 2 lb. Melt all these, and add to them 1 lb of *Coal*, and mix the whole very well together over a Fire; then take it off, and throw 3 lb of *Meal Powder* into it; but not all at once, but at several Repetitions, continually stirring and mixing it with the other Ingredients: To this you shall add *Tow* as before, and make it up in Balls.

Or else take of *Colophone* 1 lb, of *Sulphur* 3 lb, of *Saltpeter* 1 lb, of *Coal* 1 lb, and a little *Crude Antimony*. Proceed with this as before: This was invented by *Fronspurger*, from whom *Brechtelius* borrowed it.

S O R T S III and IV.

These *Light Balls* may be so contrived as to be of a Mortal Nature, and by that means serve in a double Capacity, of dispersing Darknes, and destroying the Enemy. This was formerly put in Execution by the *Dutch* (as we are told by *Diegus Ufanus*, in *Treat. III.* of his *Artillery*, *Chap. XX.*) at the Famous and Memorable Siege of *Ostend*, from whence they threw *Light Balls* (prepared as we shall shew you) which did prodigious Mischiefe to the Besiegers. There is nothing difficult in the Preparation of them. You need only take an *Hand Grenado* armed on the Outside with *Musquet Balls*, or larger if you will; (so that the whole be nicely adjusted to the Calibre of the *Mortar* or *Gun*.) Having stopp'd up the Vent of your *Grenado* with a *Wooden Stopp*,

D d d d

you

you shall coat it over with Tow steeped in one of the aforesaid *Compositions* to the Thickness of two Fingers, and then pulling out the *Stopples* fill it with *Corn Powder*; and coat the Vent of it over as you did the rest of its Circumference, and rowl it in *Meal Powder*; in short, you shall secure the Coating upon it with Marline or Wyre, as we said before.

These *Balls* may be likewise prepared after this Manner: Take a certain quantity of *Iron Crackers* loaded with *Corn Powder* and *Leaden Bullets*; and with a Wyre, Cord, or Cat-gut, bind them together in such form that their Orifices being alternately disposed, they may appear like a *Radiant Sphere* or an *Hedge-Hog*: the Interstices between these Crackers shall be filled up with *Meal Powder* steeped and kneaded in Brandy, in which has been previously dissolved some common Glue, or any sort of Gum. In doing this you must take care to make it into a perfect Sphere. Then giving it a Coat of Cotton Cloth, dry it in the Sun, or in a Fire-Pan; and proceed with it according to the Method we have already laid down. See more concerning these *Balls*; in *Diegus Ufanus Treat.* III. of his *Artill. Chap.* XX and XXI, and in *Hanzelet's Artill. Page* 187 and 211, In *Brechtelius Part* II. of his *Artill. Chap.* I and IV; and *Fronsberger's Artill. Part.* II. *Page* 194 and 196. The last of these Authors, in the Place I have now quoted, will instruct you in the Preparation of a *Ball* which not only burns in a frightful manner, but also serves instead of *Crow-Feet*. This is the order he observes. Take a *Wooden Ball* and arm it all round with sharp *Iron Spikes*, taking care that the Points of them which are driven into the Wood tend all to the Center of the said *Ball*, and that their outward Points be about one or two Inches from one another, just after the manner of a sleeping *Hedge-Hog*. Being thus ordered, the Interstices between the Spikes, shall be filled up with Tow steeped in one of our *Liquid Compositions*, but not so as to cover the Points of them, which must rise out to the Height of half a Finger's Breadth above the Tow. For any thing else relating to this you may consult the Author himself. Besides the *Pyrobolic* Writers I just now mentioned, you may upon this Subject turn over *Jerome Catanenus's Examination of Artill. Page* 37. *Jerome Russel's Precepts of the modern Arts of War, Page* 11, 32 and 33. And *Eugenius Gentilinus's Instructions in Artillery, Chap.* LX. and several others.



C H A P. X.

Of Smoke Balls, which the Germans call Dampf and Blend Kugelen.

WE have oftentimes recourse to Darkneſs in the Occurrences of *War*, as well as in the Perpetration of ſeveral other Matters; I do not here mean the Gloomineſs and Natural Darkneſs of Night; but ſuch as is Artificial, and which, according to ſome *Rules* of our *Art*, is cauſed to remain for ſome time in narrow Places; whether it be that the Beſieged would blind the Enemy in the miſt of an Attack; or whether the Beſiegers, to favour or facilitate their Affaults, would overwhelm the Beſieged with a thick offensive Smoke, and by that means take them like Fiſh in troubled Waters. To this Purpoſe we have a Way of preparing *Balls* which during their Combution caſt forth a Noiſome Smoke, and that in ſuch Abundance, that it is impoſſible to bear it. You are to proceed thus: Take of common *Stone Pitch* 4 lb; of *Tar* 2 lb, of *Colophone* 6 lb, of *Sulphur* 8 lb, and of *Saltpeter* 36 lb: Melt all theſe Ingredients together over a Fire; and then add to them 10 lb of *Coal*; 6 lb of the Sawduſt of *Pine* or *Fir*, and 2 lb of *Crude Antimony*; incorporate all theſe together; which done, throw amongſt them a ſufficient Quantity of *Flax* or *Hemp*: Your *Tow* being ſteeped a due time, and having imbibed enough of this *Liquified Compoſition*, make it up in *Balls* either to be thrown by Hand, or ſhot from any Machine. As to any thing elſe relating to this Matter, you are to obſerve the *Rules* we have already laid down in the Preparation of *Light-Balls*.

This is the right Method of introducing Night at Mid-day, of intercepting the Sun-Beams, and depriving the Adverſary of the Benefit of Eye-Sight: And the Practice of this is the more lawful, in aſmuch as it is an Imitation of *Nature*, and may with Honour be executed in a righteous *War*. But I baniſh all unlawful Practices from the *Chriſtian Arts* of *War*; and eſteem thoſe *Arts* as infamous, which are founded upon † Charms, Sorcery, and the Invocation of unclean Spirits, together with ſeveral other abominable Superſtitious which muſt be hateful to God, odious to Men, and undeſerving the Title of *Art*. It is with Horror that I reflect upon the Falcinations of the *Moscovites*, *Tartars*, and even of our *Coffacks*. But not to dwell on the damnable Abominations, and horrid Impieties, perpetrated by thoſe Wretches with the Aſſiſtance of Infernal Powers; I ſhall only curſorily ſay that they are moſt deeply

† Here we muſt allow for the Prejudice and Superſtition of our Author's Religion.

versed in *Sorcery*, and all the *Arts of Hell*, and can raise Fogs, Storms, and darken the Light of the Day by means of thick Mists to such a degree, as to prevent you from seeing such Things as are nearest to you: In short, one would think that they had been perpetual Students under *Zoroaster the Bactrian*; or that they had been bred up in the very Recesses of *Pluto* himself: But as these Monsters are forsaken of God, and alienated from his Grace, when they resort to this *Diabolical Science* for a successful Issue to their *Wars*, they cease to be under his Divine Protection, and meet with Events suitable to their Wickedness. I could produce many Examples recorded in our Histories to corroborate the Truth of what I have here said; but shall content myself with giving a succinct Narration of a prodigious and miraculous Victory which God was pleased to give us, over † 800,000 *Crim and Precopian Tartars*, near a small Town in *Podolia* called *Ochmatow*, in the Year 1644. These *Barbarians* then by their Diabolical Incantations, suddenly raised so thick and frightful a Fog, that we really thought *Nature* had inverted the common Order of Things, and had turned the Day into Night. By this means our *Army* (which was small in Number but great in Heart, under the Conduct of that Thunder-bolt of War, *Stanislaus Koniecpolski*, formerly the King of *Poland's* General,) was wrapped in Mist, and wandered up and down the Country, and marched several Miles, before we could overtake, or fall in with those Miscreants, to give them the Chastisement due to their Demerits, and to take Vengeance on them for the Evils they had created us. But we found that the Confidence we had reposed in Heaven did not prove ineffectual; for no sooner did we get Sight of the Villains, than the Sun entirely dispersed the Fog, (under the Covert of which they had committed the most horrid Barbarities;) so that enjoying compleat Day-light again, we soon experienced that Heaven had not abandoned us in our Extremities: In short, to say that in few Words, which many have related with Prolixity: I was present, I was an Eye-witness of the Fact, and our God discomfited them.

C H A P. XI.

Of POISONED BALLS.

OF the many laudable *Military Laws and Regulations*, which were established amongst the ancient *Germans*; and which they obliged their *Pyrotechnicians* to bind themselves by an Oath to observe; the fol-

† In the Book it is 80,000, which is more likely, but the *Table of Errata* will have it 800,000.

lowing were none of the last nor most inconsiderable (see *Brechtelius Part II. and Chap. II.*) namely; That they should never prepare any *Fire-Works* that should be any ways hurtful to any Persons or Things: That they should not fire any Cannon in the Night-time: That they should not clandestinely hide Fires in secret Places: But above all, That they should not prepare any *Poisoned Balls*, nor use any sort of Venom in their *Compositions*, or upon any other Account whatsoever that might affect the Life of Man; for the first Professors of our *Art* looked upon all such Actions to be as heinous in themselves, as they were unworthy of a brave Man and a true Soldier; and scorned to destroy their Enemies, by such ungenerous and unmanly Stratagems, since they might annoy them a thousand Ways in honourable open Combat: Therefore since all Laws, Divine and Human, do in the strictest manner forbid us in our Civil Capacity to have recourse to such inhuman Artifices; and since they have ordained corporal Punishments to be inflicted on those, who to gratify their Lusts, make any hurtful Use of Poison, Charms, Incantations, &c. how much more ought these Laws to be observed, and how much more are such Practices to be shunned in our Military Capacity? Which is not a State of unbridled Licence, or infamous unruly Diffoluteness; but on the contrary, a State of the strictest Honour, the most unshaken Fortitude, the most constant Magnanimity, the most sincere Probity; in short, the State of *War* ought to be as it were a Theatre of all Sorts of Virtue. As for private Arms, which are no other than the mere Productions of *Art*, I do not in the least disapprove of them, nor will I rank them among such Things as are unlawful; for we have the Authority of very great Captains who have put them in practice, and greatly commended them, upon which Account I shall venture to shew you something farther of them in this little Work: But I will by no means admit *Poisoned Balls* into the Class of *Warlike Inventions*, nor allow the Use of them to a *Soldier*, who as he is a Man of Generosity, and much more as he is a Christian, ought to abhor the very Thoughts of murdering his Neighbour with an invenomed Weapon. Sure, the fertile Malice, and the continual Experience and Exercise of Mankind in successive Bloody Wars, ever since the *Halcyon Days* of the Golden Age, have furnished us with Arms sufficient either to offend our Adversaries, or defend ourselves against them! Let us not therefore in shedding the Blood of our Brethren indanger our own Souls.

But after all it must be allowed by what we can gather from the Historical Records of the Wars in the earliest Ages of the World, that these *Poisoned Balls* need not appear so heinous to us; and we find that the most scrupulous Consciences did not boggle at the Use of invenomed Weapons in former Days; nor need the strictest Christian refuse or reject them now, provided that he does not use them in a War against those of his own Faith, but reserves them for *Tartars*, *Turks*, and

other *Infidels*, who are sworn Enemies both to the Christian Name and Religion; for those we may safely exclude from the Number of our Neighbours. Now these *Balls*, are such as in their bursting or burning, taint the Air to a degree of Mortality; for we are taught by Experience, and assured by the Learned, that the *Poisonous Suffumigations* or *Effluvia* of such Things as you must use for these *Balls*, destroy the Health of Man, strike at the very Principles of Life, and consequently extinguish the Animal Spirits which keep the Soul confined to the Body. But by the way, you must believe, that such Pestilential Vapours cannot be very effectual, except in some close covered Place; for I doubt of the Service of this Contrivance in any open Place, such as a Town or Fort which lies exposed to the Wind and Flux of the *Air*: Upon the whole, I can say nothing certain upon this Head; and can only guess at what might be the Effects of it, from what little Knowledge I have in *Natural Philosophy*; but a few Experiments will inform you of every thing you can desire to know concerning it.

One Evil generally draws a Thousand after it: Thus Mankind did not think the bare Invention of *Bows* and *Arrows* sufficient; (which the Ancients held to be of divine Contrivance, and accordingly *Diodorus Sic.* ascribes them to *Apollo*, and *Pliny* to *Scytbes* the Son of *Jupiter*;) I say they did not think their *Arrows* simply of themselves, to be sufficiently dangerous and hurtful, but they must likewise be steeped in Poison as well as their other Arms, to render the Wounds of them the more certainly mortal. We have the Testimony of several Authors to prove the Antiquity and Use of this Contrivance; and amongst the Rest in *Pliny Lib. XII. Cap. LIII*, where he treats of the *Scythians*; in *Paulus Aegin. Lib. VI. Cap. LXXXVIII*, where he speaks of the *Dacians* and *Dalmatians*; *Theophrastus, Lib. Plant. IX. Cap. XV*, where he discourses of the *Æthiopian* and *Barbarian Wars* in general; *Dioscorides Lib. VI. Cap. XX*. In short, *Virgil* in his *Æneid Lib. IX.* speaks thus:

Ungere tela manu, ferrumque armare veneno.

In English:

In Darts invenom'd, and in Poison skill'd.

Dryden.

And in *Lib. X.*

Vulnera dirigere & calamos armare veneno.

In English:

Directing Ointed Arrows from afar;
And Death with Poison arm'd.

Dryden.

And

And in *Lib. XII.*

*Non secus ac nervo per nubem impulsa sagitta,
Armatam sævi Partibus quam felle veneni,
Partibus sive Cydon telum immedicabile torfit.*

In *English* :

————— by far more slow
Springs the swift Arrow from the *Partbian* Bow,
Or *Cydon* Eugh when traversing the Skies,
And drench'd in pois'nous Juice the sure Destruction flies. *Dryden.*

Ovid de Trif. Lib. III.

And *Silius* also *Lib. I.*

Homer speaks thus in his *Odyssey. I.*

Φάρμακον ἀνδρὸφόρον διζήμιδος, ὄφρα οἱ ἐν
ἰὲς χεῖρας

In *Latin* :

Pharmacum, mortiferum quærens, ut ei esset unde sagittas oblineret.

In *English* :

Seeking a deadly Drug wherewith t' infect his Darts.

Thus by the Hint we have taken from the Practice of former Ages, Men dye a Triple Death ; for the *Ball* pierces the *Body*, the *Poison* coagulates our *Blood*, and the *Fire* burns us up.

Certain it is, that the first Inventor of our *Gun-powder* is highly blameable, for having introduced an Invention of shooting *Bullets* by the means of *Fire* ; but those are still worse who added *Poison* to those *Balls*, as if simply of themselves they were not sufficiently mortal. From hence are derived our *Poisoned Balls* in Use amongst *Pyroballists*, and hence the *Venomous Bullets* in Vogue amongst the Modern *Soldiery*. But before we enter in earnest upon this Subject, I must beg your Attention to what *Joseph Quercetan* saith, who was a very famous Physician, (*viz.*)

† *That we may not answer this Question absurdly, I shall ingenuously confess, that Lead simply considered as to its own Nature, has no infectious Effect upon Wounds, nor never has, except it be outwardly infected by any poisonous Tincture, and that it can be infected no-body will deny: For I*

† *Jof. Quercet. in Libello Sclopetario.*

believe every one will allow, (what is generally received amongst Philosophers;) that though Lead is very heavy and gross with respect to other Metals, yet its Contexture is very porous and spongy, which is owing to its being compounded of impure and combustible Sulphur; and of much feculent and drossy Mercury, upon which account it is so soft and easily melted, and copiously imbibes any Liquid: If this last Quality be attributed to Iron, which is harder and not so porous; sure no one can doubt that Lead will much more readily admit any Infection; and that this is true we have the Testimony of many great Authors to evince.

And a little lower. Nor do those argue to the purpose; who deny that Lead, because divested of its Crudity and Grossness by being purified, cannot admit any strange Body into it: Indeed Nature informs us, and Experience shews, that all Metals purified by Fire, are disincumbered of their Dross; and are much refined after an Igneous Operation; for by this Method are Copper, Tin, and even Iron refined; which by being melted by Fire is disunited from all its Drossy Particles, and the pure Substance of it, which we call Steel, remains collected together, as may be proved from 4 Meteor. Cap. 6. of Aristotle. Now though it be the Nature of these Metals, to be refined by Fire; (as we have said above) and by Fusion to discharge all their Dross; yet that does not prevent them from imbibing any foreign Substance. And who can dispute but that Steel, which we may rank amongst the most solid Metals, may be mixed and tempered with a Substance quite foreign to itself? Who will affirm that a Mixture of Vinegar, Soot, Water of Mouse-ear, and of Earth-worms, mixed with the Juice of Radishes, is in any respect of an Ironish Substance? Yet if Iron be frequently dipped and quenched in that Liquor, it will acquire such a Hardness as is not to be believed but by those who have made the Experiment. On the other Hand, if it be often quenched in the Juice of Marsh-Mallows, Soap, or Hemlock, it will be mollified. It also happens to Tin and Lead, that being melted and often cooled in the Juice of the Squilla or Sea Onion they are affected in such a manner, that the first loses its noisy or ringing Quality, and the latter its Blackness and Softness, which could not be except they retained something of the Spirit and Property of the Liquor in which they are tempered. It is therefore plain, that how greatly soever Metals may be purified, and purged of their Dross, they are capable of imbibing a Substance of a different Nature from their own. But it would be folly to say that the Mixture of Metallic Spirits which are of the same Genus or Kind, cannot be more easily effected than this: For we see that Copper is tinged and turned Yellow by the Spirit of Calamine and of Tutia: and on the other hand it is whitened by the Spirit of Arsenic, of Orpiment, &c. From whence we may safely conclude, That if Metals (of which Bullets are commonly made, and particularly Lead,) should be infected by any Spirituous Substance inclining to their own Nature (which may be prepared of so many sorts of Mercurial, Fœtid and Deadly Waters, to which are usually added the Juice of Aconitum or Wolf-

Wolf-bane, of Napellus, of the Squilla or Sea-Onion, of Eugh, of Smal-lage or Crow-foot, and such like Simples, and venomous Beasts, which are of noxious Effect upon our Nature) I say, being tainted by such like Compositions, the Wounds they make will be so complicated by means of the Venom, that except immediate Remedies be applied they must be Mortal. For we have at this Day amongst us many Mixtures which are so Venomous and Pestiferous, that if the Point of an Arrow be but steeped a little in them, and it wounds any Body slightly, or only passes through any particular Member with a sudden Celerity, and makes no stay in the wounded Part, the Poison is so subtile that it at once diffuses itself over the whole Mass of Blood, infects the most Noble Parts, and instantly kills the Person.

Speaking farther on this Subject. From hence we will conclude that Balls may be infected with Venom, not by pouring any into an Hole made to receive it, as some would have it; but by immersing the Bullets and repeatedly quenching them in some of these Mercurial Waters or Deadly Juices; by which means they may be corrupted and infected, and (such is the Subtlety of these Drugs!) invenom the Wounds they make, though they should with the greatest Velocity pierce through the Body. This has been experienced upon Animals, which I shall account for in my Book of Antidotes I just now mentioned. But by the way I must observe, that if a Ball passes very swiftly through a Body, it cannot so well or effectually communicate its Venom; but it most frequently happens that Bullets lodge in the Wounds, and remain there some time before the Surgeon can take them out, which oftentimes is not to be done at all.

Who then can doubt, but that the Ball will work its Deadly Effects during the time it thus remains in the Body? (The more Spirituous and Subtile they are, as I shewed above, the more sudden are their Effects:.) And its Malignant Effluvia being conveyed through the Veins, Arteries, and Nerves, they infect the Natural, Vital, and Animal Spirits, and by being blended with them, and by the natural Contest which arises between them, in which the former always get the better, the Life of the Person is extinguished, which purely consisted in the lively proper Action of the Spirits. That Poisons are the most pernicious when they are the most subtile may be gathered from the Bites of Vipers and other venomous Creatures.

This is all that our Author says of the Method of poisoning *Metallic Bullets*, and their manner of affecting the Human Body.

Those then who would prepare *Poisoned Balls* may observe the Rules laid down by former *Pyrobolists*, or these of our Invention. Take of *Wolf-bane*, or *Wolf-wort*, which the *Italians* call *Luparia*, and the *Germans* *Wulffvurts*; of *Napellus*, whose Root is in form of a Net; (This is a most dangerous Poison;) press out the Juice of it, but take care not to touch it with your Naked Hand: The Juice of it being expressed, put it into a capacious Earthen Pan, and expose it to the Sun in the

F f f f

Month

Month of *July*, for the space of a whole Day; that is, as long as the Sun has any powerful Influence upon it; this done, put it in some warm close Place, which must have no *Onions* or *Garlic* near it, or any other strong-scented Thing, for it may be thereby deprived of much of its Strength and Virtue: On the Morrow expose it again to the Sun as you did before, and so continue to do for the space of a whole Month: And you will have a thick, foul, venomous Substance like an Ointment. But you must be careful to Air the Place where you lock up your Pan in the Night, for fear the malignant *Effluvia* of this Poison should be conveyed through the Nostrils into the Head, and be attended with Consequences prejudicial to your Health.

Take moreover 3 or 4 of the rankest sort of Toads, of such particularly as are bred in the most shady and cold Places; for there they acquire the most virulent Venom. These shall be put into a Brass Vessel like an Alembic, where they may have Room to sprawl about; which Vessel shall have a Head that nicely fits it, with a Handle at Top of it to lift it on or off; upon one Side of your Vessel you shall have a little round Trough, with a Slit over it, which shall be filled with *Oil of Scorpions*. Cover the whole up closely, and let the Pipe or Spout of your Alembic be received in a Glass Phial, which must be set in a Basin of cold Water. This done, light a gentle Fire all round it, at the distance of one or two Palms, that it may heat by slow degrees; and the Toads, as soon as they are affected by the Warmth, will immediately spew up all their Venom. Thus by Vomiting and Sweating they must of course become thirsty, and will accordingly drink of the Oil contained in the little Trough to quench their Thirst, and will soon after bring it up again, and it will in the end be distilled into the Glass Phial aforesaid. The Fire shall be kept up in an uniform Heat for four Hours; then leave your Operation unfinished till next Day, and wait for a Breeze of Wind before you take off the Head of your Alembic; and keeping to the Windward of it, at the distance of a few Paces lift off the Head with a long Pole, by running it into the Handle above-mentioned; and leave your Vessel open for 4 or 5 Hours: In short, the noxious *Effluvia* being by that time dispersed you may safely approach it, to take away your Phial. So much for the Preparation of this Poison, now for the Use of it. Sprinkle over the *Composition* of your *Fire-Balls* with this Deadly Extraction, together with the Juices of the Herbs I am going to mention, and charge your *Ball* according to the usual Way.

You may then add to this: The *Juices* of *Anemony*, of *Torch-weed*, of *Hemlock*, of *Henbane*, of *Mandrake Apples*, of *Mandrake*, of *Napellus* White and Blue, *Monks-bodd*, *Past-flower*, *Butter-flower*, *Poisonous Nightshade*, *Sea-Onion*, and several other Simples of this Nature.

The following Things pulverized may do very well, (*viz.*) *Mercury Sublimate*, *White Arsenic*, *Orpiment*, *Cinnabar*, *Minium*, *Litharge*, to which may be added the *Menstrua* of *Barren Women*, the *Brains* of *Rats*,
Cats,

Cats, Bears; the Foam of Mad-Dogs, the Blood of Bats, Oil in which has been previously drowned a good quantity of House-Spiders, of Quick-silver, Diagrede, Coloquintida, Euphorbium, one and the other Hellebore, of Thymelea, Garden-Spurge, Nux Vomica, and several other such Things as are of noxious Efficacy.

You may also prepare a *Gun-powder*, which will infect the *Air*, and suddenly kill those who draw in the *Smoke* of it; after this manner: Take a *Toad* and smother it in *Salt-peter*, and bury it under an Horse *Dung-hill* for a Fortnight; then take it out, and proportion it with *Sulphur* and *Coal* as we formerly ordered.

Or you may melt *Salt-peter* over a *Fire*, and throw a good parcel of *House-Spiders* into it alive, so that being suffocated they may discharge all their *Venom* into it; you may also powder your *Salt-peter* over with a little *Arsenic*; after having incorporated a good quantity of that *Drug* with it: Then make your *Gun-powder* with it after the usual manner.

OBSERVATION I.

I believe it will be best, if to the *Compositions* we have given for *Smoke Balls*, you add the *Juices* of the *Herbs* abovementioned, with their *Leaves* and *Roots* about half withered; together with the several other *Poisonous Things* we just now enumerated; and make them into *Balls* as before. You might also add the outward *Bark* of *Birch*; for all such *Ingredients* produce a thick suffocating *Smoke*, and particularly the damp *Leaves* and *Roots* of the above *Herbs*; add to which, that the *Smoke* they emit being moist and heavy, it flags near the *Surface* of the *Ground*, and does not spring up to any great *Height* into the *Air*; but smothers and creeps along beneath, and spreads through every where, where it can have *Admittance*: And upon this Account, the best *Opportunity* you can have for putting these *Balls* in Execution, is when the *Heavens* are clouded over, and misty; during a thick *Fog*, or in great *Rains*, or when it snows, and in gloomy heavy *Nights*; for the *Air* is at those times impregnated with gross *Vapours*, which are † impenetrable by the *Smoke*, and copiously interspersed with *Substances* heavier than itself, which suppress the *Fumes* of your *Ball*; which would tend upwards in serene clear *Weather*.

OBSERVATION II.

You may arm these *Balls* with *Crackers*, to guard them from the Attempts of the *Enemy*.

† It is not owing to the Impenetrability of *Vapours*, but the *Lightness* of the *Air* in foul *Weather* that *Smoke* does not rise; for at that *Time* the *Smoke*, as soon as it is rais'd or exploded from the *smoking Body* into the *Air*, falls down again by reason that it is specifically heavier than *Air*; whereas in fair *Weather* when the *Air* is heaviest, and consequently denser near the *Ground*, the *Smoke* being than lighter than *Air*, rises upright by the *Laws* of *Hydrostatics*.

OBSERVATION III.

You must be careful, that what you prepare for the Ruin of your Enemies, does not turn to your own Destruction; and that instead of conveying Death into the Adversary's Quarters, you be not suddenly intercepted by it yourself, and overwhelmed before you know where you are. To prevent these Self-dangerous Inconveniencies, you shall crust your *Ball* over with common *Gun-powder* uninfected, and then coat it over with *Tow*: Or else putting these poisonous *Compositions* into Bags, as is done in the Case of *Fire-Balls*, you shall fill the Fuzes of them with a common *Slow Composition*.

The rest I shall leave to the Discretion and Diligence of the expert *Pyroballist*; and to say the Truth, none of us stand in need of Instruction in Mischiefs; for we naturally have a strong Propension to it, and are commonly industrious in the Perpetration of it. I shall now close up this *Chapter* with conjuring you, never to apply these *Balls* after such a manner as to need Repentance after it, or in any respect to wound your own Conscience; always keeping in Mind, that the Love of our Neighbour is inseparable from the Love of God; and that we have a righteous Judge who wants no Witness to our Actions, and who will most certainly deal with us according to the Evil of our Ways.

C H A P. XII.

Of STINK-BALLS.

THESE *Stink-Balls* seem to be pretty nearly related to the *Balls* we have just now treated of; but the Use of them is much more lawful, and much less pernicious; for these only molest the Enemy by their Fætid Vapours, wrap them up in artificial Mist; offend both the Nose and Head, by their extraordinary Nauseousness; and pain the Eyes by the Sharpness of their Smoke, without any immediate Infection. They are in the main prepared just like other *Artificial Balls*, and therefore I shall give you the Construction of them in few Words. Take 10 lb of common *Skip Pitch*; 6 lb of *Tar*; 20 lb of *Saltpeter*; 8 lb of *Sulphur*; 4 lb of *Colophone*. Melt all these over a slow Fire in an Earthen Pot: And being melted, throw into them 2 lb of *Coal*, 6 lb of the Rasings or Parings of *Horse's* or *Mule's Hoof*; 3 lb of *Asa Fætida*; one lb of *Sagapenum*, which the *Latins* call *Sacopenium Putidum*; and 1 lb of *Spatula Fætida*, or *stinking Gladwin*: Incorporate all the above *Ingredients* well together; and add to them as much *Flax* or *Hemp* as is sufficient

cient to absorb them: Then whilst the *Tow* is warm, make it into *Balls*; in fine, you shall observe the very same Order with these, as we have in general directed for *Light-Balls*, *Smoke-Balls*, and *Poisoned Balls*.

C O R O L L A R Y.

What Man is there who knows not that the Air we breathe may be dangerously tainted; and that contagious Distempers are commonly generated by the Corruption of that Element? Thus a besieged Place being no other than a Theatre of all the Evils Mankind can be afflicted by; it is amongst other Inconveniences subject to pestilential Vapours, arising from the stinking *Effluvia* of Carrion, the Putrefaction of rotten Carcasses, and other Filths which they cannot remove out of the Town. I shall not here undertake a Rehearsal of the many Examples of Sieges, in which the Besieged have been more abundantly cut off by Pestilence than by Steel or by Fire: But to come to the Point in hand, I say, that the corrupted Air of Besieged Places may not only proceed from Natural Causes, but may also be introduced by the Artifices of the Besiegers. The putrid Stinks within are those of the unfavourable rotten Breaths of the *Famished* and *Over-fatigued*, the corrupted Bodies of the *Slain*; Dunghills, and many other Things from whence unwholesome Vapours are exhaled. Now the Besiegers may add to the Natural Infection of the Town, or even originally cause it by means of several Sorts of Poisoned Infectious *Balls*; or by throwing with the Ancient Machines (if you will admit them again into Service) the Putrid Carcasses of Soldiers, or any sort of Carrion; together with great Tubs full of the Emptyings of Privies, and the like, which may be tossed into the Besieged Place. History will inform you of many such like Practices amongst the Ancient *Romans*, and the other Warlike Nations of their Time: But not to look so far backwards, we have a very modern Instance of this in the Chronicles of the City of *Liege*, where we met with this Remark (*viz.*) *The Liegeois vigorously assaulted the Castle of Argenteal, throwing great Stones into it with Balistæ, together with Earthen Vessels full of melted Metal, Red-hot Iron, and Excrements in abundance.*

From hence we may draw these Conclusions: *First*, that the Air of a Town may be terribly infected; and corrupted to that degree as to oblige the Besieged to a more speedy Surrender, or at least urge them to a Parly sooner than they designed.

Secondly (which is well worth our Observation) That by the Help of the Antique Machines, you may not only sling the Dead Carcasses of Men and Horses, together with large Vessels full of Fiery, Flaming, or Scalding Matter; but also ponderous round Stones, vast Splinters of Rocks, and other Bodies of immense Weight. Amongst the many Testimonies which might be brought to corroborate this Fact, I shall give you only one, which I have taken from *Paul. Emil.* in his History

of the Siege of † *Ptolemais* in *Palestine* by *Philip* King of *France* and *Henry* King of *England* (namely) they broke in the Roofs of the Houses with great Stones shot from their ‡ *Tollenons*, which were the Bane of the Inhabitants.

Silius also mentions them in *Lib. I.*

*Phocais effundit vastos Balista Molares,
Atque eadem ingentis mutato pondere teli
Ferratam excutiens ornum media agmina rupit.*

In *English*:

————— Then from contracted Strings,
Stones of vast Bulk the *Phocæan* Engine flings,
Or changing Weight whole Trees with Iron bound,
Ejects, that breaking through, the Ranks confound.

Ross.

Judge now of their Weight by their strange and frightful Execution. We moreover find in the *Annals* of *Spain* (according to *Lipfius*) a Story of a Young Man called *Pelagius*, who was a Person of great Modesty, and being earnestly sollicitated by a Beastly King to commit that Crime with him which will not bear to be named, he accidentally struck him whilst the Brute was carefing him; upon which the Infamous Monster of a Prince ordered him to be put upon a *Balista*, and thrown over the River *Betys* across the Rocks. But I shall speak more at large of this in its proper Place; where (as I have said before) I shall give you the *Figures* of the Ancient Machines with all the Accuracy the Remarks I have made upon the Accounts given of them could suggest to me; in which I have gone so far as even to make Models of them with my own Hands, to try their Effects, and to see whether Authors have had a due regard to Truth in what they have related of them. I only mention them here, to remind you that the Besieged may expeditiously and conveniently gall the Enemy, with putrified Carcasses and an infinite Number of Vessels of all Sorts of Figure filled with Venomous or Smoky Compositions, and all other *Pyroboical Projectiles*, which we shall touch upon in the following *Book*, and particularly such as are ordinarily used in the Defence of Places. Let Men of Sense and sound Judgment consider a little upon these Things; and if they can convince me that I am out of the Way, after all I have said and quoted upon this Head; I shall readily submit to their reasonable Demonstrations: But as I apprehend myself to be in no danger of such Conviction, I shall to the latest Hour of my Breath regret the Inactive State of some of the *Antique Machines*.

† This Town is now called *St. John D'Acra*. ‡ These were the same with *Balista*.

C H A P. XIII.

Of a Ball, which Fire-Workers call a Death's Head.

TAKE a perfectly round *Ball*, of Iron or any other Metal, of such Fig. 156. Diameter as conveniently to fit the Calibre of the Piece of Ordnance you intend to use. The Body of it must be hollowed out Cylindrically, which it may be to the Depth of $\frac{2}{3}$; and the Breadth of $\frac{1}{3}$ of its Diameter; The Sides of it shall likewise be bored in several Places, all which Borings shall tend towards the Hollow Cylinder in the Middle, but shall not center in it quite, and shall only correspond with it by fine Holes or Fuzes. These little Fuzes shall be filled with fine *Meal Powder*; and the large Cavities shall be filled with *Corn Powder* and *Leaden Shot*, and Wadded well with *Paper* or *Tow*.

The great Hollow in the Middle shall be filled with *Meal Powder*, to which shall be added $\frac{1}{3}$ of *Coal*, and shall be sprinkled over with *Brandy* or *Oil of Petrol*; or else it may be filled with one of the *Compositions* I have given for the Fuzes of *Grenado's*. In short, the whole shall be coated with a Tarr'd Cloth, leaving only the Vent of it open. When you Fire this *Ball* you shall let the Orifice of it rest immediately upon the *Powder* in the Piece, without the Interposition of any Wadd between them: See Fig. 156.

Observe here that these *Balls* may be made of Wood also; but in this Case you must thrust such *Crackers* as you see in D, Fig. 151, into all Fig. 151. the Cavities but that in the Middle; in a word, it shall be reinforced with an Iron Bandage, to prevent its breaking to pieces at the time of its Projection, and so prove of no Effect.

C H A P. XIV.

Of a Ball commonly called the Pyrobolist's Valet or Attendant.

THE *Ball* which you see represented under Fig. 157, has got the Fig. 157. Name of the *Fire-worker's Servant*, from its constant readiness to do Service, in which it differs from all the rest. Now this gentle Servant is very simple in Nature, and easily governed and constructed. You need only take a Wooden Cylinder whose Diameter is equal to the *Calibre* of your Piece of Ordnance: Its whole Height shall be 3 of its Diameter, and one End of it shall terminate in a Multilateral Pyramid;

mid; which Pyramidal Part of it shall be another Diameter. The Sides of it then shall be bored all round with Holes of the Diameter of two Fingers Breadth, each of which shall correspond with that in the Middle of it. Into these Holes you shall thrust such *Crackers* as we just now mentioned (supposing it to be made of Wood.) The Cavity in the Middle shall be filled as we directed above for the Preceding *Ball*. Its Point shall be armed with Steel, that it may stick fast into any thing it falls upon or strikes against. Farthermore, it shall be reinforced with three Iron Rings, (*viz.*) one round the Top of it, one round the Middle, and a third round the Foot of its Pyramid; By this means it will be able to withstand the Shock of the Flash: As to any thing farther relating to this, it must be ordered just like the Preceding *Ball*.

C H A P. XV.

Of the Pyrotechnic Manipulus or Bundle.

IT often happens that you are so suddenly surprized and reduced to such Extremities, that you have not time to prepare these Artificial *Balls* in due Form: And in such Exigents this *Manipulus* may be resorted to, which is no other than a Bundle of *Iron or Copper Crackers* of the same you see represented Numb. 151, under the Letters F, G, and I; (no matter whether they be Triple, Double, or Single) they must be charged with *Corn Powder* and *Leaden Balls*, and bound firmly together with Wyre or Cat-gut, so that they may not be torn asunder by the Violence of the Flash of the Gun, but remain collected in a Body, and perform their Effects together. They shall be primed with one of the *slow Compositions* we formerly gave. In short, these *Bundles* may be of various Sizes, according to the Calibres of the *Mortars* or *Guns* they are to be projected from: They shall be put naked into the Piece, and rest immediately upon the *Powder* in it.

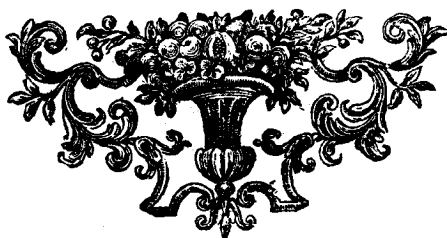

C H A P. XVI.

Of certain Pyrotechnic Balls which may be privately hid, and so ordered as to perform their Effects at certain Prefixed Periods of Time.

WE have elsewhere acquainted you that the Old *German Captains* detested the Use of clandestine Fires, and banished them from their *Arts of War*, as unjust and ungenerous Inventions, and accordingly forbad their *Pyrobolists* and *Fire-Workers* to prepare any of them: But notwithstanding this laudable *Injunction*, we find in *History* that these *Fires* were put in Execution even when *that* and several others of the same Tendency were in their Prime, and full Force: In our Age indeed it seems as if these and several other old Inventions must make their *Exit*, and give Place to new ones formerly unknown; and accordingly these *Balls* are upon the Point of Expiration; so that were they not recorded in our Writings, the very Remembrance of them would be blotted out in a very few Years more. Now since our Forefathers found them of Use in their Days, (however unfair they might deem them) why should they not be of some Service to us as well as to them? A good Head and a little Diligence, would turn them to some Account at proper Times and Places. I find several ways of constructing them both as to Form and Size, according to the Exigence or Nature of the Affairs we would employ them in: For those which are to be hid in Houses, Closets, Barns, &c. must be of one sort; those which are lodged in *Powder Magazines* and *Arsenals* into which we have free Access must be of another kind; and those which are conveyed into Waggons, Trunks, Casks, or any Baggage which is going into the Enemy's Forts and Garrisons must be of a Third Species. I shall only give an Example of them in three *Balls* of different Sorts; the First of which, distinguished by the Letter A, in *Figure 159*, bears an exact Resemblance to a common *Fire-Ball*; and does not seem to differ from it in any particular excepting its *Match*, which is wound round it (provided it is upon any Plane) in Spiral Folds. This *Match* must be of that sort which neither smokes nor yields an offensive Scent, the Preparation of which we taught you in *Book II. Chap. XXVII*. One of the Ends of this *Match* is stuck into the *Vent* of the *Ball*, and the other which is lighted is coiled round it, so as to have its Revolutions at a convenient Distance from each other, that it may burn gradually out from one End to the other, without catching Fire in more Parts than one. The Length of it must be proportioned to the Time you design it should burn, or to the Period you prefix for

H h h h

the

the Combustion of your *Ball*: There will be no Difficulty in doing this, if you know exactly what Length of your *Match* will be consumed every Quarter of an Hour: Thus if you propose that your *Ball* should perform its Effect in two Hours after it is hid, and you are assured that about half a Foot of *Match* consumes every Quarter of an Hour, you may readily conclude that in this Case you must allow 4 Foot of *Match*.

The other *Ball*, distinguished by B, is commonly made of Wood (though it may be made of Iron or Brass like a common *Grenado*, but then it must be filled with *Corn Powder* only, for Reasons above given.) It must have a Serpentine or Spiral Fluting or Channel wrought in its Convexity from the Bottom to the Top, in which Fluting or Hollow you must glue your *Match* from one End to the other of it, as may be seen in C. This Sort is much better contrived than the First, because the *Match* is as it were a constituent Part of the *Ball*, and does not take up so much room as the former.

In short, the Third *Ball* (D) of this Kind has nothing extraordinary in its Construction. It has only a Stick in its *Vent*, round which is twisted a *Snake of Match*, which must be of due Length (as I observed before) and firmly glued to the said Stick, that it may not unfold itself in burning.

These *Balls* should be filled with very strong *Compositions*, and such as are very pregnant of Fire; as for Example, such as was anciently the *Grecian Fire*, the *Composition* of which I have given you from *Scaliger* in our *Chapter of Fire-Rain*. Now this Mixture will be sufficiently violent, as well because of the *Igneous Ingredients* it is compounded of, as on the score of the particular Manner of its Preparation; for Experience evinces that a Duing-heat has a wonderful Power of transforming, and as it were vivifying whatever is buried under it; in which it imitates Natural Heat: That *Genial Mother* who works such Wonders, and has reserved to herself a Power of putrifying, which is altogether surprising! For we find that the Animals generated from Putrifaction, are as various as the several Things that are putrified. Whoever reflects upon this, and considers it attentively, may turn it to very good Advantage. Upon this Account, I think that such a *Composition* would be preferable to all those which only have their *Ingredients* mixed up together without any farther Preparation; though I must here make an Exception with regard to *Gun-powder*, which being beaten and pounded for a considerable time, becomes extremely vehement (as I have elsewhere observed) and is transformed into a perfectly Light and Volatile Substance.

Brechtelius in *Book II.* and *Chap. II.* of his *Artillery*, gives us the following *Composition* for the Use of these *Balls*. Take 3 lb of *Powder*, and one lb of *Sulphur*; reduce them to a very fine impalpable Meal, and incorporate them well together: Then add to them a little *Colophone*, and some Drops of *Turpentine*; and knead them all up in a Dough or Paste

Paste with *Linsfeed Oil* and *Brandy*: Thus the whole being perfectly incorporated, fill your *Ball* with it. However I think it will be better to use something of the Nature of the *Grecian Compositions*; because our clandestine Fire is nearly related in its Effects and Operations to the forefaid *Fire*; as we are informed by several creditable Authors: As to the *Ingredients*, I do not apprehend that they can be wanting to you, either on the Score of their Scarcity or Price. Remember that instead of *Match*, you may use some of that *Pyrotechnic Slow Tow*, which *Brechtelius* mentions in *Part II. Chap. II.* of his *Artillery*, and which we have given you in our *Second Book*.

C H A P. XVII.

Of RED-HOT BALLS.

THE Practice of shooting *Red-hot Iron*, is far from being of modern Date; for long before the Invention of our *Artillery*, it was the Custom of the *Ancients* to defend themselves with *Red-hot Iron*, as is testified by *Diodorus Siculus*, who saith: *That the Tyrians threw great Bodies of Red-hot Iron into the Works of Alexander the Great.* An uncertain Author also speaks to this Effect in *Suidas*: *They threw from Eminencies whatever was Liquid or Fusible, scalding hot upon the Enemy. And amongst other Things Red-hot Pieces of Iron, which they kept ready for those who attempted to scale their Walls.* † *Vitruvius* also speaking of the People of the Town of *Marseilles*, saith, *That they threw Bars of Red-hot Iron from Balistæ to burn the Besiegers Works.* If you would be farther informed upon this Head, you may consult those Authors, whose Testimony we have all along recurred to. But to dwell much upon the great Request *Red-hot Balls* have been in since the Invention of *Gun-powder*, or to recount the Havoc they have made, or to relate their frightful Executions in the several Occurrences of *War*, would be giving of myself a needless Trouble; since none can be Strangers to this matter, but those who have never borne Arms, or never dealt in *History*, which does furnish us with many Examples of this kind: Amongst which ‡ *Emanuel de Meteren* in his *History of the Low-Countries*, relates the following Instance to have happened at *Rhinburgh* when it was besieged by the Admiral of *Arragon* in the Year 1598, (viz.) *A Red-hot Ball* (it must have been *Red-hot* though he does not expressly say so) *being shot from the Besiegers Batteries against a Tower where the Besieged kept their Gun-powder, it went through the Wall of it which was but a Brick thick, and fell into a Barrel of Powder; which imme-*

† Vitruv. Lib. X. Cap. XXII.

‡ Em. de Met: Lib. XX.

diately taking Fire accended all the rest, which were to the Number of 150; upon which ensued such a prodigious Clap, and such a general Conflagration, that it not only blew up the Tower it was kept in, but set Fire to the most lofty Houses in the Town, and shattered those in the Neighbourhood of it in pieces; threw down a great Part of the Town-Wall, and what is still worse, the most considerable Part of the Soldiers and Inhabitants, together with the Governor, were buried under Ruins; in short, there was hardly any Body in the Town escaped without being so miserably disabled, as to be unfit ever to bear Arms again, or incapacitated to work at their Trades. Paulus Piascius Bishop of Premislaw, who wrote our *Annals*, has the following Narration. From thence marching his Troops (he speaks of the Admiral of Arragon) towards the Rhine, he besieged Rhinburgh a Place belonging to the Archbishop of Cologne, which had been formerly in Possession of the Spaniards; but during the time that the Arch-Duke Albert was in France, it was reduced by the Hollanders, who afterwards kept a strong Garrison in it. The Besieged at first made a brave Resistance; but a Cannon Ball being accidentally shot into a Powder-Magazine there ensued a general Conflagration and Ruin; it made a great Breach in the Town Wall, upon which the Besieged were obliged to Capitulate, who being allowed good Quarter, and permitted to march out with their Baggage, they evacuated the Town. But † Diegus Ufanus gives us a Relation almost as Tragical as this, to which he adds an odd Accident that befel a Dutch Ship which was going into Ostend with a Lading of Gun-powder; (namely) that she was blown up by means of a Cannon Ball: This Author is of Opinion, that these two Casualties were not owing to what we apprehend, but that the Ball accidentally struck against some Stone, Piece of Iron, or some other hard Substance, and sent forth abundance of Sparks, which were the Cause of these melancholy Accensions. But I am rather inclined to believe (in which Emanuel de Meteren seems to agree with me) that it was some Red-hot Ball which was shot with Design to perform such an Effect; for it is not to be imagined that because a Ball has pierced through a single Brick Wall, or a Ship's Plank, or struck upon the Head of some Nail, that it can strike such a Fire as to be able to penetrate through a Powder Barrel: No; it is more probable that some Deserter going over to the Enemy, had informed them where such and such Powder was lodged, or what the Ship was laden with, and that thereupon they took the proper Measures to blow up the Gun-powder which is most usually done by Red-hot Balls; for there is no kind of Ball (though our Art has invented many) which is so convenient for conveying Fire and Destruction as these; for they at once perform the Office of a Cannon-Ball and of a Fire-Ball; add to which, that it cannot be perceived during the time of their Projection, whether they be Red-hot or not.

† Di. Ufa. Treat. II. of his *Artillery*, Dialogue XII.

Here we might repeat what we formerly quoted from *Lipſius*, concerning the *Fire-Balls* which are commonly ſhot from *Cannon*; for I am of his Mind when he thinks that *Red-hot Balls* might be as effectually ſerviceable as *Fire-Balls*; and I conceive that what ſo grave and famous a Perſon ſaith ought to have its due Weight with us. Now to ſhew that this Opinion of his is not ill-grounded, our Hiſtorians who have recorded the mighty Exploits of our glorious Kings have made no Diſtinction between them; but have promiſcuouſly uſed the Words *Kule Ognifte*, to ſignify all thoſe *Balls* which are contrived to burn Ediſices, Intrenchments, Palifades, and other Wooden Defences of *War*, which answer to the *Latin* Expreſſion *Globus Igneus, vel Ignitus*, or a *Fire-Ball*; this (though improperly enough) is applied to *Red-hot Balls*: Moreover, the Signification of the *Latin* Words *Igneus, Ignitus*, and *Candens*, is Synonymous, and they are indifferently uſed to expreſs one and the ſame Thing.

I do not think it worth while to waſte more Time in perſuading you that *Red-hot Balls* are very uſeful and ſerviceable upon Warlike Occaſions, that being a Point which has been indifputably demonſtrated by many Authors before me; I therefore have nothing more to do than to tell you what is obſerved in ſhooting them.

Fiſt you muſt charge your *Gun* with the uſual Requiſite of *Powder*, and ram it down with a Wooden Tompion that exactly fits the Chafe of the Piece, the Thickneſs of which ſhall be equal to, or not much leſs than the Diameter of the *Ball*; and for the more Security, you ſhall add to it a Wadd of Hay, Straw, or Tow, or (what will be much better) of the Sinews of Animals ſpread out like Tow, and previouſly moiſtened. This done, you muſt carefully ſpunge the Inſide of the Piece for fear any Grains of *Powder* ſhould be accidentally ſcattered in it; and then, point or level your *Gun* at the Place you deſign your *Ball* for, according to Art; and let it remain in that Poſition till you put in the *Ball*, which ſhall be perfectly round, and run freely down the *Chafe*: You may take hold of it with Iron Tongs or Pincers, from the Forge, which muſt not be far from the Battery: As ſoon as you think that it is ſlipped down upon the Wad, fire off your Piece.

There are thoſe who drive Boxes made of Iron or Copper Plates into the *Gun*; and others who uſe Clay, and then ram the *Ball* as faſt as they can towards the *Powder*, with a *Rammer* armed at the End with a Copper Plate; but the Fiſt Way I have here mentioned is by much the ſafeſt, and leaſt ſubject to Danger.

C H A P. XVIII.

Of Pyrotechnic Hail, by which are meant Cafe Shot, or Cartouch Shot, Partridge Shot and Grape Shot.

WHAT *Pyrobolists* mean by *Pyrotechnic Hail*, is a Parcel of little Hard Bodies, which being projected perform an Effect after the manner of Natural Hail; but it is somewhat more Hard and Perilous; our *Artificial Hail* being mostly of coarse Gravel, River Pebbles, or any Stones of the bigness of a Pigeon's Egg, and sometimes of Leaden Balls or Slugs, or little Bits of Iron, and all such like Things.

This *Hail* is usually shot at the Enemy, with our *Mortars* or *Hobbits*, and other *Field Pieces*.

This *Shot* is variously ordered; for sometimes it is shut up in *Wooden Cafes* or *Cartouches*, as you see in *Fig. 160*, under the Letters A and B; and sometimes in Copper or Iron Boxes, as you see in D and E; finally, you must run Pitch into the Interstices of it, to keep the *Bullets*, *Stones*, or whatever else it is composed of, together.

The Length of the *Cafe* or *Cartouch* shall be $1\frac{1}{2}$ or 2 Diameters at most of the Chafe of the *Gun* or *Piece* it is to be projected from; and the Bottom of it shall be half a Diameter in Thickness, the Lid or Cover $\frac{1}{2}$, and the Sides $\frac{1}{4}$ only. I here speak of *Wooden Cafes*; for those which are made of Metal, must be quite different from the abovementioned in every respect but their Length.

There are those who do not take so much Trouble with this kind of *Shot*: They first load the *Piece* with *Powder* as usual, and ram it down with a *Wooden Tompion*; upon which they pour in *Partridge* (as this *Shot* is sometimes called) to the Height of an *Iron Bullet* of the same *Calibre* with the *Piece*, and add a common Wadd upon it.

Others put it into strong Canvas Bags. I have represented one Sort to you in the *Figures G* and *H*, which is very pretty, and in the Form of a Bunch of Grapes: The ordering of this is very easy. In Letter *F* you have a *Wooden Tompion* with a perpendicular Rod stuck into the Center of it. The Bottom of the Bag must be sewed up pretty strongly, and then filled with *Leaden Bullets* of 2, 3, or 4 *Ounces*. You must then fasten your Bag at Top, and pass Marline over all the Interstices of the *Balls*; in such Form that the Circumvolutions of it crossing one another, it may look like a Net. This done; dip the whole into Pitch.

Again;

Again; there is a Way (which is none of the most despicable) of making it into *Balls*, as may be observed in the Letter C, which is done thus.

Take of *Pitch* 4 Parts, of *Colophone* one Part, of *Wax* one Part, of *Sulphur* two Parts, and a little *Turpentine*: Melt these over a slow Fire, and being melted, throw into them 8 Parts of *Quick-Lime*; 4 Parts of *Powder of Tiles*; and one Part of the Filings of *Iron* or *Hammer-scales*. Incorporate all these *Ingredients* well together: Which done, add to them as many *Pebbles* or *Musquet-Balls* as are needful. Whilst this *Composition* is cooling, make it up in *Balls*, that may exactly fit the *Gun* or *Mortar* you intend to use.

There are those who make this *Shot* into *Balls* with *Plaster*, or *Powder of Alabaster*: But I shall refer you to *Stone-cutters* and *Statuaries* to inform you, how you are to manage these *Materials*. Others again, make it into *Balls* with *Dirt* or *Clay*, which they set to dry in the *Sun* and *Wind*.

This *Shot* or *Hail* (as we have called it) is particularly useful in *Open Pitched Battles*; or when the *Besiegers* are resolved upon a *Storm*; or endeavour to possess themselves of an opened *Gate*; or mount a *Breach*; it is then that the *Cannon* and *Mortars* play this *Shot* in abundance, to introduce *Death* and *Confusion* among the *Affailants*.

The *Requisite* of *Powder* for projecting these, must be the same as is ordinarily allowed for a common *Bullet*.

C H A P. XIX.

Of several Sorts of Chain and Bar-Shot, &c.

I Here present you with *Figures* of several Sorts of *Chain* and *Bar-Shot*, and some other dangerous *Weapons* of a like Nature; which are most commonly used in *Sea-Fights* to disable the *Enemy's Ships*, by cutting their *Rigging*, *Sails*, *Yards*, *Masts*, *Rudders*; and for destroying several other *Parts* of a *Ship*, the Names of which are known to *Seamen* only: And at the same time they do *Execution* upon the *Ship*, they may destroy the *Ship's Company*.

The several *Kinds* of this *Shot* may be easily apprehended by the *Figures* 161, 162, 163, 164, 165, 166, 167, 168 and 169. *Fig.* 170 Fig. 161, 162, 163, 164, 165, 166, 167, 168, 169, 170. represents a *Box* or *Cafe* into which the five Sorts of *Chain-Shot* (which you see) are put when they are projected. That *Trundle-Shot*, which you see in *Figure* 161, has its particular *Box*, which you see represented beneath it, and distinguished by *A*; the three others need no Addition to them when they are fired away.

All these will do terrible Execution in Skirmishes, Assaults, and powerful Incurfions of the Enemy, &c. In fhort, the two laft, in *Figures* 168 and 169, will be useful in deftroying Palifado's, Fraifes, Crow-Feet, *Chevaux de Frifes*, Herfes, Portcullices, Fafcines, and all kinds of Wooden Defences and Coverts. In fine, they will ferve to ruin, and overfet *Baskets*, *Gabions*, *Batteries*, *Chandeleers*, &c.

I apprehend that it will be unnecessary for me to inftitute you in the particular Ufes of these Things, fince a little Practice and Study will inform you more to the Purpose, than all the Rules and Directions I could lay down.





OF THE
GREAT ART
OF
ARTILLERY.

PART *the* FIRST.

BOOK V.

Which treats of several Warlike Machines, fix'd and moveable, Bodies of Fire, and other Pyrotechnic Arms, as well for War as Recreation.

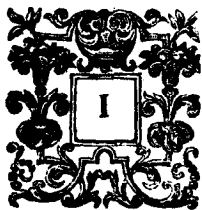

IN this *Book* you will have a Collection of the principal and most artificial Inventions in all *Pyrotechnics*, one Part of which shall be under the Denomination of *Machines* or *Engines*; the other, of *Bodies of Fire*; some of *Missiles* or *Projectiles*, and *Artificial Arms*, not to mention the particular Denominations of each of them. We might indeed range them all under the general Title of *Machines*; the Signification of that Word (according to the Definition of *Africanus*) being applicable to *all such Things wherein the constituent Matter is not so much considered, as the Artifice of the Invention, or the Skill of the Inventor*: And we may safely say of the Productions of our *Art* in general, that they can boast of the Fertile and Judicious Conceptions of their Inventors: From hence it is that the *Latins* called *Architects* and *Engineers*, *Igeniarii* or *Ingeniosi*, in which the *French* have imitated them, by calling all such Persons *Ingenieurs*; (and the *English* have not much deviated from them, in calling them *Engineers*;) but this is no Place for tracing up the Etymology of this Word to its Source.

Upon the whole, the Words *Machine* and *Machination* are of very extensive Import; for under them are couched all Frauds, under-hand Practices, Stratagems, Plots, Ambuscades &c. from whence it is that *Cicero* the Prince of Orators says, † *Isdem Machinis sperant me restitutum posse labefactari, quibus antea stantem perculerunt*: 'They expect to subvert me by the help of the same *Machines*, wherewith they threw me down before from my Prosperity;' here you are to understand the Word *Machine* to signify deceitful or malicious Efforts. *Brutus* also saith: ‡ *Omnis adhibeo Machinas ad tenendum Adolescentem*: 'I leave no *Machine* unworked to prevail upon that Young Man:' Meaning thereby, that he left no Means unpractised to restrain his turbulent unruly Spirit. Now I apprehend that I should have much more Reason to apply this Word to signify all our Pieces of Ordnance, whether Ancient or Modern, such as *Cannon*, *Culverins*, *Chambered Peices*, and other such like: Under this Denomination we might also range *Musquets*, *Arquebusses*, or (as they were formerly called) *Murthering Pieces*, and all other portable *Fire-arms*; as also *Mortars* and *Petards*, which bear a near affinity in Effect to the *Machines* of the Ancients, such as their *Rams*, * *Onagri*, *Balistræ*, *Catapultæ* and *Scorpiones*, with which they beat down Walls, destroyed the *Encinits* of Towns, and from whence they projected offensive Weapons. But *Lippus* (and several other Authors) has not honoured them with the Title of *Machines*, and only calls them by the general Word *Tormentum*, which is now used to signify our *Cannon* and Pieces of *Ordnance*; reserving *Machine* for *Battering Towers*, † *Plutei*, § *Musculi*, running or rowling *Towers*, ‡ *Sambucæ*, *Tollenones*, and all sorts of *Scaling Engines* or *Ascents*, and all those Things, under which were fixed the *Tormenta* beforementioned, and under which they covered their Soldiers when they attacked a Fortrefs or scaled a Wall. In truth, he was in the right to make such a Distinction between them, since their Functions and Offices were so different: Just as here we use this Word *Machine* to signify only, certain Artificial Inventions or complicated Heaps of Artificial Fireworks, such as *Palaces*, *Triumphal Arches*, and other Edifices adorned according to the Rules of *Civil Architecture*, *Castles*, *Towers*, *Columns*, *Pyramids*, *Obelisks*, *Colossuses*, *Medallions*, several sorts of *Human Statues*, and the Representations of several Animals, together with *Fountains*, *Terrestrial* and *Aquatick Fire-Wheels*, with several other Things of this kind, which we shall treat of in their proper Places; all which we have called *Machines*, not so much on the score of their Forms (which are vastly various) as on account of their Effects, with regard to which they not only walk hand in hand with the *Machines* abovementioned, but likewise exceed them very considerably. We might indeed have taken in all manner of Pieces of Ord-

† Tull. Cicero pro Dom. 17.
shooting of Stones.

‡ Brut. Epist. XVIII.

* These were Engines for

|| These were a kind of moveable Pent-houses or Galleries.

§ These were much the same with our Galleries.

‡ These were for scaling of Walls.

nance under the general Title of *Cannon*; but because they vary so much from each other in Form, Effect, and Property, as well as in handling; and since the particular Construction and Use of each of them require a select Treatise apart, in order to inculcate a proper Idea of them into the Reader; they shall each have a particular Chapter to themselves in the *Second Part* of our *Artillery*. Now to illustrate that the Word *Machine* would be no improper Term for our Use, I shall first recur to the Testimony of *Moses*, where he saith, † *Only the trees which thou knowest that they be not trees for meat, thou shalt destroy and cut them down, and thou shalt build Machines against the City that maketh War with Thee until it be subdued.* And in the second Book of *Chronicles*, where mention is made of King *Uzziah*: ‡ *And he made in Jerusalem Machines invented by cunning Men to be on the Towers and on the Bulwarks, to shoot Arrows and great Stones withal.* Again; that *Illustrious Prince of Architects* and great *Engineer Vitruvius*, still farther confirms me in what I have been saying, by placing *Balistræ* (from whence our modern *Cannon* are derived) in the Rank of *Machines*, giving us their Order and Distinction to this effect: * *A Machine is the Assemblage or Conjunction of several Members, and calculated for removing vast and ponderous Bodies; The Motion of which is artificially contrived by the Help of Wheels and other Circular Movements. The Scanforium or Scaling Machine is of one Sort, the Spiritale or Pneumatical Machine of another, and the Tractorium or Draught Machine of a Third Sort. The Scaling Sort is adapted for Persons to climb up, by means of Cross Pieces of Wood or Steps, without any danger, and to help in the overlooking of a Place. The Pneumatical Sort, by the Inflation of Wind or Air, expresses Organic Sounds, &c. And the Draught Sort is for carrying, removing or raising up great Weights or Burthens. The Scaling Machines do not so much glory in their artful Contrivance, as in the Boldness of the Attempt, and are composed of Chainings, Transoms, Bindings, Joints, Buttresses and Props. The Wind Machines are capable of very notable Effects. But the Machinæ Tractoriæ or Draught Machines, are the most Noble of all, as they are more Magnificent, and with a share of Prudence applicable to mighty Uses: The Action or Motion of some of these is Mechanical, and of others Organical. Between Machines and Organs there seems to be this Difference (namely) the First of them require the help of many Hands or additional Strength to assist them in the performance of their Effects: Such as the Balistræ and the several sorts of Presses. And the latter on the other hand operate by the slight artful Touch of a single Person, as may be observed in the Projections of the Scorpionæ and || Anisocyclæ; therefore are they both useful in different*

† Deuter. XX. In these two Scriptural Passages our *English* Version uses the Word *Engine*.

‡ Chr. Book II. Chap. XXVI ver. xv.

* Vitruv. Lib. X. Cap. I.

|| This was an Engine composed of a great Number of Wheels or Movements.

Respects and Occurrences, and without them we should be oftentimes embarrassed in the carrying on of Works.

From hence there may be those who will object against me, and say, that our *Cannons, Mortars, Petards, &c.* might be more properly called *Organs* than *Machines*, and that they particularly ought to be called so (according to the Definition above from *Vitruvius*) because the greatest Part of them may be managed and governed by one Person. But to this I reply; that the Word *Organ* cannot for that Reason obtain with regard to the Greater Pieces, such as some of the larger *Cannon* and *Mortars*, which cannot be loaded and played by one Gunner, or laid to pass by one *Pyroballist*; but require the Work of many Hands; add to this, that they not only require to be tended by a Number of Men; but it is also necessary to have Horses to move and transport them from Place to Place: But I must confess that Musquets, Pistols, and other Portable Arms might not improperly be called *Organs*, as well as the *Scorpiones*, Bows, and Cross-Bows of the Ancients: However, if this will not satisfy you, e'en call them *Machines*, as we have called our *Cannon*, and as the celebrated *Ericius Puteanus* has called them in his little Book of the *Treble-Barrelled Gun* invented by *Mic. Flor. Langrenus*, where he saith: *At length, though late, the Firelock, that Machine of Machines, was invented, and was first used by the Danes.* (And a little lower) *Now since this Machine is contrived to carry three Bullets, very conveniently and in very little Room, &c.* And a little lower he does not even scruple to call Pistols *Machines*. This answers very much to our Purpose; but let us resume our Subject. Comprehending then all the Warlike Instruments above recited under the general Denomination of *Machines*, we will under the Title of *Bodies of Fire* take in the several *Pyrotechnic Tubes* or *Cases* as well Recreative as Warlike, *Cylinders, Stocks, Barrels, Sacks, Baskets*, to which we will add *Crowns, Garlands, Fire-Hoops, Staves, Cups*, and all other Artificial Fire-Works of that Kind. Under the Title of *Missiles* (by which are meant *Projectiles*) we will range *Fire-Darts, Arrows and Javelins, Fire-Pots and Flasks*: Under this Head we might also dispose of our Recreative and Military Globes, all which we have amply treated of in the Preceding Books; but each of them being already distinguished by particular Appellations, they seem to be excluded from this List: And indeed they bear little or no Resemblance to these in Point of Form, though they may with as much Propriety as these be styled *Projectiles*, from their being either thrown or shot. In fine, under the Title of *Artificial Pyrotechnic Arms* we comprehend *Targets, Shields, Swords, Poles, Clubs, and Lances*.

And upon the whole, as these Things are partly *Recreative* and partly *Warlike*, we will divide this Book into two Parts; the First of which shall treat of the *Former*, and the Second shall instruct you in the *Latter*.

P A R T



PART I. *of this* BOOK.

Which TREATS of

RECREATIVE MACHINES,

*Masses or Bodies Fix'd and Projectile, and
Arms Artificial and Pyrotechnical.*

CHAP. I.

Of Artificial Shields and Bucklers.

SORT I.



TAKE two Fir or Lime-Tree Boards well dried and planed; Fig. 171. of the Thickness of a Finger or thereabouts; and get them made Round by a Joyner, if you cannot do it yourself. They may be 3 Foot in Diameter, but that is left to the Discretion of the Workman. Upon each of these Round Boards trace out a Spiral Line, beginning from the Center of each of them, and continue it within an Inch of the exterior Circumference of them: The Revolutions of these Spirals must be Parallel or \AE quidistant from each other, and their Distance may be 3 or 4 Inches or Fingers. Along these Lines, you must cut out a Groove of equal Breadth and Depth throughout, with an hollow Chissel (I shewed you some such in *Book III.*) or some such Tool, so that these Grooves may either bear the Form of a Concave Semi-Cylinder, or of a Parallelopiped. The hollow Channels or Grooves when they are narrowest shall be always 6 Lines, and when broadest one Inch. These Spiral Cavities must be wrought upon each Board with such Exactness and Nicety, that when you come to join them together the outward Extremities of each may exactly meet and correspond with one another, in such manner that from their Meeting or

Termination they may mutually involve together, and form a Spiral Hollow Cylinder; and therefore if you would have them answer curiously in this particular, you must so order it that the Spiral Lines you first draw upon the aforementioned Boards, may be exactly in the middle of the Channels or Grooves which you cut out, or sink into them. This done, you shall fill the abovesaid hollow Spiral Cylinder with *Quick Match* loosely twisted, or with a *slow Composition* sprinkled over with a *Gum Water*, that it may stick together and adhere the better; to the end that when you come to join your Boards, the *Composition* may not fall out of your Spiral Cavities, and by that means waste your Time and frustrate your Labour. This done, nail them together, and to secure them still the better, you may also glue them. After this, you shall trace out a Spiral Line upon the outward Surface of either of your Boards, (so as exactly to correspond with the interior Spiral) which must be bored with small Holes, into which you must thrust the Fuzes of such *Crackers* as I gave you in *Fig. 108* under the Letter B, which *Crackers* must be at the Distance of two good Inches from one another, for fear when any one of them in particular goes off and bursts, it should some how or other incommode those next to it: And therefore must their Fuzes be firmly glued in the Holes they run into, and themselves be well glued to the Board, and re-inforced with thin Iron Plates on the Outside, or with good Marline or Packthread to prevent them from flying abroad. To the Inner Side of this *Shield* (by which is meant that Side of it which is next to the Body) you shall fasten two Straps or Loops of Leather, or something of that Nature, that you may conveniently handle your *Buckler*. In short, you must paste or glue a single Paper over all these *Crackers*, which must be done so artfully as to swell out in a round Knob or Boss, or else project in a Spike or Point towards the Middle, and by means of the Boss or Spike bear the exact Resemblance of a real *Warlike Shield*: And in order to disguise the whole the more effectually, you shall paint it over of an Iron or Copper Colour. There now remains nothing farther to do in this Case, than to bore an Hole whereby to fire it, if so it be that your Inward Cavity does not come out to the Edge of the *Shield*. When you would have the Pleasure of seeing the Effects of this, set fire to the inclosed Matter without apprehending any Danger, and let the Person that holds it stand firm at the Explosion of each of the *Crackers*, and not offer to throw away his Arms till the whole Process of its Operation is completed. See *Fig. 171*.

S O R T II.

Fig. 172. What we have ordered for the preceding Sort as to the Proportions of the Boards, the Form, Size, Spiral Lines and Cavities, the filling of them with *Quick Match*, the Fastening and Conglutination of the two Boards,

Boards, the Straps or Handles, and the Manner of covering the whole, must be likewise observed in the Construction of this: There is only this one Article that constitutes a difference between them, (namely) That instead of *Paper Crackers* parallel to the Plane of the Surface of the *Shield*, you must stick in *Running Rockets* or *Iron Crackers* perpendicularly to the said Plane: The Holes for receiving them shall be bored close home to the included *Match* or *Composition*, and shall be of such Breadth as is required by the Size of your *Rockets*, &c. Observe here, that your Inner Cavity that holds your *Match*, may be made a little narrower than in the preceding *Shield*; because the Fire pursuing its Course in that Spiral Direction, and successively preying upon the included Matter, its breathing Holes or Vents are larger, and in greater Number, by its driving out these *Rockets* and *Iron Crackers* than before. Letter A points out the Place where you are to prime, and set fire to the whole. See Fig. 172.

S O R T III.

The *Figure* which you see in 173, represents the Form of an ancient *Escutcheon*. This also is constructed much after the same manner with the above *Shields*, it being composed of two light Boards: But there is this Difference subsisting between them, that the Interior Cavity of this is not formed in a Serpentine or Spiral Direction, but is only a Complex Line according to the Breadth of the *Escutcheon*; I mean, that you must draw Parallel and Vertical Lines (at the Distance of at most a Finger from the Edges of the Boards) which last must alternately be produced from the Extremity of one Parallel Line to another; so that by their mutual Terminations in each other, they may all together form as it were one continued Line, and consequently that the Cavities hollowed out in that Direction may be one continued Cavity composed of several Branches (something like the Meanders of a River) descending from the Top of the *Escutcheon* to the Bottom. The Parallel Lines or Cavities shall be 2 or 3 Fingers from each other, as we said above. The Holes which you bore for your *Running Rockets* or *Crackers* must be in such order as not to be directly under each other, but in such a Position as to be Triangular-wise, or in such Manner that four of them may include or form a *Rhombus*, composed of two similar and equilateral Triangles, by means of which the *Rockets*, &c. will be at a convenient Distance from each other. As for any thing farther relating to the *Escutcheon*, it is the same with what we have above directed. You may contrive to give it an artificial Belly or Swelling in the Middle according to the Bigness of it, that it may have the better Appearance, and that rising out towards the Middle it may have the Shape of a Pan-tile, or something of that kind.

S O R T IV.

I here present you with another *Efcutcheon* which is of an Oval or Fig. 174. Elliptic Form, as you may see in Fig. 174 : The Construction of this is something like that of the preceding ; but instead of fingle *Rockets* or *Crackers*, you must have little Wooden Boxes, or Paper Cafes, or *Cartouches* as A, filled with *Running Rockets*, which shall be alternately disposed as in the last Sort, (*viz.*) Triangularly or Rhombufidical. Your Cavities aforementioned must be in Proportion to the Length and Breadth of the *Efcutcheon*, and the Parallels may be joined as in the last Sort by Vertical or Transverfal Lines or Cavities, which shall turn to and exactly humour the Sweep or Form of the *Efcutcheon*, as in the foregoing Sort. Upon the whole, you may (if you please) make your Inner Cavity in a Spiral Direction, exactly answering to the Form of the *Efcutcheon*, and then dispose of your Boxes or Cafes just as you did with the *Rockets* and *Crackers* in the first and second Sort : However, you must take care that the Revolutions of your Spiral Cavities (and the same thing must be observed, if your Cavity is wrought in a Rectilinear Direction) are at a much greater Distance from each other than in the former *Figure*, and that, in Proportion to the Size of your Cafes, which upon the score of their Largeness ought to be at a greater Distance from each other than the fingle *Rockets* and *Crackers* that do not produce so great a Fire. If the abovesaid Cafes are made of Wood, they shall have their Bottoms bored with a small Hole, into which you must thrust one End of a little Fuze (made of Copper or Iron) filled with *Meal Powder*, which must be driven very hard in it ; the other End of each of these Fuzes shall go into the Board which forms one Side of your *Efcutcheon*, and must bear upon the Combustible Matter contained within it through small Holes made to receive them ; and by them the Fire will be conveyed to your Cafes of *Rockets*, and cause them to depart. If your Cafes are made of Paper, you may leave them open at Bottom, and let them into the Outward Surface of your *Efcutcheon* to the Depth of two or three Lines, and secure them fast with Glue, having first bored little Holes through the Board aforesaid, (which must be filled with *Meal Powder*) which must be exactly under the Middle of the Cafes. This done, you shall head up all your Cafes with Cornets or Paper Cones, if so it be that the outward Surface of your *Efcutcheon* is to be flat and bare, but if it is to be somewhat raised or swelled in the Middle (which may be easily done by a Covering of Paper or Cloth) their Heads shall be flat. Any thing farther relating to this, may be gathered from what has been said of the preceeding Sorts of these *Shields*.

S O R T V.

The last Sort of *Buckler*, which you see in *Fig. 175*, cannot be per-
 formed till you have a previous Knowledge of the Construction of *Fire-
 Wheels*: I shall therefore reserve what I have to say of it till I have
 treated of *Wheels*: I shall only here inform you, that this *Ejfcutcheon*
 may be of what Form or Figure you please, and that it must be made
 but of one single solid Board, and that the Surface of it may be flat, or
 swelled out in a Bofs in the Middle of it; and finally, that the *Fire-
 Wheel* must be fixed exactly in the Middle of the *Ejfcutcheon* or *Buckler*,
 upon a small Axle or a round Pin firmly driven into the Wood, that it
 may turn round the more freely. Every thing farther concerning this
Machine will be taught by the Sequel.

C H A P. II.

Of FIRE-CUTLASSES.

MAKE a *Cutlass* of two Pieces of smooth dry Wood, after the Fa-
 shion of a *Polish Sabre* or *Turkish Scymitar*, with a crooked Back
 and only one Edge, as may be seen in *Fig. 176*: Put the Edges of your
 two Boards together, and keep the Back open to the Breadth of two or
 three Fingers, so that between them there may be a Hollow, whose
 Profil or transversal Section answers to an *Isoceles Triangle*. Divide
 the whole Length of this Cavity by little Triangular Partitions of
 Wood, exactly fitting the Form of the said Cavity, and glue them well
 to the Innerfides of your *Cutlass*, and to fasten them still the better drive
 little Wooden Pegs into them from the Outside, or else little Brads:
 You shall then add a Gripe or Handle to it, that it may be conveniently
 handled and managed. But before you fasten in your little Partitions, it
 will be proper for you to make a little Groove or Channel within-side,
 right over the Conjunction of the two Edges of your Boards, into which
 you must put *Slow Composition* to the Height of half a Finger, or else
 you may lay *Quick Match* in it, and cover it with a thin Sheet of Lead,
 or with a thin Slip of Board, over which you must glue or paste a Piece
 of Paper, to keep it down upon your Priming. You must not forget to
 bore little Holes through which your *Composition* or *Match* may corre-
 spond with each of your Partitions, and accordingly fire the *Running
 Rockets* (or *Squibs*) *Stars*, *Sparks*, *Light-Balls*, or other such like Things
 wherewith those Partitions are usually filled up. In short, after having
 pasted a strong Paper over the Back of your *Cutlass*, you shall coat it all

M m m m

round

round with a Cloth, and paint the Blade of it in Imitation of Iron. If you would have any additional Pleasure from this *Machine*, you may on each Side of the Blade stick *Crackers* in *Saltier*; that is, in Form of St. *Andrew's* Cross, as may be observed in the *Figure*. The Touch-hole where you are to fire your *Composition* or *Match*, must be near the Point of your *Cutlafs*.

C H A P. III.

Of an Artificial † Hanger or Dagger.

Fig. 177. **T**HE Form of the *Hanger* which you have in *Fig. 177*, is not very different from that of the *Cutlafs* I just now described: This like the former is made of light dry Boards. The Edge of it is hollowed in the Form of a Concave Semi-Cylinder; in which you are to fix *Rockets* of 8 or 10 *Ounces*, more or less in Proportion to your *Hanger*, and in Proportion to the hollow Edge of it: You shall fill them with one of the *Slow Compositions* I have already given; but for want of them, the following *Composition* will do very well. Take of *Powder* 5 Parts; of *Saltpeter* 3 Parts; of *Coal* 2 Parts, and of *Sulphur* one Part; beat, mix, and incorporate them well together, and fill up your *Rockets* with it to the Brim, without capping them or adding any Report to them as is commonly done for *Rockets*; in short, without heading up or boring them at all, lay them open one upon another in the hollow Edge of your *Hanger*, and gluing them well on, cover them over with Paper. Furthermore, you may on each Side and on the Back of the Blade stick *Paper Crackers*, in such a manner as not to be shaken or torn off: To conclude, each of your *Crackers* shall correspond with the *Rockets* by little Fuzes filled with *Meal Powder*, through which the Fire may be conveyed to them from the *Rockets*.

C H A P. IV.

Of ARTIFICIAL SWORDS.

IT is wasting of Time to bestow more of it upon the Performance of any Thing than the Nature of it requires; a due Regard to which Maxim shall be had in this *Chapter*; for in truth, the *Figure* of the

† The French calls this *Demy-Espadon*.

Fire-Sword which you have in Number 178, needs not the least Expla-^{Fig. 178.} nation; for it differs in nothing but in Form from the *Artificial Hanger* above described: Therefore to avoid an impertinent Repetition of what has already been said, and the Trouble of inventing new Terms; I shall tell you in few and plain Words, that the Construction of the *Fire-Sword* does not vary a Nail's-breath from the Construction of the *Hanger* above.

CH A P. V.

Of FIRE-POLES or RODS.

YOUR *Fire-Poles* shall be of the Length of 10 or 12 Foot, and of^{Fig. 179.} the Thickness of 2 Inches at most. You must hollow one of the Ends of it with 3 or 4 Flutes to the Length of 2 or 3 Foot. Into one of these Flutes you must fix *Rockets* or *Squibs* prepared after the manner we ordered above; but in the others, you must fix *Paper Crackers* only; after having bored Holes through the Body of the Pole through which the *Rockets* may have Communication with the *Crackers*. Wrap them then neatly in Paper, the more effectually to deceive the Spectators. See *Fig. 179.*

CH A P. VI.

Of FIRE-WHEELS.

S O R T I.

THE most common and simple Sort of *Fire-Wheels* is that which you see represented upon our *Shield* or *Escutcheon* in *Fig. 175.* It^{Fig. 175.} is made of light Fir or Lime-Tree Boards well jointed together, and wrought in an Octangular Form. In the Center of it is a little Nave into which the Spokes of the Wheel are fixed, which support the Fells. The Eight Sides of this are fluted or hollowed just as we have ordered for the *Hangers* and *Poles*; into which Flutes or Grooves you glue large *Rockets* (namely) one, two, or more, according to the Dimensions of your *Wheel*. But it is in this Case necessary that your *Rockets* should be bored just like *Sky-Rockets*, and filled with the usual *Rocket Composition*; they shall likewise be choaked at Top, saving only a moderate Hole in the Head of each, by which the Fire when it has consumed
 one

one of them may pass to the next to it, and so on till they are all burned out successively one after another; but the Head of the last must be carefully stopped or closed up, and you must some how or other contrive that it be not in danger of being accended nor incommoded by the redundant Fire issuing from the first. To conclude, you may to this last *Rocket* add a Report of *Corn Powder*.

S O R T II.

Fig. 180. This *Wheel* is a little more Artificially contrived than the foregoing. As to the Form of it, it is perfectly round, and has a Flute or Groove all round the Convexity of it, into which are fixed such *Rockets* as we ordered above: On each side of the Fells (as they are commonly called) you must firmly fix *Paper Crackers*, which shall correspond with the *Rockets* by little Fuzes filled with *Meal Powder*. Fig. 180 will give you a compleat Idea of every thing else relating to it.

S O R T S III and IV.

Fig. 181. The Construction of the *Wheel* I am now going to give you is much the same with that of the First Sort, and in point of Form is exactly like it. But this exceeds the foregoing two, inasmuch as it has two Rows or Revolutions of *Rockets*, in consequence of which it has two contrary Rotations (namely) to the Right and the Left, or Forwards and Backwards. But you may imagine that these Rotations are not performed at the same time; but whirling round in one particular Direction till the lower Range of *Rockets* is spent, it turns back again by a Retrograde Rotation when the upper *Rockets* are fired, by means of a private Fuze. Cast your Eye upon Fig. 181, where you will see how all this must be ordered.

Observe here that all the *Rockets* (or *Wheels*) we have here mention'd must be either in a Horizontal or a Vertical Position; that is, whilst they are burning, they must turn upon an Iron Axle (such as you see in

Fig. 182. Fig. 182) either parallel to the Plane of the Horizon, or perpendicular

Fig. 204 to it. Under Fig. 204, I have represented an *Horizontal Wheel* distinguished by the Letter E, and close by it a *Vertical* one in the Letter G. Remember here that this *Horizontal Wheel* holds the Fourth Place of *Fire-Wheels*; because it is in some sort different from the rest; its superior Plane being all stuck full of *Running Rockets* (or they may be *Sky Rockets* if your *Wheel* is big enough;) add to which, that the Construction of it approaches pretty near to that of the *Shield* or *Buckler* of the Second Sort, with regard to the *Rockets* that are stuck into it: As to any thing farther concerning this *Wheel*, you may gather it from what has been said of the preceding Sorts.

Befides

Fig. N.º 152.

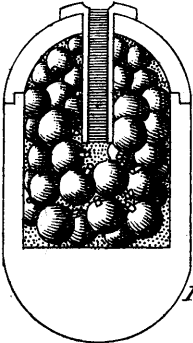

Fig. N.º 153.

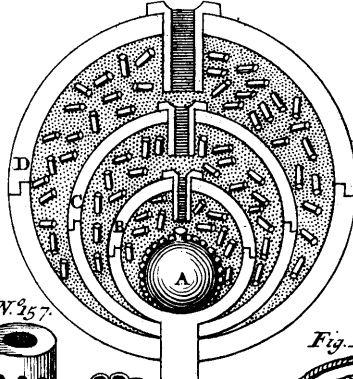

Fig. N.º 154.

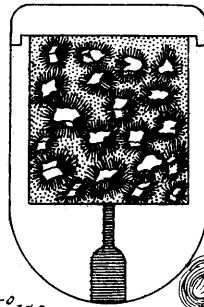

Fig. N.º 155.

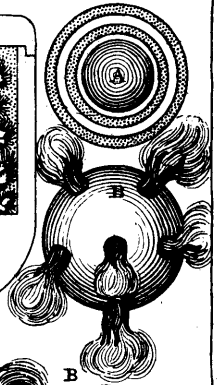

Fig. N.º 157.



Fig. N.º 159.

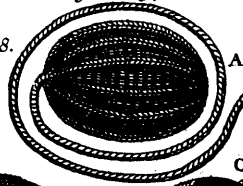

Fig. N.º 156.

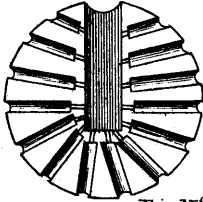

Fig. N.º 158.

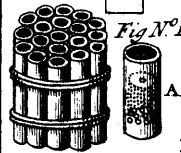

Fig. N.º 160.

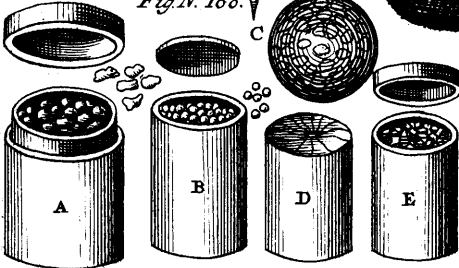

Fig. N.º 161.

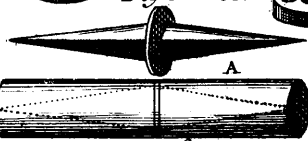

Fig. N.º 162.

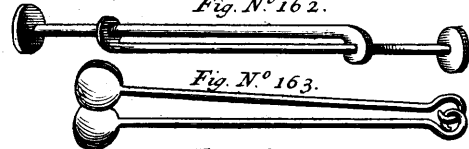

Fig. N.º 166.



Fig. N.º 163.

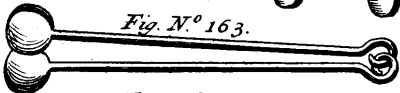

Fig. N.º 167.

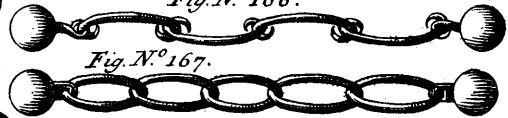

Fig. N.º 164.

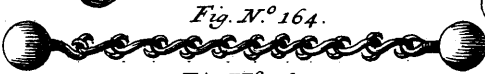

Fig. N.º 165.



Fig. N.º 170.

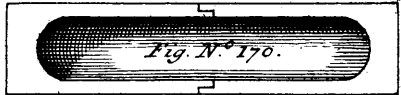

Fig. N.º 171.

Fig. N.º 172.



Fig. N.º 168.



Fig. N.º 173.

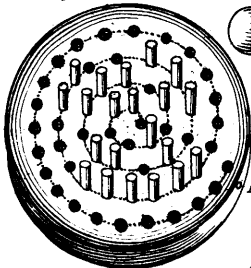

Fig. N.º 169.

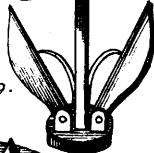

Fig. N.º 176.

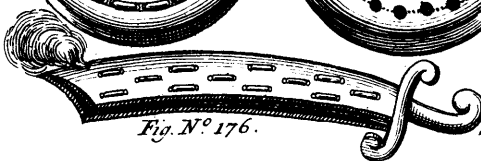

Fig. N.º 174.



Besides this; I here give you a round *Wheel*, of which is formed a Basin of a Fire Fountain. This you have in *Fig. 202*, distinguished *Fig. 202.* by the Letter B. The Plane of it is pointed out by E, but the true Orthography of it, and the manner how it is to be contrived so as to turn round upon a Tube or Case of *Composition* may be seen in F. But let us go on, for we shall have occasion to speak more particularly of this in the Sequel.

S O R T V.

In order to construct this Fifth Sort of *Wheel*, you must first have a *Fig. 183.* pretty large Wooden Bowl or Dish, with a broad flat Brim, such as you see in *Fig. 183*, under the Letter B. Then you must have a light, dry, square Board, of 2 or 3 Foot in Breadth each way. Saw off the Corners of this Board and convert it into an Octangular Table, and cut out a round Groove (or as the Original has it *Semi-cylindric*) all round the Thickness of it. This done; cut out a large round Hole in the middle of this Octangular Board, in which you must fix a Water-Globe, or something of that kind, or such as those we gave you in the Third Sort of *Running* or *Leaping Globes*; but be the *Ball* what it will, you must so order it that one of its Hemispheres may be hid and received in your Wooden Bowl, and the other rise up above your Octangular Board: Nail down this Board upon the broad Brim of your Bowl or Dish, and fix your Globe in the middle of it, as we said above, and tie it down fast with Wyre, or secure it by any other Contrivance so as to prevent its escaping out of the Bowl. This done; glue such *Rockets* as we said above in the Groove that runs round the Thickness of your Board, laying them close after one another, so that successively taking Fire from one another, they may keep (as long as they last) whirling the *Wheel* with one uniform Rotation. If you will you may add on each side of the *Wheel* three or four such Boxes or Cases as we mentioned above, which must be erected perpendicularly to the Plane of your Octangular Board: To conclude, you may upon the same Board or Plane range a Number of *Crackers* lengthways following one another; of these you may not only have one Tire or Range, but two or three Tires one within another, just as you fancy, and as the Extent of your *Wheel* (as we have called it) will permit.

Your private Trains or Fuzes shall observe the following Order; first conduct one to the *Rocket* which is to take Fire the first from the Globe fixed in the middle, whose Side must be pierced close home to the *Composition* it contains; let this Train be of *Meal Powder* and closely covered up. You must then have Trains or Fuzes of Communication from the *Rockets* to each Box or Case, and from them to each *Cracker*, and from the outward Ranges or Tires of *Crackers* to the Inner, if so it be that you have more than one. All these Trains must be of *Meal Powder*.

The Boxes or Cafes must be ordered and fixed, as we directed in our Fourth Sort of *Shields*. Finally, the whole as compounded of all its Parts shall be universally coated with Pitch, so that your *Wheel* being committed to the Water, that Element may not have the least Admittance into your *Trains*, *Rockets*, *Cases* and *Craekers*, nor into your Bowl or Dish; for except it be very substantially coated over, your Labour will vanish in Smoke, or (to speak more proper in the present case) turn into Water, and balk you of the Diversion you expected. In doing this then, the *Pyrobolist* will have an Opportunity of displaying his Industry and Skill.

Observe here this Firework must be enkindled in the Middle of it, and as soon as your *Composition* is thoroughly fired you must ease it gently down into the Water. Cast your Eye upon the *Fig.* where you will see a Curious Representation of every thing we have here described, distinguished by the Letter A.

C H A P VII.

Of Artificial Clubs or Maces.

S O R T S I and II.

I Shall not here take up your Time with a particular detail of the several Sorts of *Clubs* which *Pyrobolists* have been pleased to invent and describe; for (as I have already said) I do not propose to dwell upon any thing that is trivial, nor to sweep out our *Pyrotechnic Granary* to the minutest Straw, but only by an assiduous Labour and Industry to pick out the choicest Grains of our *Pyrotechnic Stores* for you: And therefore I shall only present you with the three following Sorts. The two first of which *Fig.* (184 and 185) are perfectly like the *Water Globes* of the Seventh and Ninth Sort, and therefore I shall refer you to them for the Construction of these. You need only add handsome turned Handles to them, such as you see represented in the Figures themselves, or any other that our *Pyrobolist* shall like better. To this I shall subjoin a *Composition* that I take to be more proper and convenient for these than what is usually made for *Water Globes*. Take of *Pitch* 1 lb; of *Sulphur* 3iij; and of *Coal* 3ij; beat, mix and incorporate them well together, and sprinkle them over with any fat, oily Substance or with Brandy, and charge your *Balls* with this Mixture: Or if you please to make use of the *Composition* we ordered above for the *Cutlafs* it will do very well and is very fit for this purpose.

S O R T

S O R T III.

Get a *Club* turned with its Handle and a Spheroidical Head, and let it have a Spheroidical Cavity withinside; but this Cavity must be so contrived that the Solid Substance of the Wood or Shell be throughout of the Thickness of five Inches at least: Or else it may be bored with a round Hole from the Top to the Middle of it, of the Breadth of 3 or 4 Inches. Farthermore, you must bore the Sides of it all round with Holes of the Diameter of 3 or 4 Inches, and to a Depth answering to the Length of a *Running Rocket*, all which Borings must tend to the Cavity in the Middle. Fig. 186.

You must then bore fine Holes branching from the Bottoms of these great Cavities, to that in the Middle, in which they must all terminate; and these shall be filled with *Meal Powder*. This done, make Paper Cases upon a Rowler, which must be a little less in Diameter than the Cavities abovementioned; these Cases shall be neatly pasted together, so as to slip easily into the Cavities they are to be fixed in; and if you will, you may make Paper Bottoms to them, provided that those Bottoms are pierced in the Middle to give the Fire Conveyance to the *Rockets* which are confined within them: Having fixed them in the Holes of the Head of your Club, you must cover each of them up with a Paper Cone, after having capped all your Cases with a round piece of Paper, to keep them from falling out of their Holes: You may fill the middlemost Cavity of your Club with the *Composition* we just now gave for the two foregoing Sorts; or you may use the following, which is much of the same Nature. Take of *Saltpeter* one lb; of *Sulphur* lb fs; of *Powder* \bar{z} iiij; of *Coal* \bar{z} ij. Finally, dip the whole Body of your *Club*, armed as it is with its pointed or conic Heads, into a good Quantity of melted Pitch, or coat it over with Glue; in a Word, paint it over of what Colour you please. See *Fig. 186*.

C H A P. VIII.

Of the FIRE-STAFF or STICK.

THE *Fire-Staff* may sometimes supply the want of an *Artificial Wheel*, inasmuch as it is contrived to turn and whirl round upon an Iron Nail or Axle, which is an Action common to *Fire-Wheels*: As to the Construction of it, it is neither very costly nor troublesome: You are to fill two *Sky-Rockets* of what Size you will with a futable *Composition* up to the Brim; and bore them to $\frac{1}{2}$ of their Height with a proper Borer Fig. 187.

Borer or Taper-bit. Then get a solid Wooden Ball turned with two Arms or little Axles Diametrically opposite to each other, and exactly fitted to the Orifices of the *Rockets* into which they are to be stuck. Bore then an Hole through the Body of your Ball, intersecting the Imaginary Line which passes through the Center of the Arms or Axles of your Ball at right Angles: To the Outside of these two *Rockets* you may fix *Crackers* all on the same Side; but their little Fuzes must be 2 or 3 Fingers from the Orifices or Heads of the said *Rockets*. On the Side opposite to these *Crackers* there must run a long Tube or Fuze, through which the Fire may be conveyed from the first *Rocket* that burns out to the Choak of the other; which shall be covered with a little Paper Cap, as we ordered formerly with regard to *Rockets* that run upon Lines. In the Profil (*Fig. 187.*) you see the Wooden Ball with its two Axles distinguished by the Letter A, as stuck into the Orifices of the *Rockets*; B and C are the two *Rockets* as filled with *Composition*, and bored as they ought to be. E and F are the Paper *Crackers*. D the Tube or Fuze; the rest may be learned from the *Figure* itself.

C H A P. IX.

Of the FIRE-CUP.

Fig. 188. **O**RDER a *Cup* or *Goblet* to be made of Wood or Metal, after the Fashion of any Drinking-Cup that you like best; as for me, I find none better adapted to this Purpose, than that which you see represented in *Fig. 188*: The Lower Part or Leg of it must be bored from the Foot up to its Concavity, into which Boring you shall thrust a Wooden or Metal Fuze filled with the following *Composition*, which will yield a very black obscure Fire. Take of *Pitch* \bar{z} iiij; of *Sulphur* \bar{z} ij; of *Coal* \bar{z} j; of *Crude Antimony* \bar{z} ij; and of common *Salt* \bar{z} j.

Fill the Capacity of your *Cup* with *Running Rockets* (or *Squibs*) after having salted the Bottom of it over with a Mixture of *Meal* and *Corn Powder* to make them fly out. Shut them in, and cover them with a round Board of the Thickness of 3 or 4 Lines, and that, to such a Nicety that the lower Surface of it may bear upon the Heads of the *Rockets*, and its Circumference exactly correspond with the Concavity of the *Cup*. Then pitch the remaining Cavity of your *Cup* up to the Brim, and cover the round Board upon the *Rockets* with a tarred Cloth, to keep it tight, and to prevent any of the *Pitch* from running in among the *Rockets*.

The ingenious *Pyrobolist* may apply this *Cup* to a thousand artful Uses; particularly in drinking to the Health of some Person of Distinction.

tion. He need only first fire the Fuze or Case that runs down to the Center of the Foot of this Goblet, and whilst that is burning, toss off at once what Liquor is in it, and immediately lifting it above his Head, keep it in that Situation till the *Rockets* are fired and flown out of the *Cup*: But I must here tell you, it is proper that you should have no more Wine in it than may be drank off at one or two Gulps; or else it may be necessary for the Drinker to have a Throat formed after the *German* Fashion (I ask Pardon) I mean the *Grecian*; to swallow it down at once, if there be a good Quantity of it; for in this Case you not only run the Hazard of burning your Nose, but also of spoiling your whole Face. Now besides the *Cup* I have here given you, you may consult *Fig. 200* and *201*, where you will find others.

C H A P. X.

Of Artificial Cases or Tubes.

OF all the *Pyrotechnical* Inventions that have been brought to light, there are none so important or necessary in the Construction of *Artificial Pyrotechnical Machines* (which we shall treat of in the subsequent *Chapter*) as these *Cases* or *Tubes*; for I believe it is impossible to think of any Contrivance, that would be more proper to fill up, support, and bear a whole *Machine*, or to throw out such a Diversity and Redundancy of Fires, in what Order and Succession the *Pyrobolist* thinks fit to prescribe, than these *Cases*, which are used in *Pyrotechnics*: And therefore I shall here present you with some of those Sorts which are in the greatest Request among *Fire-Engineers*; and that, in the most regular and conspicuous Order I am able. To begin,

S O R T I.

In *Fig. 189* you have the Construction of a *Case* composed of several *Fig. 189* Pieces or Boxes, whose Height is arbitrary, and may be as you please. Now all these Boxes have hollow Bottoms adapted to receive and cover the Boxes which are immediately under them. If these Pieces are made of Wood they must so exactly fit, and receive each other, that it may be difficult to distinguish the whole from one continued Piece: If on the other hand they are made of Paper (which I like best both on the score of their Strength and Lightness) you must, in Consideration that they are all of one Size, paste on a Foot or Bottom of about a Palm in Height so each of them, the Interior Circumference or Convexity of which Bottoms must exactly fit and correspond with the Convexity

vexity of the *Boxes* or *Cartouches* themselves: In short, they must be so contrived as to slip into and fit each other.

I know of nothing more convenient for the Construction of these *Boxes* than the Engine distinguished by the Letter A, and the two Cylindrical *Formers* by B and C, upon which (having previously greased them over with Soap) you fashion your *Boxes* just as you think proper, by pasting one Revolution of Paper upon another, turning round your *Former* which has an Axis at each End, suspended upon two Crutches, and having an Handle at one End to turn them round with. Being thus formed, put them to dry by a moderate Heat; for if you dry them suddenly by a brisk Fire, they will shrivel up: And therefore as soon as they are taken off from the *Former*, you immediately clap round Wooden Boards into them to serve for Bottoms, which are substantially glued into them, and afterwards nailed in from the Outside to fix them in still the more firmly. The Wooden Fuze belonging to the Bottom of each Box must be ordered and filled just after the same manner as we directed above for the fourth Sort of *Water-Globes*; and the *Rockets* shall be fixed after the same Fashion. Now, if you are desirous of seeing how all these *Cases* are adjusted and fixed in *Pyrotechnical Machines*, cast your Eye upon the *Statue of Fortune* which we have represented in *Fig. 202*, where you will see one of these distinguished at large by the Letter A.

S O R T II.

In the preceding Sort, I have given you a *Case* composed of several Pieces, which are destroyed and blown up by Degrees, as fast as the *Rockets* contained in one of them can force away the empty Box superincumbent upon them, which has already discharged its Load; but I here present you with some that are solid, and which always stand possess'd of their full Height; and only bear *Artificial Fire-works* on their Outfides, which being ranged in a continued regular Order from the Top to the Bottom, burn and fly up into the Air to the Astonishment of the Beholders: Or they contain *Artificial Recreative Globes*, and several such like Things which mount upwards to perform their Effects, and leave the *Case* empty: All these I shall entertain you with in the most perspicuous and concise Method I am able: First then.

Fig. 190

The *Case* or *Tube* which you see in *Fig. 190*, must be made of solid, hard, dry Wood, of what Height and Thickness you shall think proper. You must bore it with a large Augre to the Breadth of a Third or at least $\frac{1}{3}$ of the Solidity of the Wood. You must then divide the whole Height of it into certain equal Parts, which shall exactly correspond with the Height of the *Sky-Rockets* you intend to fix upon it, or they may be a little shorter. All these Parts shall be cut sloping in downwards, excepting only the uppermost which must be a Cylinder, but

but all the rest shall be Portions of a Cone reversed, so that the whole may be divided as it were into Joints like a Cane, and each Joint have a pretty broad Shoulder. These Shoulders must be flat, and have a Groove cut into them, and running all round them, which must be of a Finger's Breadth, and of the Depth of 6 Lines, or thereabouts. From these Grooves you must bore small Holes, by which the Fire may be conveyed to the Trains in them from the Body of the *Cafe*, to light the *Rockets* which stand upon them in Paper Cartouches, which must be securely fixed to the Wood to prevent them from flying away with the *Rockets*. As to the Construction in general of this, I shall refer you to our Chapter of *Water-Globes*, where you will find something of this nature in *Fig. 101*: But the Figure I have given of this, will sufficiently inform you of every thing relating to it, where A and B denote the Joints of this *Cafe* or *Tube* with their *Rockets*; C the great and small Cavities for your Trains; and D the Orifice of the Cavity in the Body of it. Your Trains in general must be of fine *Meal Powder*. But the great Boring which runs down the Middle of the whole (as well as of the rest which we shall describe hereafter) shall be filled with one of the *Compositions* we gave for *Water-Globes* or *Fire-Balls*: But I must caution you to put in about half a Pound of *Corn Powder* after every 5 or 6 lb of *Composition*, in order to clear and scower the Inside of the *Cafe* from the *Soot*, &c. which will stick to it, and suppress the Flame, and impede its lively Ascent. The Bottom of this Tube shall be solid and substantial; that is, you must not bore it quite through, but leave 3 or 4 Inches of solid Bottom to it.

S O R T III.

The Form of this *Cafe* in *Figure 191*, seems to differ pretty much *Fig. 191.* from the preceding; because this appears to be a perfectly round and uniform Cylinder; though in the main it is hollowed, and cut out in the same manner as that above. You are to trace out a Spiral Line from one End to the other of its Convexity; upon which Line you (at a convenient and equal Distance) are to cut out Mortesses or Holes to the Depth of two or three Inches, whose Bases and Perpendiculars fall obliquely upon the Axis and its Parallels: (See Letters B and C upon the same *Figure*;) Into these Mortesses you must contrive to fix Paper Cases with Wooden Bottoms, into which you may put any Sort of *Rockets* you please, as you see in A and E. But you must take care to have Fuzes or little Holes branching out from the Body of your great Tube to the *Corn Powder* beneath your *Rockets*.

S O R T IV.

Fig. 192. I can hardly add any thing farther of this to what I have already said above; for this *Cafe* is Cousin-German to the preceding one. However, there is this Difference between them; that the first is armed with *Rockets* which fly out of certain *Paper Cafés*; and on the contrary, this is surrounded with a Number of *Boxes* or *Cartouches* disposed in a Serpentine Order, like the first: Add to which, that they are secured as fast and firmly as possible by being glewed, nailed, &c. upon the Convexity of the great *Tube* or *Cafe*, and vomit forth a great Number of *Running Rockets* (or *Squibs*); and in a Word, their Position is Right and Parallel to the Axis and Sides of the Tube they belong to. As to any thing farther; this can boast of nothing that it has not in common with the other.

S O R T V.

Fig. 193. Divide the Periphery or Circumference of a Cylinder at each End into a certain Number of equal Parts, and then produce Subtenses or Chords successively terminating in your Points of Division. By this means you will have two Multi-Angular *Figures* (viz.) one at each End, whose Angles and Sides are mutually Similar and Equal. Thus taking the Sides of these *Polygons* for your Guides and Directors, cut away the Convexity of your Cylinder and convert it into a *Polyhedronic Prism*: If you have not a clear Idea of this, cast your Eye upon Fig. 193.

This done, bore it through the Middle with a large Augre, as we directed for the rest; and bore each *Hedron* or Side of it with a Number of Holes all falling obliquely, or at acute Angles, upon the Axis of the *Prism*, and the Plane of its Sides; all which must penetrate to the great Boring in the Middle. Into these Holes you must thrust *Iron Crackers*, or *Running* or *Sky Rockets*, if your Tube is in Proportion to them or can bear them.

The Tower which you see in the Middle of our Citadel fortified with 5 Bastions is built upon a Tube of this Kind, as may be perceived in Fig. 204. But the Ingenious *Pyrotechnist* may apply this to several other Uses, whether *Recreative* or *Warlike*: For my Part, I shall speak no farther of it, but proceed to give you an Account of others which I like full as well.

S O R T VI.

If you please to recollect; you may remember that I discoursed pretty largely upon a Tube of this Kind in *Book III*, when I described to you the Third Sort of *Sky Rockets*, and also in *Book IV*, when I treat-

ed

ed of the Twelfth Sort of *Water Globes*: So that notwithstanding I promised you then to amplify upon this in another Place, I find the Difference between those which I formerly described, and that which I have now taken in Hand, to be so very inconsiderable, that I can hardly distinguish one from the other, except it be with regard to Size, and therefore I shall refer you to what I formerly said to inform yourself in the Construction of this: However I must observe to you by the way; That all Sorts of Cases or Tubes (excepting that which we described First) may be filled after the same manner as what you see in *Fig. 194.* Where A points out *Pyrotechnic Stars* and *Sparks* interspersed with *Corn Powder.* B a *Recreative Globe* filled with *Paper* or *Iron Crackers.* C a *Light Ball*, or *Water Globe*, which of them you please. Finally, D shews you another *Recreative Ball* filled with *Running Rockets.* The Hollows and Interstices between these Fires are filled with a *Slow Composition* or *Corn Powder* to blow out the *Globes* &c. one after another.

S O R T VII.

Truly, I find nothing more troublesome, nor would there be any thing *Fig. 195.* more unprofitable than to coin new Words to describe each of these *Tubes*, since by the Construction of any one of them you may with a little Thought get the Knowledge of all the rest: Add to which, that the *Figures* I have here given you of them, illustrate them so evidently and plainly, that it is impossible for you to commit any Mistakes if you duly consider them. And therefore I shall add but two or three Words in favour of this Sort. Namely, that you are to fix all your *Crackers* upon the Convexity of it in a *Spiral Line*, whose *Revolutions* are pretty close to one another, and that they must be disposed in such Sort, that they may answer to the Form of a *Rhombus* composed of two *Equilateral Triangles*; or else *Saltier-wise*, or in Form of *St. Andrew's Cross.* Consider a little on what has elsewhere been said, and cast your Eye upon *Fig. 195.*

S O R T VIII.

Take a *Wooden Cylinder* smoothly turned, or let it at least be cut *Fig. 196.* out in a roundish Form, and let its two *Bases* or *Ends* be equal. Its *Diameter* or *Thickness* must be left to your own *Fancy*, but its *Height* or *Length* shall be always six times or ten times its *Breadth* or *Thickness.* This done; flute it as you see in *Fig. 196.* Now lest you might not know how this is to be done, I shall display it to you in few Words.

Divide the *Periphery* of the *Base* into 6 equal *Parts*, which you may do by taking the *Semi-diameter* of the *Cylinder*: Subdivide then each *Sixth* into 7 other equal *Parts*, and take one of these last *Parts* for the *Lift* or *Interpace* between the *Flutes* or *Channels*, and the 6 others

P p p p shall

shall be left for the Channels betwixt the Lifts. They are formed thus.

Take the half Breadth of each Hollow or Flute for a Semi-Diameter or *Radius*, and describe a Semi-Circle from a Point in the Periphery of your Base. Then skipping over $\frac{1}{2}$ for an Interspace or Lift, describe another Semi-Circle from the Periphery in the same manner, and so proceed till you have described 6 Arches. The same thing must be done at the other End or Base. In short, having produced Right Lines from one End to the other of your Cylinder terminating the Breadths of your Interspaces or Lifts, and your Flutes or Channels; hollow them in Proportion, and by the Direction of your Semi-Circles at each End, and the Lines upon the Curve Surface of your Cylinder. Then bore the Body of it from one End to the other, in such Proportion that the Diameter of the Boring may be $\frac{1}{2}$ or $\frac{2}{3}$ of the Breadth of one of the Hollows or Flutes wrought into your Cylinder.

Then prepare little *Mortars* after this manner. Get some Wooden Cylinders so as to fit each Channel or Flute; hollow them out, and add Chambers to them (as may be seen in B) which Chambers shall be $\frac{1}{2}$ or $\frac{2}{3}$ of your Flutes in Depth, and the Breadth of $\frac{1}{4}$ only. These Chambers are designed to hold *Corn Powder*.

Reinforce these *Mortars* strongly with Paper Cases on the Outside, and nail them fast in the abovementioned hollow Channels; whose Concavity they are exactly to fit; but as to the Length of them it shall be double of their Breadth. These little *Mortars* must each contain a *Recreative Globe* made of Paper, but with Wooden Bottoms prepared after the manner we formerly directed, and their Chambers must be charged with *Corn Powder*. Then having traced out a Spiral Line from one End to the other of your Case or Tube, fix these *Mortars* upon it, (that is) in a Spiral Direction with respect to each other, and secure them fast in your Flutes, by little Iron Staples driven into the Bottoms of them, and into the Sides of the Lifts or Interspaces, and bind the Middle of them with an Iron Plate fastened at each End upon the Face of the Interspaces: And if after having done all this, you apprehend they are not sufficiently secured, you may fix beneath them a Wooden or Iron Bracket. But before you thus fix on your *Mortars*, you must necessarily pierce little Holes into the Body of your *Case*, which must be filled with *Meal Powder*, exactly upon which you must place the Touch-holes of your *Mortars*. Every thing relating to this may be easily gathered from the *Figure*; in which A and B point out the *Mortars*, and C distinguishes the *Recreative Globe*. But here I must farther acquaint you, that there must be but one *Mortar* in each Channel or Flute. I shall not here repeat how you are to fill the Boring in the Middle of it, having mentioned it so often already.

C O R O L L A R Y I.

All these *Tubes* or *Cases* may be contrived so as to be portable after the manner of *Clubs*. And to that purpose you need only add an Handle or Gripe to them, that you may manage them without any danger to yourself, and at the same time destroy your Enemies: And upon this Account they may not only be ranked amongst *Recreative Fire-Works*; but may also be allowed a Place amongst the most Serious and Military, by filling them with something of a pernicious Nature and Effect, and arming them on the Outside with such Things as are proper to do Execution. This Hint I thought proper to make here; but I shall in the Sequel have a proper Opportunity of speaking more fully on this Subject.

C O R O L L A R Y II.

Though these 7 last great *Tubes* might very properly be filled with those *Compositions* we formerly gave for *Water-Globes* and *Fire-Balls*; I shall nevertheless subjoin the following *Compositions* for their Use, which will be particularly adapted to them.

I.

Take of Powder 12 lb; of Saltpeter 8 lb; of Coal 4 lb, and of the Filings of Iron or Hammer-flaw 2 lb.

II.

Take of Powder 24 lb; of Saltpeter 10 lb; of Sulphur 6 lb; of Coal 4 lb; of Colophone 2 lb; and of the Raspings or Saw-Dust of Wood 8 lb.

C O R O L L A R Y III.

In describing the above *Figures* we often made mention of an Helical or Spiral Line to be traced round the Body of a Cylinder; I therefore think it necessary to touch a little upon the manner of doing it; to the end that you may be enabled to succeed not only in the Construction of our Tubes and Cases; but also to perform several Things in Engineering, whether Mechanical or Hydraulical. Now having met with a Passage in *Vitruvius* which answers exactly to my purpose, whereby he instructs us how to make the Helical Screw, or Spiral Machine for raising Water, which is said to have been invented by *Archimedes* long enough before *Vitruvius* was born; I shall here insert it. Attend then to what he saith.

‡ *There is a kind of Screw which raises Water with great Power, but not to so great an Height as the Wheel. The Construction and Propor-*

‡ Vitruv. Lib. X. Cap. II.

tions of it must be thus ordered. Take a piece of Timber, whose Thickness or Breadth must be brought to consist of as many Inches as its Length does of Feet, and let it be made round. Divide the Periphery of it at each End into 4 Quadrants, or into 8 Semi Quadrants, by Radii or Lines branching out from the Centers, and terminating in the aforesaid Peripheries; and let these Lines so agree and correspond with each other that the Timber being fixed upright, the Lines of each Base or End may be exactly perpendicular over each other: From the exterior Extremities of these Lines (viz.) at each End, produce right Lines which may join them together, so that between these Lines thus produced there may be included $\frac{1}{4}$ of the Curve Surface of the Timber or Cylinder from one End to the other. Thus these Eight Spaces will be equal both in Length and Rotundity (or Breadth.) Being thus adjusted mark out oblique Lines or Diagonals between them, with Points upon each Line, continually following each other in an uniform Direction. The whole being thus ordered, take a thin Switch or Ruler of Willow, and anointing it over with Tar, or daubing it with any thing of that Nature, fix it in the Points of the First Diagonal, and from thence apply it to the Obliquities and Circuits of the other subsequent Diagonals. And thus proceeding on in a natural uniform Succession uniting and connecting the Points of your Diagonals together you will have your Helical or Spiral Line formed. And here you must observe that the more oblique your Diagonals are, the less frequent, and farther off will your Spiral Revolutions be from one another. Your Line being thus formed by an uniform Progression of Diagonals intersecting the Lines or Divisions of the Curve Surface of your Cylinder obliquely, hollow out a Channel in that Direction just after the manner of a Screw.

Thus far *Vitruvius* concerning *Archimedes's Hydraulic Screw*; but if it can be possible that the above Quotation is not plain enough to instruct you in the Operation, you may consult the *Commentaries* of *Philander* and *Daniel Barbarus* upon the same Subject, who have handled it with greater Prolixity.

Farthermore *Mar. Bettinus* in his † *Ærario Philosophiæ Mathematicæ*, or his Treasury of Mathematical Philosophy, has a particular Way of generating a Spiral Line, which is by some supposed to be invented by *Albert Durer*. The same *Bettinus* gives us another method of doing it, which he took from ‡ *Pappus*; where he explains the Meaning of *Vitruvius* in the Passage above-quoted: I have here then taken from that Author the most compendious Method I could possibly find to instruct you in the Subject in hand, after having retrenched some little Superfluities that could no ways answer our Purpose. Thus.

Let a Right Line be given equal to the Perimeter of a Cylinder, and upon one of its Extremities let fall or raise a Perpendicular; (which must be shorter or longer just as you propose to have the Revolutions of

† *Mar. Bett. Tom. I. Pag. 48. and 49.*

‡ *Pap. Lib. XIII, Coll. Mat. Prop. 24.*

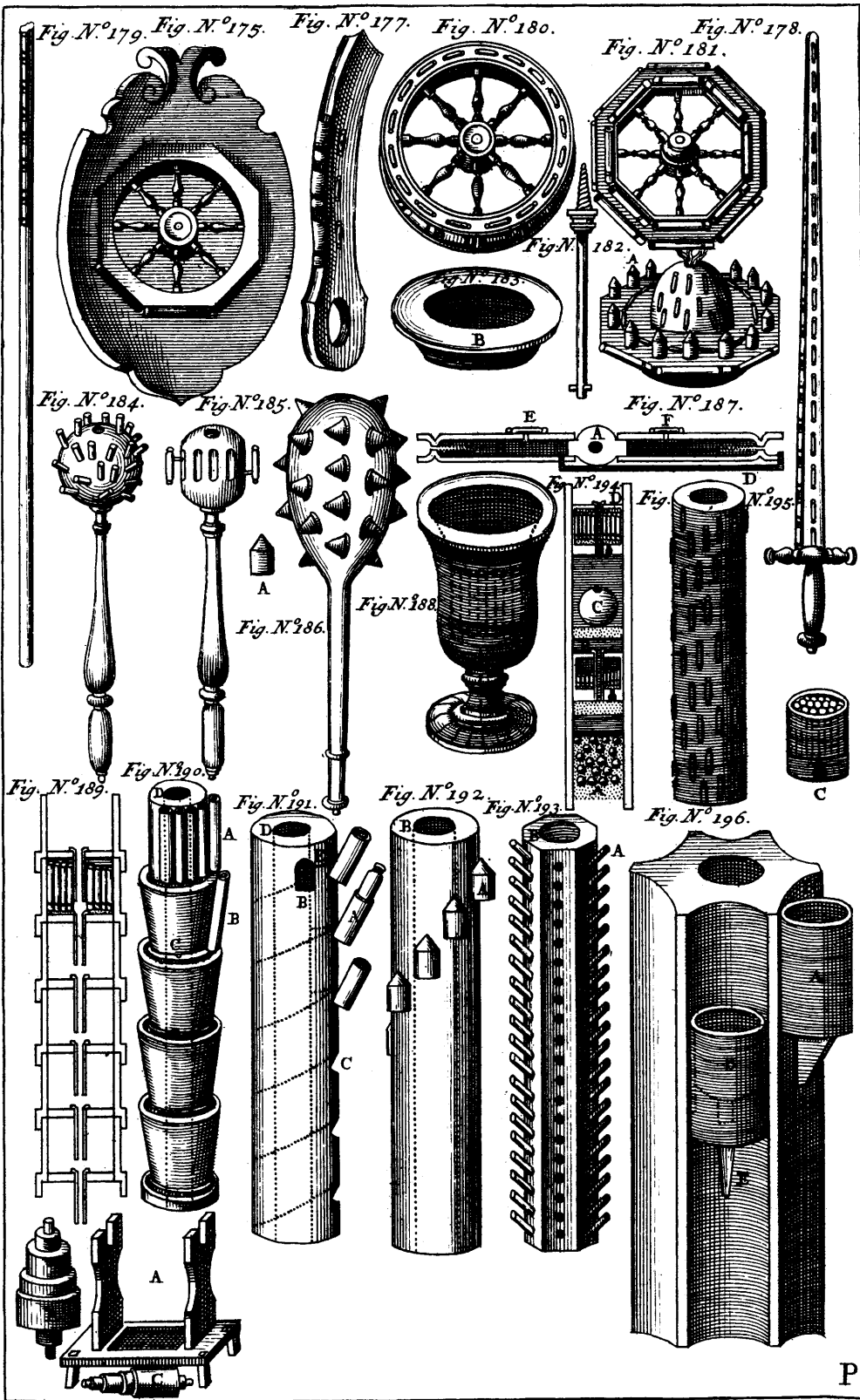

your Spiral more or less frequent) then from the Upper Extremity or Vertex of the said Perpendicular, produce an Oblique Line or Hypotbenuse terminating in the other Extremity of the Base or given Right Line: This done, cut out this Triangle in Paper; and by circumvolving or wrapping the Base of it round the Perimeter of the Cylinder, the Hypotbenuse by its oblique Embrace will circumscribe a certain Limit upon the Convexity of the Cylinder which will be your first Spiral; having then described it with a Pencil; apply your Triangle a second time for a second Spiral.

The Right-angled Triangle by its Base shews the Circular Progression of the lower Extremity of the Perpendicular: And the Perpendicular Side of it gives you by its Length the Progression of the other Point of the Perpendicular upwards during the Time it was surrounding the Periphery or Perimeter.

I shall to this only add that we might by this last method very conveniently and readily describe an Helical or Spiral Line, round the last great Fire Tube I gave you; (namely) by means of a Right-Angled Triangle whose Base is equal to the Perimeter of the Convexity of the Body, and its Perpendicular equal to the Height of it. Thus by applying such a Triangle upon a Tube or Case of the aforementioned Sort, the Hypotbenuse will make a perfect Spiral upon the Convexity of it, upon which Spiral you must range your *Mortars* in the Flutes or Channels wrought into the Surface of your Tube, and then secure them as we before directed.

From the same Author you may also learn a Method of describing a Spiral upon a Plane, which will be necessary for you to know, that you may be able to make the Serpentine Grooves in your *Artificial Shields* and *Escutcheons* as we said above.

C H A P. XI.

Of several Recreative Pyrotechnical Machines and Engines, composed of Rockets, Crackers, Globes, Wheels, Bucklers, Clubs, Symetars, Swords, Poles, Staves, Tubes or Cases, and all such like Artificial Fires.

ALL that we have hitherto said of *Artificial Recreative Fire-Works*, tends to this *Chapter* as to its Center: And all that we have hitherto taught in our Discourses on the Method, Order and Fashion of constructing all the foregoing *Fire-Machines*, has been no other than the Rudiments or *Apparatus*, to qualify or enable you to carry on and compleat the noble *Machines* exhibited on Popular Occasions; in short,

I have hitherto been only insinuating into you a Knowledge of the several Essentials, and furnishing you proper Materials to build with. In this *Chapter* I shall teach you the *Assemblage* of them, which is defined to be, *an ordering and disposing of the several Parts so that they may not hinder and embarrass one another; and the giving a Thing that Form and elegant Appearance which strikes the Eye of the Spectator in a pleasing manner.* Now this general Definition may be divided into several particular Branches, of which I shall here make Choice of two without specifying the rest which the *Architect* ought to be perfect Master of, and which the *Pyrobolist* ought not to be wholly ignorant in. The first then shall be the *Thematism* (from the Greek Word $\theta\epsilon\mu\alpha\tau\iota\sigma\mu\omicron\varsigma$) which signifies the *Decorum* and *Gracefulness* of any *Pile*; and is defined to be *the making the whole Aspect of a Fabric so correct, that nothing shall appear but what is approved and warranted by some Authority.* Now this last Quality of any Thing, is the Result of the profound Meditation, and assiduous Study and Diligence of the *Engineer*, in collecting all such Inventions and Contrivances as may be suitable to the Time and Place, where and when he exhibits his Work to the Public; and in accommodating them to the Rank of the Person by whom he is employed; in strictly keeping up to all such Things as seem to be in the most general Esteem amongst Mankind; in closely observing the Nature of Things; and in never attempting any *Chimerical* Impossibility, or ought else that might in any Degree shock and discompose the Rules of our *Art*.

The Second is *Oeconomy*, (from the Greek Word $\omicron\iota\kappa\nu\omicron\nu\theta\mu\iota\alpha$;) This consists in *actual Practice*, and in a perfect and mutual Connexion of *Members or Parts*; requiring the *Exercise of the Judgment*, and a Knowledge of *why*, and *how it comes to pass that any particular Thing ought to be placed here and not there; why This should be in one Position, and That in another.* It likewise considers *Times, Seasons and Expences.* And above all Things requires us to provide as much as we can towards our *Safety and the Preservation of Life*; and that, not with regard to ourselves only, but also with respect to those who might incur great Dangers through our *Misconduct and Imprudence.* These are the two *Pyrotechnical Topics* which I propose to enlarge upon, and entertain you with in the Sequel.

Of the Thematism, Decorum, or Gracefulness which is to be observed in the Ordering of our Recreative Pyrotechnical Machines.

Both *Ancients* and *Moderns* have allotted four general Times or Occasions for exhibiting of *Artificial Fire-Works.* The *First*: At the Consecrations, Inaugurations, or Coronations of Popes, Emperors, and Kings; at the Receptions of great Princes and Generals; and at the Elections of City Magistrates.

Secondly:

Secondly: Upon any Victory obtained by Land or by Sea; upon the Acquisition of any Province or City by Conquest; upon the Raising of Sieges, and all the happy Events of *War*. Again, upon the Conclusion of a Peace between two mighty States, and upon the Triumphant Entries of Emperors, Kings, and great Captains.

To this Class may be added Festivals, Anniversaries, and Canonizations of the Blessed; for I think it but reasonable that we should devote Days of Joy and Benediction, in Commemoration of those who have got the Victory over the World, by their Piety, Sanctity, Continnence, Christian Magnanimity, and all those Virtues which render the Soul beautiful in the Sight of God.

Thirdly, *Fire-Works* may be very properly exhibited at Entertainments and the Celebration of Marriages.

And *Fourthly*; upon the Merry-makings of Friends.

As to the *First* of these: It will be proper to prepare *Fire-Crowns*; to represent the Armorial Ensigns of Princes, Provinces, Cities, and People; to erect some Majestic Statue or *Colossus*, with a Number of smaller Figures about it, to personate the Subjects of the Prince, all dressed after the Fashion of their Country, and paying their Duty and Homage to their Sovereign by all the Postures of Submission. At the Inaugurations or Elections of Popes you may have recourse to the *Mythical Dream* of *Joseph*, (as we find it recorded in *Holy Writ*) wherein he saw Eleven Sheaves of Corn, which submitted to a Twelfth greater than They, and placed in the midst of them. For Emperors, you may represent the ancient Ceremony amongst the *Romans*, when they created their Emperors; which *Nicephorus Gregoras* mentions to this Effect. † *Theodorus upon the Decease of his Father was lifted up upon a Shield and acknowledged as Emperor; and Michael Paleologus was admitted to the Empire with the same Ceremony.* Julius Capitolinus saith: || *During this, Cæsar Gordanus was lifted up by the Soldiers, and saluted as Emperor. Ammianus Marcellinus* also in mentioning the Emperor *Julian*, who was raised to the Sovereign Dignity by the *Gallic* Troops; saith: *That being set upon the Shield of a Foot Soldier, and lifted up, he was in the midst of the silent Multitude proclaimed Emperor, and honoured with the Diadem.* We find also in *Ado of Vienna*, that this Custom was likewise observed amongst the *Gauls* at the Creation of their Kings; for he speaks to this Effect: *Sigisbert was put upon a Buckler after the manner of the Country, and proclaimed King in Prejudice of his Brother Chilperic.* And we find in *Aurelius Cassiodorus*, that this same Ceremony was in Vogue amongst the *Goths*; for speaking of it he saith: ‡ *That the ancient Goths, their Fathers, had created their Kings according to the Custom of their Ancestors, by lifting them up upon a Shield in the midst of drawn Swords.*

† Nic. Greg. Hist. Rom. Lib. III. Page 25. and Lib. IV.

|| Jul. Capit. in Max. & Balb.

‡ Aur. Cass. Lib. X. Var. Epist. XXXI.

This Ceremony, I say, may be properly applied to the Coronations of Crowned Heads: Representing the King or Emperor by a Statue made up of *Artificial Fires*, and elevated upon a *Shield*; which may serve as an *Hieroglyphic* to denote the Warlike Genius of the Sovereign, and his Invincible Prowess which had raised him to that sublime Pitch of Glory; or at least it may serve to admonish and excite him to an Acquisition of that Heroic Virtue which is so necessary for the Defence and Preservation of his Dominions. Or instead of this, He may be supported by the Armorial of particular Provinces and Cities, which will be the painted Voice, or perfect Representatives of the Will or Choice of the People; but in the ordering of this Article, our *Pyrobolist* must exert his good Sense and Judgment, by doing nothing that may shock or give Offence to the Constitution of the Kingdom. Or you might upon the same Occasion erect a Column, surmounted by an Imperial Crown or Royal Diadem with this Inscription *Currenti*, or *to the Foremost*. This Device alludes to an ancient Custom established amongst the *Poles*, after the Death of *Premislaus* or *Lescus* the First of that Name; for great Feuds arising amongst the Grandees of the Kingdom who contended for the Crown, and none being able to think of any Way of deciding their Pretensions, each of them persisting obstinately in his Claim; the whole Affair was thrown up to the Disposal of Fortune; and to that Purpose it was ordered that they should all appear mounted upon Horses, and ride a Race for the Crown of *Poland*, which should be conferred on him who first reached the Goal. Now to tell you by what Stratagem one of these Competitors, called *Lescus*, won the Prize; or to give you a particular Relation how he got Iron Bars laid under the Sand, to throw down the Horses of his Colleagues of the *Race*, reserving only a clear Path for himself, which he knew very well; I say, to dwell particularly upon this, is none of my Business; and those who would be farther informed upon this Head, may turn over *Martin Cromer's History* (*Lib. II.*) of the *Wars of Poland*. To this I shall only add, that such an Emblem may be applied to signify the Good Fortune of the Person raised to the Scepter or Crown; or to any particular Power over the People; but more especially if the King is proclaimed by the unanimous Consent and general Voice of the Nation, and as it were Elected preferably to a Number of Competitors who stood Candidates for the Sovereign Sway. This the prudent *Pyrobolist* will know how to accommodate or adapt to the State of Affairs.

Princes likewise may be very seasonably reminded at such Times of the Vicissitude of all sublunary Things, and the Incertitude of Prosperity, by a Sight of the *Wheel of Fortune*, which may be made after the manner of one of the *Wheels* we have given you above. This Emblem was exhibited lately at *Copenhagen*, at the Coronation of *Frederic* the present King of *Denmark*; and I think it very proper on such Occasions; for (as *Pythagoras* said) *Life is no other than a Wheel or Circle of Good*

Good and Evil. The *Wheel* then is a proper Emblem of *Fortune*; by which is meant *Divine Providence*; as we are taught by *Æsop*, who being interrogated by a Person, who asked him what *GOD* did? He replied (very much to the Purpose) *He abases the Lofty, and raises up the Humble.* To which we may add the following Words of the Sacred Text: *He hath put down the Mighty from their Seat; and hath exalted the Humble and Meek.* Again; remember the celebrated Sentence, which says, *That Human Things are a Circle.* And that other: *The Mutability or Vicissitude of Things is very pleasant to Man.*

You have for the same Occasions another Representation of *Fortune*, standing upon a Ball, and spreading out a Sail swelled by the Wind, and with her Hair flying about in *Fig. 203.* Thereby to signify to those Persons who are raised to the Honour of Governing, and bearing Rule over Nations; that their Happiness and Grandeur depend absolutely upon the *Divine Will*; and that they are changable and unstable like the Wind, very doubtful and of short Duration; and to warn great Men not to suffer themselves to be mis-led by the false Appearances of a flattering Fortune, but on the contrary, to preserve an Equanimity throughout their whole Conduct.

The *Figure* which we have given you in the Frontispiece of our *Work*, is a just Emblem of the Vanity of all Worldly Honours and Pomp; for what is a Man with all his Majesty, his Dignity and Power, but a Bubble formed and swelled out by the Breath of a Child, from a little Soap and Water? I say, he is even less to be considered than such a Bubble. You may then apply this to the Purposes above mentioned; and I cannot help thinking, that this Emblem drew its Origin from the Dream of *Constantine* the Emperor, just before the Turn or Change of his Fortune; wherein he thought, he saw a little Child taking very small Brittle Balls out of his Father's Breast; from whence he drew very melancholy Interpretations and Conjectures concerning the Misfortunes which soon after overwhelmed him.

When great Captains and Generals take the Field, with a newly-delegated Command over the Armies of the State, the ingenious *Pyrobolist* may apply to them the Ceremony of the *Roman* Chiefs of Old upon the like Occasions; which, according to *Servius Grammaticus*, was thus: † As soon as the Commission was delivered to them, they entered into the Temple of *Mars*, and first shaking the ‡ *Ancilia*, and then the *Lance of the Statue*, they cried out, *Mars vigilia; Mars, watch.*

As to the public *Entries* of Triumphant Emperors and Chiefs returned from War, you may represent a thousand magnificent *Fire-Works* proper to such Occasions. But were I to expatiate upon the several Particulars, I should spin this *Chapter* out to a very immoderate

† Ser. Gram. Lib. VIII. Æn.

‡ *Ancilia*, were a Sort of Holy Shields kept in the Temple of *Mars*.

Length: And therefore, though I have a very rich Field before me, I shall only gather some of the most remarkable and principal Flowers for you.

The *Pyrobolist* may then, upon such Occasions, represent every thing necessary or requisite in a Triumph: Such as Triumphal Arches, Pyramids, Obelisks, Trophies, Statues, Spoils of the Enemy, Colours and Standards of the Vanquished, the Captive Chiefs, with their Hands chained behind their Backs; together with the Inferior Prisoners all Dirty, Dejected, Squallid, and as it were half starved; and also the lively Representations of the Towns which are taken.

Again; you may prepare all the several Sorts of Crowns, such as (were formerly) the *Golden Triumphal Crown*, the *Civic Crown of Oak*, the *Mural Crown Winged*, the *Vallarine* and the *Obsidional*; and in short, the *Naval* or *Rostral Crowns* composed of the Beaks and Prows of Ships. But that our ingenious *Pyrobolist* may not wholly be a Stranger to the Pomp and Magnificence of the ancient *Roman Triumphs*, and that he may have proper Hints and Directions to work by, when Occasion offers, I have here transcribed what *Johannes Rosinus* and *Thomas Dempsterus* have collected of this Matter from several Authors concerning the *Roman Antiquities*. First then *Rosinus* saith: † *As to what immediately related to the Pomp of the Triumph it was much after this manner. The Emperor (according to ‡ Zonaras) being dressed in a Triumphal Habit, adorned with Bracelets, crowned with Laurel, and holding a Branch of the same in his Right Hand; he convened the People, and after having applauded his Army in general, and extolled private Merit in particular, he divided the Money and Spoils; to some he gave Bracelets, to others Spear-Staves, some were presented with Golden Crowns, and others with Crowns of Silver, on all which were inscribed the Names of the Persons; and the several Presents bestowed on them bore an immediate Relation to the generous and brave Actions they had performed. For he that had first scaled a Wall, had a Mural Crown given to him; if he had stormed some Castle, his Crown was suted to the Deed; if he had got the better in a Sea-Fight, he had a Naval Crown; and if he had behaved bravely in an Engagement of Horse, he was distinguished accordingly. But he that had saved a Citizen in Fight or in a Siege, or rescued him from any considerable Danger, was first extolled in the most grateful Manner, and was afterwards crowned with an Oaken Wreath or Garland, the Honour of which was reckoned vastly to exceed that of all Crowns whether of Gold or of Silver.*

Nor was Virtue rewarded in particular Persons only, but whole Cohorts and Legions were honoured with Presents and Marks of Distinction. Thus a great Part of the Spoils was divided amongst the Soldiery: There have been those who have made Presents to the whole Body of the People, and entertained them with Games at their own Charge; and if they had any

† Ros. Lib. X. Cap. XXIX.

‡ Zon. Lib. II.

thing left afterwards, they laid it out in erecting of Porticoes, Temples and other Public Works. Having dispatched this Business, and offered up a Sacrifice, the Triumpher ascended his Car, having thus prayed:

O ye Gods, by whose Nod and Command the Roman Empire has its Being and Increase, continue your favourable Protection of it, and preserve it.

Then he was drawn through the Triumphal Gate; being preceded in the first Place by Trumpets blowing Martial Sounds: After them came the Oxen designed for the Sacrifices, crowned with Wreaths and Garlands, and sometimes with gilded Horns: Then followed a magnificent Show of Spoils and Arms, which being piled with wonderful Art were partly drawn in Chariots, and partly carried by Youths richly dressed: Then succeeded the Titles of the Conquered Nations, and the Images of the Towns they had taken; and sometimes the Spoils were interspersed with strange Animals and Plants brought from the Conquered Country, and which had never before been seen at Rome: After these followed the Prisoners taken in War, the Captains and Chiefs of them being bound in Chains: And after them, immediately preceding the Emperor's Chariot or Car, were carried the Crowns of Gold, with which he had been complimented by Embassies from the Cities and Provinces, as was the usual Custom. Then came the Emperor himself in a sumptuous Car, magnificently habited, and shining in a Triumphal Robe, crowned with Lawrel, and holding forth a Branch of the same in his Hand. The Triumphal Robe was Purple wrought with Gold, of which Pliny Lib. IX. Cap. XXXVI, and Lib. VIII. Cap. XLVII. It was unlawful for any one to wear such a Robe as this any longer than the Ceremonies of the Triumph lasted, as we find by the History of Marius, of whom we read thus in Plutarch, (viz.) The Triumph being over Marius conducted the Senate into the Capitol, and whether he did it inadvertently, or whether he was elated by his Success and good Fortune, he had the Insolence to appear in the midst of them with his Triumphal Robe; but soon perceiving that the Senate took Offence at it, he rose up and laid it aside, without making the least Dispute about it. Dionysius Halicarn. speaking of the Embroidered Purple Robe usually worn by Kings, tells us, that it was unlawful even for Consuls to assume it any more than the Royal Diadem; for (says he) those Regalia or Ensigns of Royalty, were disallowed to the Consuls; because they were apt to raise Envy, and were seemingly inconsistent with Liberty: Indeed, upon Account of signal Services, such as the obtaining a Victory, the Senate consented that the General should be adorned with Gold, and clad in Purple. As for the Crown of Lawrel, you may consult Plin. Lib. XV. Cap. L. The Triumphal Car was in Imitation of a round Tower, and drawn most commonly by Horses, four in a Yoke or a Breast; but when Camillus in his Triumph assumed White Horses, he gave great Offence to the People, because they were particularly Sacred to the King and Father of the Gods. Some chose to be drawn by Stags, and others by Lions. Underneath the Emperor they hung the Idol Fascinus; of which

which Plin. Lib. XXVIII. Cap. IV. speaks thus :) *The God Fascinus was not only the Protector of Infants but of Emperors also; and by hanging under the Car defends it, and protects the Triumpher from Envy, and commands Respect to his Person; or it was applied to admonish him to look back upon himself, and consider that he was but a Man, though exalted to that high Pitch of Honour. Zonoras also saith, that a public Officer was drawn with him, who stood behind him holding over him a Crown richly adorned with Gems and precious Stones, and continually reminding him to look back upon himself, and consider what he was; and take Care of himself for the Remainder of his Life, and not be puffed up with Vain-Glory and Pride. To the Car they also hung a little Bell, and Rods or Scourges, by which was signified, that he might fall under the same Calamity, and might be torn with Rods, and condemned to Death. For he saith, that those who were condemned to any Capital Punishment for a notorious Crime, used to ring a little Bell, lest any one by touching them inadvertently should defile himself, and become a Sharer in their Guilt. Pliny farther saith Lib. XXXIII. Cap. VII. That it was the Custom for the Person who Triumphed, to paint his Face with Vermilion, as was done by Camillus, but this Custom was afterwards laid aside: And to have his little Sons in his Car, an Example of which he gives us in speaking of the Triumph of Æmilius. He likewise admitted his Kinsmen, if he had any, and his young Daughters into his Chariot. And those that were full grown, were set upon the Horses. Or if there was a considerable Number of them, they were drawn after him by single Horses. Close after the Emperor's Car followed the Army both Horse and Foot according to their Rank; and as many of them as had received Presents from him as the Reward of their Bravery and Courage, carried their Gifts in their Hands; the rest of them were crowned with Laurel, shouting with Triumphal Clamour, or chaunting Poetry upon the Occasion, or breaking Jest upon one another, or the Spectators. The numerous Croud of People which flocked from all Parts of the Town and Country to behold this mighty Procession were all decently habited, and mostly in White, joyfully congratulating each other, and applauding their Heroic Countrymen: And in Honour to the Gods, all the Temples were filled with Garlands and Crowns, and set open as the Pomp passed by. In this Order the Emperor being conducted in Sight of the Capitol, he at once guided his Car towards it, and at the same time ordered the Captives to be carried to Prison: Being come into the Capitol, he prayed to this Effect:*

I return thee my most sincere and hearty Thanks, O thou best and greatest *Jupiter*, and to thee O *Juno* his Queen, and to the rest of the Deities the Protectors and Inhabitants of this *Fane*, in that it has pleased you at this Day and Hour by my Hands and Actions to preserve the *Roman State*; Persevere in your Benevolence towards it as
you

you have hitherto done, cherish and prosper it, I humbly beseech you.

And then they offered up Sacrifices in the most solemn Manner; and consecrated Golden Crowns and rich Pieces of Armour to Jupiter, which they hung up in the Capitol. And in the same Place a Feast was given at the Public Expence, and Money distributed to the common People, Man by Man; and what was left, was laid up in the Public Treasury. And a little afterwards: They also erected Triumphal Columns, Statues, Arches, and Trophies, and other Monuments, as may be learned from Plin. Lib. XXXV. Cap. II. Of Triumphal Columns and Statues the same Author will inform you Lib. XXXIV. Cap. V. VI. and VII. and Valerius Maximus Lib. II. Cap. V. Georgius Fabricius speaks thus of the Triumphal Arches (in Roma sua Cap. XV.) Arches were formerly erected in Honour of those who had conquered Foreign Nations, or gained great Victories for their Country: At first, they were rude simple Piles, when the Rewards of Virtue did not stir up an unwarrantable Ambition. In subsequent and more imperious Ages they were embellished with the Ornaments of Sculpture. They were either of Brick, like that of Romulus; or of rough Square Stone, like that of Camillus; or of Marble, like that of Cæsar in the Forum; of Drusus with Trophies in the Appian Way; of Trajan, &c. The Arch was first Semi-circular, and afterwards Square as it went downwards, so that there was a vaulted Passage through it, and on either Side were added lesser Passages or Posterns. To the Vault of the middle Arch they hung Victory winged. Above this Vault there were Compartments or Pannels richly carved in Relief with Triumphal Representations. This Magnificence took Birth in the Reign of Augustus, or a little before.

Trophies were Trunks of Bodies, adorned with Military Ornaments and Arms, and sometimes with winged Victories, and a young Captive lying or sitting down before them with his Hands tied behind his Back.

Sometimes the Triumphant Chief was drawn to the Capitol by four white Horses, as was done in the Triumph of the Great Scipio; sometimes by Lions, as Marc Antony: Pompey the Great and Caius Cæsar by Elephants; Heliogabalus by Tygers, in Allusion to Bacchus; and by Lions, alluding to Mars; or by great Dogs by an unparalleled and not-to-be-imitated Example: Add to these the Triumph of Aurelianus Augustus, who to signify the Cowardliness of the Enemy was drawn by Stags; that of Nero, who was drawn by Hermophradite Steeds; and the Insolent Triumph of Susacus King of Ægypt, who was drawn by Captive Kings, as you may read in Josephus Book VIII. of his Jewish Antiquities Chap. X. Here you have Matter enough to employ your Genius and Art; on one Side, you may imitate the Sacrifices, on the other Side, all the magnificent Apparel of a Triumph, (*viz.*) Triumphal Arches, Pyramids, portable Statues, Trophies, Spoils of the Enemy, &c. All which you may dispose in graceful Order.

If these two Authors I have been now quoting have not said enough to satisfy your Curiosity; hear what *Appianus Alexandrinus* saith of the Triumph of the great *Scipio*: Being all crowned with Garlands, and preceded by Trumpets, they conducted the Chariots or Waggons laden with Spoils; they likewise carried Wooden Towers, Images, and Writings or Inscriptions expressing their fair Actions; after which came the Gold and Silver partly in rude Lumps and Masses, and partly wrought or coined; these were succeeded by the Crowns which had been sent by way of Homage or Acknowledgment; then White Oxen and Elephants; and after them the Numidian and Carthaginian Chiefs that had been taken in the War, who were succeeded by the Emperor's Lictors or Heralds richly clad in fine Purple; and after them a Croud of Minstrels and Singers after the Tuscan Manner, all crowned with Gold, playing and singing in regular Order; in the midst of these was a Buffoon adorned with Bracelets, and dressed in a long Gown trimmed with Golden Fringe down to the Ankles, who by his Gestures, Grimaces, and Ribaldry insulted the Prisoners, and excited the Laughter of the Spectators. Then came the Emperor himself surrounded by a Cloud of Incense and Odoriferous Perfumes; and drawn by White Horses, having Crowns on their Heads richly set off with Gems and precious Stones, and with Harnesses plated and studded with Gold; the Emperor himself sat exalted in a Gilded Car, habited in a Purple Robe after the Fashion of the Country, finely embroidered over with Golden Stars, holding in one Hand an Ivory Scepter, and in the other a Branch of Laurel; and accompanied by his young Relations, who were partly drawn with him in the Chariot, or laid hold on the Reins of his Horses; the whole Procession was closed up by the Body of the Army crowned with Wreaths of Laurel, some of them bearing Marks of Distinction as the Reward of their Bravery, and others stigmatized by way of Punishment for their Unworthiness; for as they knew how to applaud and distinguish the Brave, they also knew how to brand the Timorous and Unmanly with Infamy: In Allusion to which *Juvenal* has this Satirical Fling.

*Illinc cornicines, hinc præcedentia longi
Agminis officia, & niveos ad fræna Quirites,
Defossa in oculis quos sportula fecit amicos.*

In English:

Trumpets Before, and on the Left and Right
A Cavalcade of Nobles all in White:
In their own Natures, false and flatt'ring Tribes;
But made his Friends by Places and by Bribes.

The Triumphal Robe was either embroidered, or powdered over with Golden Stars, or else stained or wrought with Palm-leaves; from whence

whence it was called *Palmated*. *Lucan* speaking of these in *Book IX.* *Vers.* 177, sings thus :

————— *Pictasque togas velamina summo*
Ter conspecta Jovi.

Martial also mentions it *Lib.* VIII. and *Epig.* I.

Besides what we have here related, the Ancients used to carry the Names of Towns, Mountains, and Rivers in their Triumphs, together with solid Figures of Castles, Cities, and Towers, which were commonly of Massy Gold or Silver, and sometimes of Iron; but most commonly of Ivory, as we may learn from *Ovid* in *Lib. de Ponto Eleg.* IV.

Oppida turritis cinguntur eburnea muris.

In *English* :

The Ivory Towns begirt with Towered Walls.

And *Claudian Lib.* III. *de Laudibus Stilich.*

Ostentarent suos prisco si more labores,
Et gentes cuperent vulgo monstrare subactas.
Certarent utroque pares a cardine laurus,
Hæc alemannorum spoliis, australibus illa
Ditior exuviis, illic flavente Sicambri
Cæsarie, nigris hinc Mauri crinibus irent :
Ipsæ albis veberetur equis, currumque secutus
Laurigerum festo fremuisset carmine miles :
Hi famuli traherent reges, hi facta metallo
Oppida, vel montes captivæque flumina ferent.
Hinc Libyci fractis lugerent cornibus amnes,
Inde catenato gemeret Germania Rheno.

In *English* :

If still the Custom was in Pomp to show
The Victor's Glory, and the conquer'd Foe ;
The North and South wou'd equally combine,
To make his Valour and his Conduct shine.
Here, shou'd the Warlike German Spoils be shown,
And there, the richer Trophies of a warmer Zone.
Here, the *Sicambri* with their Golden Hair,
There swarthy *Moors* with jetty Locks appear.
He by white Steeds be drawn in Godlike State,
Whilst laurell'd Troops his Praises celebrate ;

Here,

Here, vanquish'd Kings be led with doleful Pace,
 There, Towns in Metal wrought, the Triumph grace;
 The captive Rivers and each captive Hill,
 In Model shewn, confess the Artift's Skill:
 Here, *Libyan* Streams shou'd grieve with broken Urn,
 There *Germany* in her chain'd *Rbine* shou'd mourn.

By this you may perceive that they used to carry the Images or Representations of Rivers laden with Chains, to signify their Servitude. *Ovid* speaks of this in *Lib. IV. de Ponto*.

Squallidus imittat fracta sub arundine Crines, &c.

The ingenious *Pyrobolist* may represent Rivers and Mountains also under Human Shapes in the most suppliant Postures saluting the Conqueror, and prostrating themselves at his Feet: The Rivers may be exhibited as presenting him with several Sorts of Fish by way of Homage; and the Mountains may offer him their several Sorts of Ores in little Cars; but I need not suggest any thing farther to a fertile Invention; for such will need my Assistance no farther than barely giving a few Hints of this Nature.

The Captives who were led in Triumph were chain'd by the Neck, the Arms, the Wrists, and Legs: That it was the Custom to chain them by the Neck, may be learnt from *Ovid's Art of Love*, Book I.

Ibunt ante duces onerati colla catenis.

In *English* :

The Chiefs shall march before, their Necks oppress'd with Chains.

As for the Handcuffs with which they used to secure their Prisoners; we are informed, that they used to fasten the Left Hand of a Soldier to the Right Hand of a Prisoner; that if the former made any Attempt to escape, the latter might have his Right Hand at Liberty to draw and use his Sword in case of need. *Statius Lib. XII. Theb.* ver. 470, speaks thus:

*Mæ Pietas me duxit amor deposcere sæva
 Supplicia, & dextras juvat insertare catenas.*

In *English* :

Thro' Love and Piety I met my Pain,
 And gladly gave my Right Hand to the Chain.

Tertul-

Tertullian mentions the Fetters for the Prisoners Legs, in *Lib. ad Mart.* where he says, That *the Leg feels no Pain when the Soul is in Heaven.*

And *Sid. Apoll. Carm. 2. vers. 179.*

Despiciens vastas tenuato in crure Catenas.

In *English* :

Despising pond'rous Chains which gall'd his meager Leg.

But what appears to me to be the most Shameful and Ungenerous of all, was their shaving the Captive Chiefs, as a Mark or Token of their Captivity; as *Propertius* observes in *Lib. IV. Eleg. 12.*

*Testor majorum cineres tibi Roma colendas,
Sub quorum titulis Africa tonsa jacet.*

In *English* :

Witness our Fathers Dust which we revere,
T' whom *Afric* yielded up her captive Hair.

Ovid also says something of it in *Lib. I. Amor. Eleg. 14.*

*Nunc tibi captivos mittet Germania crines,
Culta triumphatæ munere gentis eris.*

In *English* :

Now with new Arts, thou shalt thy Pride amuse,
And *Curls*, of *German* Captives borrow'd, use.

They likewise frequently drew their Warlike Machines in their Triumphant Processions; Witness *Tit. Liv. Lib. IX. Decad. III.* speaking of the Triumph of *Metellus*; and in *Lib. VI. Decad. IV.* describing that of *Fulvius*.

The ransomed Citizens, Neighbours, Relations, and Kindred, &c. followed promiscuously after the Triumphal Car with the Townsmen. *Valerius* says something to this Purpose, *Lib. V. Cap. II. (viz.) That 2000 Captives which had been sold by Hannibal, followed Titus Flaminus, &c.* These, according to the Testimony of *Tit. Liv. (Lib. IV. Decad. IV.)* were all shaved.

This is what I have thought proper to collect concerning the ancient Roman Triumphs, for the Use of our *Pyrotechnician*. I shall now touch upon *Mars, Bellona, Victory, Nemesis* and *Pallas*; all which may be

very properly introduced upon Popular Rejoicings on the Score of Warlike Atchievements, by adding to, curtailing from, or altering the several Circumstances belonging to them, according as Time, Place, Opportunity and Expence will allow.

The Ancients represented the God *Mars* as all Fire and Flame; sometimes drawn in a Triumphal Car, and at other Times advantageously mounted upon a Warlike Steed; here he bore a Lance in his Hand, and there, a Scourge. He was commonly attended by a Cock; thereby to signify, that Captains and Warriors ought to be perpetually upon their Guard, Vigilant in their Conduct, and Diligent in their Enterprizes. His Favorites and those who shared the most in his Esteem, were *Terror*, *Fear*, *Discord*, &c. as we find in *Homer*, *Iliad*. XIV. and *Virgil's Æneid*. VIII.

——— *Tristesque ex Æthere diræ
Et scissa gaudens vadit discordia palla,
Quam cum sanguineo sequitur Bellona flagella.*

In *English* thus :

The *Diræ* fowle from Heav'n with quick Descent,
And *Discord* dy'd in Blood with Garments rent,
Divides the Press : Her Steps *Bellona* treads,
And shakes her Iron Rods above their Heads.

Dryden.

And *Æneid*. XII.

——— *Circumque atræ Formidinis ora,
Iraque Infidæque, Dei comitatus aguntur.*

In *English* thus :

Wrath, Terror, Treason, Tumult, and Despair,
Dire Faces, and deform'd, surround the Car,
Friends of the God; and Followers of the War.

Dryden.

Statius enlarges his Train in *Book III.* of his *Theb.* ver. 425.

——— *comunt Færor, Iraque crispæ,
Fræna ministrat equis Pavor aliger, ac vigil omni
Fama sono, varios rerum succincta tumultus,
Ante volat currum.*

In *English* thus :

——— *Fury* and *Wrath* his Crest adjust,
And nimble *Fear* directs the fiery Steeds;
Whilst *Fame* flies on before to spread abroad his Deeds.

Some

Some have feigned that *Fear* drove the Chariot of this Warrior God.
Claudian in *Book I.* in *Ruffin.*

*Fer galeam Bellona mihi, nexasque rotarum,
Tende Pavor, frænet celeres Formido jugales.*

In *English* thus :

My Helmet let *Bellona* bring ; *Terror* my Traces fit,
And pannic *Fear*, do thou, the rapid Driver fit.

The same Author *de Laudibus Stiliconis.*

— *currum patris Bellona eruentem,
Ditibus exuviis tendentem ad sidera quercum
Præcedit, licitorque Metus, cum fratre Pavore ;
Barbara ferratis, innectunt colla catenis
Formido ingentem vibrat fuccineta securim.*

In *English* thus :

Laden with Spoils, the Plunder of the War,
Bellona swift precedes the cruel Car ;
Lifting on high an Oak conspicuous from afar.
His *Lictors* Fear and Dread with trembling Pace
Surprize and chain the rude *Barbarian* Race.
With haggard Looks, and Robes succinct *Affright*,
Wields an huge Pole-ax formidably bright.

Some Writers tell us that *Bellona* was the Sister of *Mars*, and others, that she was his Wife; and a third Class of them, assure us, that she was both his Sister and Wife. She was represented with her Hair disheveled, and spread over her Shoulders, with a Torch in her Hand, as appears by *Silius Italicus*, *Book V. Pun.*

*Ipsa facem quatians, ac flavem sanguine multo
Sparsa comam, medias acies Bellona pererrat.*

In *English* thus :

Her Torch *Bellona* waving through the Air,
Sprinkles with-clotted Gore her flaming Hair ;
And through both Armies up and down does fly.

Some represented her with a Scythe in one Hand, and a Shield in the other.

Victory

Victory was pictured under the Form of a winged Virgin, in act of springing up into the Air; bearing in one of her Hands a Branch of Palm, and on her Head a Crown. By the Wings of this charming Goddess, the Ancients gave us to understand, that the Events of War are doubtful and ambiguous; or that the Pursuit of the *Ambitious*, who are for pushing their Fortune to the utmost Pitch, is not so properly a Race, as a real and restless Flight: Or else they gave her Wings, to signify with what a sudden Swiftneſs she roams from Place to Place, from one Country to another to win the Ears and Hearts of Men. In Temples her Statue was usually supported by two others, who lifted and bore her up with their Hands.

Her Robe was either White, or dyed with Purple; for as this, is the Symbol of Majesty; that, is the true Emblem of Peace, and Hieroglyphic of the Joy she instils into the Hearts of those whom she pleases to favour.

Formerly likewise she was represented without Wings, and sitting upon a Ball. Some feign that by an extraordinary Prodigy the Wings of the Statue of *Victory* were burned by Lightning, which gave a Poet Occasion to say:

*Dic mihi Roma, alis cur stat Victoria lapsis
Urbem ne valet destruisse suam.*

And indeed, I think *Rome* was in the right to deprive *Victory* of her Wings, since it was a Means to prevent her from going elsewhere.

You may then make a Statue standing erect, and holding *Victory* in its Hands: By which upright Posture, will be signified; That the Conqueror was not an heavy indolent Person, or one who would suffer any Opportunity to slip by him, when he had a View of Conquest, or of snatching Palms and Laurels from his Enemies.

Nemesis was the Goddess of Vengeance, the Rewardress of Virtue, the Queen of Causes, the Sovereign Arbitress of Disputes and Disagreements; and was held by the ancient *Theologians* to be the Daughter of *Justice*. Her Statue also was winged, and trod upon a Wheel; because of the wonderful Swiftneſs of her Action. Sometimes she had a Bridle in one Hand, and the Measure of an Ell in the other. This may be very suitably applied, when any Prince or great Captain has obtained a signal Victory over Rebellious Subjects, the Violators of Peace, and Disturbers of the Public Tranquility; to the end that such Evil-disposed Persons may learn by this Emblem, That God is the sure and just Avenger of Crimes, and that he leaves no Perfidy unpunished; and be warned another Time, how they attempt to exceed the Bounds prescribed to them by Eternal Providence.

Minerva or *Pallas* is stiled by † *Cicero*, the Inventress of Wars.

† Cic. Lib. V. de Natur. Deor. Cap. XV.

She was pictured with a Pomegranate in her Right Hand, and an Helmet in her Left, according to the Testimony of *Celius*: For there are two Things which preserve a Republic (namely) The *Union* of Hearts and Minds, which is figured by the Grains in a *Pomegranate*: And, Readiness to defend it upon all Occasions, which is expressed by the Helmet. An Helmet born in the Hand, and not upon the Head, signifies; That a brave and generous Prince covers his Country, and not his Head; that is, That he protects his Subjects, and maintains the Public Interest jointly with his own, at the Hazard of his Life: And therefore it is, that in Physic Gardens you see a *Scipio* with a World at his Feet, covered by his Head-piece.

As much may be said of *Peace*; a Goddess to whom the Ancients consecrated the Olive-Tree: It was from hence that *Ovid* framed a pleasant Fiction in *Book VI.* of his *Metamorph. Fab. I.* Where he says, “ That a Contention arising between *Minerva* and *Neptune*, about giving a Name to the City of *Athens*; which put the Assembly of the “ Gods to a Stand, not knowing on which of the Two to confer the “ disputed Honor: *Neptune*, to win them over to his Interest, struck “ the Earth with his Trident, and caused a Horse to rise up from it: “ *Minerva*, on the other hand, having the same View with *Neptune*, “ caused an Olive-Tree to spring forth: These supernatural Productions being the Emblems of Peace and War, the Synod of Deities gave “ their Voices for *Minerva*, and so decided the Controversy.” By this Poetical Story we are given to understand, That Peace is infinitely more desirable than War; and that the Laws of the former are more pleasant and light, than the Yoke of the latter, which renders Life burthenfome and sad. You may have Recourse to this Emblematical Fiction, when any Prince has put an End to Wars, whether Foreign or Domestic, which had harrassed his Country, and oppressed his Subjects.

The Dove with an Olive-Branch in her Bill is a true Symbol of Peace; and indeed it is what the Sovereign Head of the *Roman Church* (*Innocent X.*) has chosen for his Armorial Ensign; from whence some Men conjecture that God will be pleased to re-unite the Christian Princes, under the Pontificate of this Spiritual Chief, and restore Peace to his People who have for so many Years past groaned beneath a Load of Misery; and who wish for no Favour with so much Ardency, as the Blessings of an universal Pacification.

Now with regard to the Olive, the *Romans* were wont to represent *Peace* with a Branch of it in her Hand; or else with Ears of Corn; and crowned her with Laurel. Sometimes Painters and Statuaries placed a Rose, and at other times a *Caduceus* or Wand in her Hand.

The greatest Attendant, and most intimate Associate of *Peace*, was *Felicity* or *Happiness*; who was pictured as a Woman seated upon a Royal Throne, holding in her Right Hand a *Caduceus*, and in her Left

a Horn of Plenty †. For it is most certain, That the true Happiness or Welfare of any State consists in a perfect Union between the Prince and People, and in the Fertility of Soil, which can never be so well cultivated as in Times of Peace.

These Statues may particularly serve by way of Decoration, to Triumphal Arches, and other Artificial Structures the Engineer may erect; Fig. 205. or they may be placed upon Pedestals, as you see in Fig. 205.

When any great Admiral shall have obtained a Signal Victory by Sea, you may represent a Triumphant *Neptune* upon the Water, drawn by Sea-Horses; crowned with a Naval Diadem; darting a Trident with his Left Hand; and in his Right holding a Ship, with her Sails set to the Wind; upon whose Prow, *Honour* may appear, under the Form of a Youth; decently clad; crowned with a Wreath of Laurel; and bearing a Scepter in his Right-Hand, and a Pike in his Left: *Virtue* also may be seated at the Helm, under the modest Garb of a Matron; tho' she was anciently represented by a young Man. *Neptune* may be on all Sides surrounded by a Number of Nymphs, Nereids, and Sea-Monsters, blowing in Conchs and other Sea-Shells, and in act of presenting Crowns to the Brave who thirst after Glory. In short, our Engineer will have a fertile Field before him, when the Celebration of such Occurrences requires him to bend his Invention this Way.

We are informed by History, That *Duilius* was the First of the *Romans* who triumphed for a Sea-Victory. *Valerius Maximus* tells us; “ † That whenever *Duilius* went to any Entertainment, he had a Torch, “ or some other Light, carried before him; and that, Supper ended, he “ returned Home with the same Equipage, and preceded by Trumpets “ and Minstrels; by which Nocturnal Ceremony he chose to express a “ remarkable Success in War.”

Upon the whole, you must know that *Neptune* obtained the *Watry Empire*, for his having been the first Inventor of Navigation, for his having built the first Ships, and fitted out the first Fleet, of which (say they) he was appointed Commander in Chief by *Saturn*.

But before I close up these Triumphant Representations, I cannot forbear entertaining you with a Description of that artificial and wonderful Piece of Machinery exhibited at *Paris*, upon the Victorious Return of His Most Christian Majesty *Louis XIII.* from the Siege of *Rockelle* in the Year 1628; and which was contrived by *Henry Clarmer* of *Norimberg*, one of the most celebrated *Fire-Engineers* of our Age, and whom we have taken an Opportunity of mentioning in the foregoing Part of this *Work*. *Paul Grodicki*, one of the best *Engineers* in *Poland*, speaks of it to this Effect. “ The *Artist* had raised an Artificial Rock in the “ middle of the *Sein*; which appeared inaccessible, for the Dangers “ which seemed to surround it; and frightful, because of its Precipices:

† Plin. Lib. XXXIV.

† Val. Max. Lib. I. Cap. VI.

“ To this Rock he chained a Naked Virgin, about whom were seen
 “ Nymphs running up and down in a confus'd Manner with lighted
 “ Torches in their Hands, and bewailing the rigid Fate of the Captive
 “ Maid. At length, there appeared a dreadful Sea-Monster, of enor-
 “ mous Gate, vomiting Fire and Flame in such abundance, and in such
 “ various Redundancy, that he was equally the Dread and Admiration
 “ of the Spectators : This prodigious Creature was carried by the
 “ Stream towards the Rock, with seeming Intention to devour the Vi-
 “ ctim designed for him ; but at the Instant he had reached the Rock,
 “ and was eagerly moving on towards his Prey, a young Heroe appeared
 “ in the Air, advantageously mounted upon a winged Steed ; who cow-
 “ ring down with the Reins upon his Neck, and fowling directly
 “ upon the Monster, the Heroe ran him through and through with
 “ his Spear ; and from the Wound there rush'd out a prodigious Quan-
 “ tity of Artificial Fires. In short, the Rock, the Monster, the Heroe,
 “ and the Maid, &c. were made up of *Artificial Fire-Works*, which
 “ plaid incessantly for several Hours. Amongst other Things, he re-
 “ presented the Arms and Name of the subjugated Town in Fiery Cha-
 “ racters ; together with the Royal Name of the King, and whole Sen-
 “ tences of Triumph and Glorious Import ; all which were seen scat-
 “ tered up and down in the Airy Expanse.”

This fine Piece of Machinery was derived from the Story of *Andromeda*, the Daughter of *Cepheus* and *Cassiope*, King and Queen of *Æthiopia*, who for her Mother's Pride and Vanity in boasting that she surpassed the *Nereids* in Beauty and Comeliness, was by them taken, and bound to a Rock to be devoured by a Sea-Monster ; but *Perseus* happily passing that Way in his Return to his own Country, delivered her, carried her away with him, and married her. *Propertius* mentions this in *Book II.*

*Andromeda monstribus, fuerat dedicata marinis,
 Hæc eadem Persei nobilis uxor erit.*

In *English* to this effect :

T' a direful Monster of the Ocean Stream,
Andromeda expos'd ; a helpless Prey !
Perseus the destin'd Virgin did redeem ;
 And bore the succour'd Maid his future Bride away.

It must be allowed, that the Thought of the Engineer, throughout this whole Piece, was extremely just and natural, and most pertinently adapted to his Subject ; for the King was represented by *Perseus* ; the winged Steed, or *Pegasus*, gave us to understand the martial and active Genius of that great Prince ; *Andromeda* was the true Type of the *Catholic*

tholic Religion, at that Time oppressed by the *Protestants* of *Rochelle*; the Rock bore allusion to the Town of *Rochelle* itself, and suited very well with the Etymology of it. In a word; the Monster destroyed, and Maid delivered by *Perseus*, figured to us, the *Restoration* of the *Catholic Church*, which had been doomed to Destruction by the *Protestants*, and the Suppression of their Heresy, and their Reduction to Servitude and Obedience.

This Fable may be very naturally applied, when any great Captain shall have compelled an Enemy to raise a Siege, and obliged them to quit any Place or Fortrefs, which they had obstinately attacked; and restored Peace to those who thought themselves upon the Brink of Ruin.

The conquered Cities may be represented by young Damsels, or venerable Matrons (provided the Female Sex agrees with the Name of the Place;) who may be placed in some great Gate-way, as it were saluting some Hero drawing near, and shewing him, how all the Gates are opened to receive him; that the whole Town is devoted to his Interest, and that he has nothing to do but to take peaceable Possession of it. This (as we are informed) was lately done at the Surrender of *Gravelines*, one of the prettiest Maritime Towns in all *Flanders*, which was besieged and taken by the Duke of *Orleans*.

But who is he that can give sufficient Instructions in any *Art*, to satisfy the entire Bulk of his Readers? Do we not see every Day New Additions and Improvements tacked to old Inventions? And what was unknown to our Fore-fathers is now so common amongst us, that one is almost ashamed to dwell upon it. In our Days nothing is acceptable but what is New, disregarding every Thing which has been formerly seen or performed. And therefore I shall have done with the Subject we have been here handling, and shall leave what else might be said of it, and whatever can be drawn from what I have here inserted, to the Fancy and Discretion of the Persons who are led by their *Genius* or Profession to cultivate our *Art*. Proceed we now to the *Vigils* or *Festivals*; and let us take in Hand the *Fire-works* which may be properly applied to the Celebration of those Solemn Occasions.

But I must here observe, that I believe our *Recreative Fire-works* and *Bonfires* derive their Origin from a certain Ceremony amongst the *Ancient Romans*, upon those Festivals which they held in Honour of their False Gods. I shall therefore here produce the Testimony of several Authors, for your Information in these Ancient Rites, and to illustrate the Pomp of their *Artificial Fires*; but before I enter upon this, I must premise a few Words.

The most famous of all the Games in vogue amongst the Ancients, were those which they called *Secular*: If you would know the Origin of them, you may consult *Valerius Maximus Lib. II. Cap. 4.* and other Authors. They were called *Secular Games*; because they were celebrated

brated once every Hundred Years, which they commonly computed to be a *Seculum* or *Age*. *Valerius Publicola*, who was the first Consul after the Abolition of the Kingly Government, was also the first that instituted and celebrated them. But the last that held them was *Septimius Severus* with his four Sons, all of them exalted to the Consular Dignity; for *Zosimus* assures us, they were never revived afterwards; because the End of the succeeding Age was ruled by *Constantine Christianus* and *Licinius*. But *Orosius Lib. VI.* *Eutropius Lib. IX.* *Zonaras Lib. II.* and *Eusebius Lib. VI.* affirm that the two *Philips* (the Father and Son, who are thought to have been the two first Christian Emperors) held them at *Rome* with a great Concourse of *Jews* above a thousand Years after the Foundation of the City. Pope *Boniface* was the First who in Imitation of the old *Romans*, instituted the Christian Secular Year, (which we now call the *Great Jubilee* :) This he did in the Year 1300, under the Reign of the Emperor *Albert*. (See *John Vall. Lib. VIII.*) After him Pope *Clement* the VI, at the earnest Sollicitation of the *Romans*, ordered the Mysterious Ceremonies of the *Jubilee* to return every Fiftieth Year, and accordingly began with the Celebration of it at that Term in the Year 1350, under the Reign of the Emperor *Charles* the IV. In short, Pope *Xyftus* the II instituted the Observance of it every 25 Years; which he confirmed by his own Example in the Year 1475, under the Reign of *Frederic* the III. To conclude, the *Roman Catholics* celebrate it this present present Year 1650 under the Pontificate of *Innocent* the X, at this Day the Head of the *Roman Church*, and under the Reign of the Emperor *Ferdinand* the III. Those who would know the Ceremonies usually practised in the Solemnization of this Mysterious Festival, may consult our famous Annalist *Paulus Piascius* Bishop of *Premislaw*, who was at *Rome* in the Pontificate of *Urban* the VIII, where he carefully observed whatever he saw worthy of Notice; but if you would have the freshest Accounts relating to this Matter, you may be informed by those who return this Year from *Rome*; for the Ceremonial varies considerably every Time. But let us now return to the *Secular Games* observed by the Ancient *Romans*; from whence to gather some Hints relating to the Decoration of our *Artificial Fire-works*. First then *Rosinus* speaks thus. † *The Time for celebrating the Games drawing near, Messengers were dispatched to all Parts of Italy to convene the People, and invite them to be present at those Games, which had never been seen before, and perhaps never would be seen again. Being then assembled, and the Festival near at Hand; fifteen grave Persons were presented to the Public, whose business it was to offer up Sacrifices in the Capitol and the Palatine Temple; and who being seated upon an Eminence, distributed the Offerings to the People; which were no other than Torches of Pine-Tree, Sulphur, and*

† Ros. Lib. V. Cap. xxi.

Bitumen; but Servants and Slaves were excluded from these Presents, and it was unlawful for them to accept of any. Besides the Places already mentioned; the People assembled in the Temple of Diana upon the Aventine Hill, where it was the Custom to give them Wheat, Beans, and Barley. Then they began to watch as usual in the Sacrifices and Rites of Ceres. The Day being come, they repaired to the Banks of the Tiber, where they remained three Days, and three Nights, wholly intent upon the Sacred Ceremonies. After these Preparations they offered up Sacrifices to Jupiter, Juno, Apollo, Latona, Diana, the Fates, Ceres, Pluto, and Proserpine &c. To this purpose the Prince upon the Second Hour of the First Night caused three Altars to be erected, upon which he offered up as many Lambs, and with him the Fifteen Venerable Men, and having sprinkled the Altars with Blood, they burned the Victims together. This done; they raised a kind of Theatre, and lighted up a great Number of Fires, Torches, and Lamps; and sang Hymns adapted to the Solemnity, and began to celebrate their Spectacles in good Earnest; distributing Wheat, Beans, and Barley, to those who acted the Principal Parts; as had before been done to the whole Multitude in general. On the Morrow they repaired to the Capitol, there to perform the usual Sacrifices; and then assembled in the Theatre, to see the Games in Honour of Apollo and Diana. Upon the following Day the Noble Matrons went up to the Capitol, there (at the Hour appointed by the Oracle) to pray, to frequent the Banquets, and to sing Hymns according to Custom. In short; upon the Third Day they convened in the Temple of Apollo, on the Palatine Hill, where Twenty-seven Boys in ceremonial Habits, and as many young Girls having both Father and Mother living, declaimed in Greek and Latin, and sang Pæans to the Immortal Gods, recommending to them the Safe-guard and Protection of their Empire and People.

As for the Decennia, which were Games instituted by the Emperor Gallienus to be kept every Ten Years; Trebellius Pallio speaks of them to this Purpose. After a pretty considerable Slaughter of Soldiers near Byzantium; Gallienus, as if he had done some mighty Feat, returned with the utmost Precipitation to Rome, and having convened the Senators; he celebrated the Decennia with new Sorts of Games, with a new kind of Pomp, and with the most exquisite Voluptuousness. He first went to the Capitol, attended by all the Senators, Knights, and Soldiery, in white Habits; these were preceded by an innumerable Multitude of Men, Women, Servants, and Slaves, with Wax Flambeaus, and lighted Lamps: On each Hand were led in fine Order, an Hundred White Oxen with gilded Horns, and adorned with rich Silk Housings and Trappings of various Colours. On either Wing also 200 white Lambs and 10 Elephants (which were then in Rome) and 1200 Gladiators magnificently habited under the Disguise of Matrons, all shining with Gold, together with 200 Beasts of Prey of several Sorts, finely adorned; Waggons full of Mimics and all kinds of Actors; Boxers, fighting sham Battles; Fellows counterfeiting the Cyclops:

clops: In ſhort, it was wonderful to ſee them, and nothing was to be heard upon the Way but Shouts and Clamour. The Emperor, in the miſt of all this, appeared with the embroidered Robe, and palmated Tunic, attended (as we have ſaid) by the Senators, Priests, Sacrificers, &c. in their ceremonial Habits. With this Equipage he moved on towards the Capitol, having on each Hand 500 gilded Spears or Halberds for his Body Guard; together with 100 Enſigns, and the Banners, Gonfalons, and Streamers, of the Colleges, Halls, Temples, and thoſe of all the Legions. To theſe ſucceeded a vaſt Croud of People, diſguiſed like Goths, Sarmatæ and Perfians, who marched at leaſt 200 in a Troop.

Theſe it muſt be owned were mighty fine Diverſions, and highly deſerving the Attention of ſuch great Men: But let them go on after their own Fancy without Contradiſtion; and let us leave it to the *Pyroboſiſt*, to pick and chooſe what can answer to his purpoſe from theſe Whims; whiſt we take another Subject in Hand.

As for the Feaſts or Revels of *Bacchus*, which were commonly practiſed in the Night-time; we find great Variety of them amongſt Authors; but particularly in † *St. Auguſtin*, who tells us in his *City of God*, That not only the *Romans* (who held theſe mad Frolics in great Veneration) but that alſo the *Grecians* obſerved them with the moſt horrid Exceſſes and Inſolencies imaginable; running up and down the Streets and public Places of the City, like Madmen, bearing Torches and Pitchers of Wine which they drank of without Meaſure; but for the other infamous Cuſtoms committed at that Time, I will not fully my Page with any Rehearſal of them. However, in proceſs of Time the *Romans* grew weary of them, aboliſhed them, and baniſhed them from their Republic, and enacted ſevere Laws againſt them, and ordained heavy Punishments to be inflicted upon thoſe, who ſhould ever attempt to revive them in any Part of their Empire. *Alexander of Alexandria* tells us ſomething of the ſame Nature, with Relation to the Games called *Floralia*; or which were celebrated in Honour of *Flora*.

Diana had alſo her Feaſt-Days, which commonly fell out upon the Ides of *Auguſt*: The Days dedicated to her, were obſerved with Torches, Flambeaus and other Lights; as we find in *Propertius*, *Book II. Eleg. 32.*

— *ſed tibi me credere turba vetat,*
Cum videt accenſis devotam currere tedis
In nemus, & Triviæ lumina ferre Deæ.

Ovid alſo de *Faſt.*

Sæpe potens voci frontem redimita coronis
Fæmina lucentes portat ab urbe faces.

† *St. Auguſt. de Civit. Dei, Lib. X. Cap. XLK*

In *English* thus :

Oft-times with Temples crown'd, and clam'rous Cry,
The Woman bears the flaming Torch on High
From out the City Gates.

The Ancients also did set Days apart in Honour of *Ceres*, whose Festival was solemnized with burning Torches; because she first undertook the Search of her Daughter *Proserpine*, who had been carried off by *Pluto* the King of Hell. *Lactan. Firm.* speaks of it to this Effect :
† *The Feast of Ceres was celebrated with burning Torches; because she is said to have lighted Torches on the Top of Mount Ætna, when she went in quest of her Daughter, who had been ravished by the gloomy God of the Infernal Regions.* Those who acted a Part in this Festival, ran about like mad People with Cresset-Lights of Sulphur and Dirt, as may be gathered from *Juvenal Sat. II.* and *Verf. 91.*

*Talia, secreta coluerunt Orgia tæda
Cecropian soliti Baptæ lassare Cotyto.*

Lucius Ann. Senec. also :

*Tibi votivam matres Grajæ
Lampada jactant.*

In *English* :

To thee the Grecian Matrons throw the votive Lamp.

Those who would be particularly informed upon this Subject, may consult *Stattius*, *Book VII.* of his *Theb.* *Verf. 412,* and the same Author *Book XII.* *Verf. 132.* *Claudian*, *Books II.* and *III.* *Mart.* *Book II.* *de Nupt.* *Ovid's Epistle II.* from *Phyllis* to *Demophoon*, &c.

To these three Festivals the *Athenians* added Lamps, which they vowed to *Panathenæa*, *Vulcan* and *Prometheus*. They held *Vulcan* to have been the first Inventor of *Fire*, and to have taught it the First to Men, as we are told by *Ister* in *Suidas* by the Word *λαμπας*®.

They not only used Torches and Flambeaus upon their Festivals; but also at the Initiations of all their Priests and Sacrificers; witness *Hesiod Lib. IX.* and *Juvenal Sat. XV.*

— *quis enim bonus aut face dignus;
Arcana qualem Cereris vult esse sacerdos.*

† *Lact. Firm. Lib. I. Cap. XXI.*

And *Statius* Book II. of his *Thebais*; towards the End of it.

*Tuque Actæa Ceres cursu cui semper anelo,
Votivam jaciti quassamus lampada mystæ.*

I will not here dwell upon the Festivals and Days dedicated to *Saturn*, which were also celebrated with Lights, as we are told by *Macrobius* †: But to all these we might add the Sacred Fires made of Straw, and lighted up by the *Savages* or *Barbarians*, over which they jumped three Times: *Ovid* sings thus with regard to this Matter.

*Tum licet apposita veluti crateræ camella,
Lac niveum potes purpureamque sapam
Moxque per ardentis stipulæ crepitantis acervos
Trajicias celeri strenua membra pede.*

This Custom has descended even down to our Days; for throughout all *Poland*, *Lituania* and *Russia*, and in all their circumadjacent Provinces, this Custom is religiously observed; and even in *France*, the Populace both Men and Women, Young and Old, assemble together upon the Eve of the Nativity of *St. John* the Baptist, and after having lighted up Fires in all the Cross-Roads, they dance about them, and jump over them in Token of Joy. ‡ The great *Olaus* assures us, that the same Custom was observed in his Time in *Sweden*.

But we have said enough of the Fires wherewith the Ancients used to celebrate their Vigils and Festivals. I might indeed enlarge considerably farther upon this Head, in Consideration, that we infinitely surpass the Ancients, not only in Artificial Inventions, but also in Piety and Religion; however, lest you should think I rather design here to write a Book than a Chapter, I shall take the shortest Way of handling it, by saying nothing farther of it. Upon the whole, I deem it high time to touch upon the *Artificial Fire-Works* which are usually practised at the Celebration of Nuptials, at Feasts, and public Assemblies, and Merry-makings of Friends, which are in the greatest Request at present: For to say the real Truth of the Matter, the People of our Age are so Close-hearted, and so Backward in paying the Veneration due to the great Author of all our Good, that we can hardly persuade ourselves to be at any Expence in the Celebration of Holydays and Seasons set apart for his Worship, in the Commemoration of his Saints; (God forbid it should ever be mixed with Superstition, feigned Devotion, or Pharisaic Vanity;) but on the other hand, we are so liberal in our Feasts, so profuse in our Superfluities, and so prodigal in all our Debaucheries, that nothing is too Good, nothing too Dear, for us to be-

† *Macr. Sat. Cap. VII.*

‡ *Ol. Lib. XV. Cap. IV. Hist. Gen. Sept.*

stow on the Gratification of our unruly Appetites. But if you are desirous of being furnished with Hints towards the Preparation of *Fire-Works* for the Celebration of Sacred Seasons and Occasions, you may consult the Holy Writers, in whom you will find an inexhaustible Fund of Mystical Treasures: And therefore, if you should ever have an Opportunity of exhibiting *Sacred Fire-Works*, you may have recourse to the Inspired Text, or consult those who alone have the Power of interpreting it, and of explaining the Mysterious Secrets, which the Divine Majesty has been pleased to couch under it. For my part, I shall pursue my Intention of treating on Human Vanities, by instructing you in the Construction of such *Fire-Works*, as are usually applied to Weddings, and the Carousals of Friends, &c.

We have the Testimony of many considerable Authors to inform us, That it was customary with the *Greeks* and *Romans* to solemnize their Marriages, and public Entertainments with Fires. We find their Poetical Works almost every-where interspersed with these Terms, (*viz.*) *Tædæ* or *Faces Jugales*, *Faces Legitimæ*, *Tædæ Geniales* & *Festæ*; that is, Nuptial Torches, Legitimate Torches, &c. *Claudian* sings thus, *Book II. in Ruffin.*

— *dilecta hic pignora certè*
Hic domus, hoc proprium tædis genialibus ornem.

The same Author again,

Cum tibi prodiderit festas nox pronuba tædas.

And in an *Epithalamium* of *Honorius* and *Maria*.

Tu festas Hymenææ faces ut Gratia flores
Elige.

Senæa the *Tragicomædian*.

Et tu qui facibus legitimis ades
Noctem discutiens auspice dextrâ,

Ovid also *Fastor. II.* and elsewhere.

Conde tuas Hymenææ faces, & ab ignibus atris
Aufer, habent alias mæsta sepulchra faces.

In *English* :

Go *Hymen*, stop the long-expecting Dames,
And hide thy Torches from the dismal Flames.

Thy

Thy Prefence would be fatal while we mourn;
And at sad Tombs must other Tapers burn.

Now in order to acquaint you, what the ancient Poets understood by these Fires and Torches; we will give you the Exposition of † *Festus* concerning it, (*viz.*) *Torches were carried before the Nuptial Pair in Honour of Ceres, and the Bride was washed with Water, that she might appear the more pure and chaste to the Bridegroom; or they thereby signified, that she was obliged to go through Fire and Water (as we have it in English) with her Husband.*

Lactantius Firm. gives us other Reasons for it, (*viz.*) ‡ *These two admirable Principles (meaning Fire and Water) have two Diametrically-different Properties and Effects, (viz.) Heat and Moisture, by means of which God produces and supports all created Beings. And a little lower: One of these Elements is as it were the Male, and the other, the Female; the one is Active, and the other Passive: And therefore it was that the Ancients introduced the Use (or Sacraments as the Original has it) of Fire and Water to ratify and confirm Marriages; and the rather, because every Thing that has Life is compounded of Heat and Moisture; and thus as every Animal is made up of a Spirit and a Body, the Body consists in Humidity, and the Spirit or Soul in Heat.*

The Wood of the Pine was the most frequently used for these Torches, witness *Ovid Book II. Pastor.*

Exoptat puros pinæa tæda Deos,

In *English* thus:

H' implores the Sacred Gods with Torches of the Pine.

Plutarch tells us they were ordinarily carried by five Youths amongst the *Romans*; but with the *Greeks*, the Bride's Mother bore them herself, as we are told by *Dempsterus*: But I shall dwell no longer upon this, and shall hasten to the *Pyrotechnic Works*, which may be properly applied to the Solemnization of Nuptials.

I need not tell you that Marriages are Seasons entirely devoted to Joy by the Friends of the contracted Parties, and celebrated by their Relations and Parents, &c. with certain mutual Liberties, and a thousand innocent Pastimes, Games, and Diversions, which are so peculiarly adapted to such Occasions, that it would be highly improper to practise them at any other Time. And therefore since all decent Liberties are allowed in this Case, the *Pyrotechnist* will have a notable Foundation to build upon. But here, if he would follow the most general Rules that

† *Fest.* Lib. VI.

‡ *Lact. Firm.* Lib. II. Cap. X.

have hitherto been laid down with regard to this Matter: He must give the first Place to Statues and Antics curiously wrought, with which he may adorn Fabrics, such as imitative Palaces, Triumphal Arches, Castles and Fountains, &c. Amongst other Decorations, he may represent a *Juno*, a *Venus*, a *Diana*, a *Cupid*, and all those lovely Deities, as well Male as Female, whom the blind Heathens held to preside over Marriages, &c. and whose Effigies you will find, or at least Descriptions of them, in the poetical Works of both Ancients and Moderns. Now that I may lend a helping Hand to those who have not the Convenience or Opportunity of reading such Books (which are not always to be had easily) and that our *Pyrotechnical Novice* may not be at a Loss, or be put to the trouble of unraveling the Intricacies of these poetical Fictions; I shall here undertake to lay before him whatever relates to this Matter in the clearest Light, and to illustrate it to him in the most lively and familiar Manner.

Juno, the Sister and Wife of *Jove*, amongst many other Appellations and Attributes bestowed on her, by her Votaries was called *Lucina*; because they imagined, she opened the Eyes of Infants, and administered Light to them as soon as born; from whence also she was called *Lucelia*. Or else she was called *Juno Lucina*, à *Juvando* & *Luce*, (that is) from giving or helping to Light; wherefore it was, that Women called out upon her in the Pangs of their Labour. She was also styled *Juno Jugalis*; either, because the wedded Couple were under one and the same Yoke, from whence the *Latins* called the Husband and Wife *Conjuges* or Yoke-Fellows; or because of the Yoke which was used at the Ceremony of their Nuptials.

Rofinus † describes her Statue thus: *She was represented by a Woman seated upon a Throne; holding a Scepter in her Right-Hand, and having a Diadem upon her Head, which was veiled in the Clouds; she was encompassed all round by Iris or the Rainbow, which was called Juno's Messenger; wherefore it was, that they figured the Iris, as a Maid-servant, ready to execute the Commands of her Mistress. She had Peacocks at her Feet, on each Side of her, which were particularly called the Birds of Juno.*

Diana, the Sister of *Apollo* and Daughter of *Jove*, was also called *Luna* and *Lucina* by the Ancients, who honoured her with many fine Attributes. They, amongst other Things, held her to preside over Births, and the Chase. The Women, as soon as delivered, sacrificed to her, and made Vestments for her. The Hunters celebrated her Festival in *August*, after a most pompous Manner with Flambeaus, and Torches, adorned with Ears of Corn, as we find in *Gratius's Cyngetica*.

*Spicatasque faces, sacrum ad nemorale Dianæ
Sistimus, & solito catuli velantur honore,*

† *Rofin. Lib. II. Cap. VI.*

*Ipsaque per flores medio in discrimine lucis
Stravere armâ sacris.*

She was represented under the Form and Meen of a Woman, with her Hair loose upon her Shoulders; armed with Bow and Arrow, and with her Forehead surmounted by a Crescent. Sometimes she was pictured in a Hunting Habit, in full Chase after a Stag.

Cleobulus tells us, That she having one Day desired her Mother to weave her a Gown; her Mother (knowing her natural Imperfections) replied; How is it possible for me to make a Garment to fit you, since your Form is so prodigiously given to Change? This may be very justly applied to Whimsical and Capricious Men, who are as unstable and various as the Moon; for in truth, they know neither Rule nor Measure.

Venus always shared greatly in the Veneration and Esteem of the Ancients, as she was the Goddess of Pleasure, Delight, and Generation. The Poets would make us believe, she was begot by a Spark or Seed of Fire which fell from Heaven into the Sea, and animated some of the Froth of that Liquid Expanse; thereby figuring (as *Varro* tells us) the great Power of Fire and Water when duly tempered together and united.

She was sometimes pictured as a young and tender Virgin, rising out of the Sea upon a Scollop-shell. At other Times she appeared as a perfect, mature Woman, holding a Conch-shell in her Hand, and having her Temples crowned with a Garland of Roses and other Flowers. The *Graces* attended behind her, and *Cupid* and *Anteros* were on each side of her. Here you saw her exalted in a Triumphal Car, drawn by Doves, in allusion to their Chastity; and there, by Swans to signify that Love is contracted by Blandishment, Candor, and Sincerity; or that the Votaries of that Divinity are always outwardly Neat, Polite, and Genteel, but that they are like Swans, Black within; or else, That forgetting they must die they sing like those Birds when on the very brink of Eternity.

Again; she was naked; to shew that an unbridled Voluptuousness divests us of our best Dress, and sends us away Empty-handed.

Phidias of *Elis*, that excellent Statuary, carved *Venus* with a Tortoise under her Feet (as we are told by *Plutarch* in *Præcept. Connub.*) to admonish Women by the Sloth of that Animal, to confine themselves to their Houses; and by the Silence of it, to learn Taciturnity.

The Lot which fell upon *Venus* at Play was formerly reckoned the most Lucky that could have happened (*viz.*) to have the Dies fall all upon one Side. This Statue then may be very proper in the public Congratulation of any Prince, who has enlarged his Dominions by a Happy Marriage, or by an Advantageous Alliance; not by the Assistance or Interposition of *Mars*, but of *Venus*.

Z z z z

Cupid

Cupid was the God of Love, of Luxury, and all sorts of Lasciviousness. *Servius* describes his Statue thus, according to *Rofinus*. “ He “ was represented as a Child; because he is no other than an intemperate Desire of Things unclean and immodest; and, because Lovers “ do nothing but fool away their Time like Children.

They gave him Wings; because there is nothing lighter than the Mind of a Lover, nothing more uncertain than his Vows; nor any thing more changeable than his Resolutions. They gave him feathered Darts in his Hand, to signify That the Sting of Repentance and Remorse of Conscience follow close at the Heels of the Pleasures of Love; Or else to shew the Doubtfulness of its Events, the Suddenness of its Course, and Shortness of its Duration. This obliged *Boëtius* to sing thus, in his *Consolation of Philosophy*,

*Omnis habet hæc Voluptas,
Stimulis agit fruentes,
Apiumque par volantum,
Ubi grata mella fudit,
Fugit & nimis tenaci
Figit ic̄ta corda morfu.*

In *English* to this Effect.

Love, whose Empire knows no Bounds,
Pleases first, and then he wounds:
Like the Bee, this Infant-King,
Has both Honey and a Sting.

Philostratus has ravishingly well expressed the Power of this amorous Passion. *Plutarch* calls him a *Dictator*, which was once the most Eminent Office in the *Roman State*; and others call him a *Soft Tyrant*.

He was formerly mounted upon a Lion, to signify that he tamed all Things.

Philippus feigned, That he had torn the Thunderbolts out of the Hands of *Jupiter*, that he had stripped *Apollo*; taken *Mercury's* Wings and *Caduceus* from him; disarmed *Hercules* of his Club, *Mars* of his Sword, *Bacchus* of his *Tbyrsus*, and *Neptune* of his Trident; meaning thereby, That none is able to withstand the powerful Impressions of Love. In truth, all these beautiful Fictions may be very naturally and gracefully introduced, in your *Pyroboic Edifices*, if you have Judgment sufficient to guide you in the proper Application of them to Times, Places, and Persons; but more particularly, upon the Marriage of some Brave and Generous Warrior, who till then thirsted after nothing but the Glorious Fruits of War; but is at length smitten by

by some lovely Beauty, and disarm'd by the Hands of an agreeable Woman, who shall enslave him under the Influence of Sacred and Legitimate Marriage. To these may be added the fabulous Story of *Hercules*, which tells us, he was so passionately fond of the charming Queen *Omphale*, that forgetting himself to be the mighty *Hercules*, he changed his Lion's Skin for the Effeminate Dress of a Woman; and employed himself in such Works as can only become the Fair-Sex; suffered his Mistress to put on his Martial Habit and Accoutrements; and what was farther extraordinary, was so complaisant as to take Blows from her.

Love was also painted as a Child, Bareheaded, and clad in a green Mantle, upon the Hems of which were seen these Words, *Mors & Vita*, or Death and Life, which are the usual Boundaries of this Passion, which for the generality runs into Extremes. Upon his Forehead he had this Device *Æstas & Hyems*, or Summer and Winter, signifying that Friendship and Love ought to be always the same, and equal in Adversity as well as in Prosperity. His Side was laid open over-against his Heart, where his Motto was expressed, *Longè & Propè*, or Far and Near; meaning thereby, that the Distance of Place from the Object beloved, is unable to disunite the Hearts of true Lovers.

The *Graces*, which the *Greeks* called *Charites*, tho' they had no immediate Power at Weddings; yet as they were the constant Companions of the Goddess *Venus*, I shall say two or three Words concerning them. They were represented by three beautiful young Women, holding each other by the Hand in such a Manner, that you saw only the back Part of the First, a Profil of the Second, and the Third turned her full Face towards you. *Seneca* explains this various Position of the *Graces* after a very Rational Manner in his Book of *Benefits*. Why (says he) are the three *Graces* said to be three Sisters, and why are they Hand in Hand? Some will have it, That the First is she who confers Benefits; the Second, she who receives them; and the Third, she who returns them; for it is certain that one good Action begets another; one Favour, draws Thanks after it, and a grateful Return of another Favour; and thus between Beneficence and Gratitude, you have a perpetual Circle of good Offices and Favours, reciprocally bestowed and returned. They have always gay smiling Countenances, to teach us, That he who either gives or merits a Benefit, ought to be always in good Humour, and distinguished by a serene Aspect, and particularly the Person who receives the Favour; because it is he alone that reaps the agreeable Fruit of Gratitude and Acknowledgment. They were young; because the Remembrance of good Offices ought never to wax old, or decay; and because they are always entire, disinterested, free from the sordid Views of Gain, or Expectation of a Return. They were pictured naked, to shew their Liberality and Sincerity; and were sometimes dressed in shining or transparent Robes, to remind us, That Favours and Benefits can never be concealed; but come to light sooner or later, to the great Honour of the Benefactor.

Amongst

Amongst these Divinities you may likewise allow a Place to *Bacchus*, who alone of all the Gods was admitted into Feasts and Weddings, where he most commonly presided, as may be gathered from these Verses in *Virgil Æn. I.* but we shall speak more at large of him in his proper Rank.

*Hunc lætum Tyriisque diem Trojaque profectis
Esse velis, nostrosque hujus meminisse minores.
Adsit lætitiæ Bacchus dator, & bona Juno.*

In *English*:

So may the *Trojan* and the *Tyrian* Line,
In lasting Concord from this Day combine;
Thou, *Bacchus*, God of Joys and Friendly Cheer,
And gracious *Juno*, both be present here.

Dryden.

Here I might introduce *Priapus* and *Flora* as Deities, which formerly assisted at Nuptials amongst the Ancients; did not common Decency restrain my Pen, and prevent me from putting my Reader to the Uneasiness of a Blush. And therefore, those who would know any Thing particularly relating to them, may consult others, who will inform them in what Posture and Fashion the Ancients represented them. However, that I may not conceal any thing from you, that Modesty will suffer me to communicate: They pictured *Flora* as a Nymph crowned with Flowers, of a comely, genteel Meen, and of a pleasant wanton Countenance. Those who would know any farther, may have recourse to *Pier. Valerianus* his *Hieroglyphics*; to *And. Alciat's Emblems*, and to the *Genial Days* of *Alexander Alexandrinus*, where they may be furnished with a vast Number of fine Hints for all Sorts of *Fire-Works*. I think it is now Time for me, to touch upon *Fire-Fountains*, which may be exhibited upon all Occasions, if the *Pyrobolist* thinks fit.

Whatever *Engineers* represent in *Water-Works* by Jets, variously disposed and contrived, may be exactly imitated in *Fire-Works*, as we shall hereafter evince. All those *Artificial Fountains*, whose Name and Invention we borrow from the *Italians*, may be very easily contrived to hold a Quantity of *Artificial Fires*; which may be play'd off in such Variety and Redundance, as to excite the Admiration of the Spectators. These will be the more surprizing and pleasing to the Eye, the more they are disguised, and the nearer they approach to a Resemblance of real Fountains for playing of Water; and by a little Industry and Art you may so order Matters, as to render it impossible for any one to guess by their outward Appearance, whether they be designed for Fire or Water: Therefore to carry on the Fraud the more speciously, you may fill some of the Basons of your Fountain or Fountains with fresh Water,
which

which may be thrown up by condensed Air, if your Fountain be small, or by a convenient neighbouring Fall of Water, if it be large; this may be done the more effectually to deceive the People, and to make them believe, that what they see is a real Fountain for Water.

Now in this Article, the *Pyrobolist* will have an Opportunity of displaying his Judgment, by adapting his Statues and Figures to the Nature of these *Hydraulic Imitations*. As for Example, he may represent a *Neptune* drawn by Sea-Horses; a naked *Arethusa* recumbent; *Nymphs* and *Nereids* swimming and floating upon the Surface of the Water, and playing with Sea-Monsters. Amongst other Things, *Helle* may appear upon a Ram, a *Siren* upon a Dolphin, and *Europa* upon a Bull; a naked *Naiad*, and the Story of *Aetæon*, who surprized *Diana* and her Nymphs when they were bathing themselves; or that of *Jonas*, who was thrown upon the Sea-shore by a Whale; and several other delightful Decorations which may be borrowed from ancient *Story*, whether Sacred or Profane. I shall hereafter specify in the most particular Manner, how all this is to be constructed. But tho' it might be necessary, that I should here (at least cursorily) touch upon the several Articles relating to *Nuptial* and *Genethliac Fires*, I shall desist, as apprehending that those, whose *Genius* is never so little Inventive, may form a thousand fine Pieces from the Hints I have above-given, which may equally surprize the Ear, and astonish the Eye. Let us now consider the fourth and last Sort of Occasions, to which *Fire-Works* may be properly applied.

And this is, when Friends meet together to enjoy themselves over their Cups, and in Scenes of Jollity and Mirth. I fancy, I need not inform you that *Bacchus* ordinarily presides over all such Occurrences, and that it is he, that bears the Bell away from all the other Divinities that might be introduced.

Therefore must we in such Cafes erect Statues to this *Jovial God*, and all his revelling Train; whom we shall here delineate to you from the same Authorities we have all along resorted to, for the Generation and Description of the other Deities here mentioned. I shall begin with this toying God himself, and collect the best Account I can of him, for the Instruction of our *Pyrobolist*.

Bacchus, according to the Testimony of *Diodorus* †, was the Son of *Jupiter* and *Semele*, and was bred up by Nymphs in the *Grotto* of *Nysa*, between the *Nile* and *Pœnicia*, from whence he was styled *Dionysius*. He was called *Bacchus*, from a certain Crown or Garland which he wore on his Head, and which was composed of Berries; or else (perhaps) from the Word *Bacchari*, which signified the Shouts and Clamour made by those who celebrated his Feasts. He was sometimes styled the *Liber Pater*; because he gives the free and unlimited Use of the Tongue; or because he frees from Trouble, and blots out the Re-

† Diod. Lib. V. Antiq. Cap. V.
A a a a a

membrance of Misfortunes and Miseries in those who are his hearty Devotees. Hear *Ovid*.

*Cura fugit, multo diluiturque mero,
Tunc veniunt risus, tunc pauper cornua sumit,
Tunc dolor & curæ rugaque frontis abit.*

In *English* :

Full Bowls dispel all Care, and Joy afford;
Then enters Mirth; the Beggar grows a Lord;
Then far away are banish'd Grievs and Fears;
No thoughtful Wrinkle in the Face appears.

But *Ausonius* has in a more particular Manner traced up his Genealogy, his Appellations and Attributes, in *Epigr.* XXVI.

*Ogygia me Bacchum vocat.
Osyrim Ægyptus putat.
Mystæ Phanacen nominant.
Dionysos Indi existimant.
Romana sacra Liberum.
Arabica gens Adoneum.
Lucaniacus, Pantheum.*

In *English* to this Purpose :

B' *Ogygia Bacchus* I am deem'd.
By *Ægypt Osiris* esteem'd.
The *Mystæ* call me *Phanaces*.
The Indians say I'm *Dionys'*.
Th' *Adonis* of Arabia.
The *Panth'us* of Lucania.
Me Rome, her *Liber Pater* claims.
To each a God, tho' call'd by diff'rent Names.

Here is a fine parcel of Names of very different Signification; and you may make him appear under the several Characters above-expressed in your *Artificial Works*.

It is the universal Opinion, that he was the Inventor of Wine, and that he was the first who cultivated the Grape; whence *Tibullus* says, *Book II. Eleg. III.*

At tu Bacche tener jucundæ confitor uvæ.

In *Engliſh* :

But thou O gentle *Bacchus*, Planter of the Grape.

Macrobius describes the Image of *Bacchus* to this Effect: † *The Liber Pater was represented as of an Age between Puerility and Virility; and ſometimes with a Beard as an old Man. On his Head he wore a Wreath or Garland of Vine-Leaves, Fig-Leaves or Ivy: Vine-Leaves and Fig-Leaves in Commemoration of the Nymphs Staphila and Syca, and Ivy in Remembrance of the Boy Ciffus, who was turned into that Plant. He was ſometimes drawn in a Car full of Vine-Brancheſ, by Pantbers, Tygers, or Linces. On one Side of him, you ſaw the good old Man Silenus mounted upon an Aſs, attended by a great Number of Satyrs armed with Thyrsi, and the reſt of the Bacchantes proceeding in a diſorderly March before and behind him.*

He was ſometimes pictured with the Breasts of a Woman, and with Horns and a Wreath of Vine upon his Head; mounted upon a Tyger; and bearing in his Right-hand a Bunch of Grapes, and in his Left, a great Pitcher to drink out of. Witness *Albric. de Imaginibus Deorum.*

He was Naked, to expreſs the Nature of Wine which can keep nothing a Secret.

And they mounted him upon a Tyger, to ſignify, That every Thing may be ſubdued by the Power of Wine.

Some ſay, he put *Lycurgus* to Death; meaning thereby, That Laws become ineffectual in ſuch Republics, as are immoderately addicted to drinking.

Dempſterus tells us, That *Bacchus* was alſo a Soldier, and that he made great Conqueſts in *India*. He writes thus: *The Thyrsus of Bacchus was a Spear twined round with Ivy, which his Army bore, when he led them to War againſt the unpoliſhed Indians.*

His Feaſts or Revels were always celebrated in the Night-Time with lighted Torches, as we have obſerved above.

The Companions of *Bacchus*, and thoſe who made up the greateſt part of his Train, were the *Sileni*, the *Satyrs*, the *Bacchæ*, the *Baffarides*, the *Lenæ*, the *Thyades*, the *Mimallones*, the *Naiads*, the *Tityri*, the *Nymphs* and *Faunes*.

Silenus, the Foſter-Father of *Bacchus*, was pictured as an old Man with a bald Head, and mounted upon an Aſs: Giving us to underſtand by the doleful Equipage of this Man, That Drunkenneſs transforms the wiſeſt Perſon into a Brute, and renders the fineſt *Genius*, and moſt comprehensive Wit, as ſtupid as the Beaſt on which he rode. Take the following Deſcription of him from *Virgil. Ecl. VI.*

† *Macrob. Lib. I. Saturn.*

— *Chromis & Mnasyllus in antro,
Silenus pueri somno videre jacentem;
Inflatum besterno venas, ut semper, Iaccho.
Serta procul tantum capiti delapsa jacebant :
Et gravis attrita pendebat Cantharus ansa.*

In *English* :

Young *Chromis* and *Mnasyllus* chanc'd to stray,
Where (sleeping in a Cave) *Silenus* lay,
Whose constant Cups fly fuming to his Brain,
And always boil in each extended Vein,
His trusty Flaggon full of potent Juice
Was hanging by, worn thin with Age and Use.
Dropp'd from his Head, a Wreath lay on the Ground. *Rafcom.*

It is of him that *Ovid* thus sings, *Met. B. IV.*

*Quique senex ferula titubantes ebrius artus
Sustinet, & pando non fortiter hæret asello.*

In *English* :

His Staff, does hardly keep him on his Legs,
When mounted on his As's ; see how he swags.

The same Author, *de Art. Am. Lib. II.*

*Ebrius ecce senex, pando delapsus asello
Clamarunt Satyri, surge, age, surge pater.*

In *English* :

Th' old Soker's drunk, from's As's h'as got a Fall :
Rouse Daddy, rouse, again the Satyrs bawl.

In the *Roman Games*, the *Sileni* wore long Robes or Mantles wrought with several Sorts of Flowers.

The *Satyrs* were cloathed in Goat-Skins, and had hideous Masks on. *Faunus* by the *Latins*, by the *Greeks*, *Pan*, was the God of Fields and Shepherds, and the Son of *Mercury*. He was pictured of a ruddy tanned Complexion; having Horns on his Forehead, and his Breast adorned with Rays. From the Navel downwards, he was all hairy and shaggy : He had Goat's Feet, and one of them was crooked. *Macrobius* mentions him *Lib. I. Saturn. Cap. XXIII.*

But

But to what Purpose should I perplex myself any farther, with giving an Account of *Bacchus* and his mad Attendants? Is it not enough, that I have pointed out to you the Places where you may have your Curiosity upon this Head fully sated? Let those therefore, who have the Leisure, turn over the Authors I have here quoted: As for me, I shall only give you some particular Instructions, concerning the *Decorum* and graceful Connection of our *Fire-Machines*; which done, I shall proceed to the *Oeconomy* and Distribution of them.

A D V E R T I S E M E N T I.

It will be no small Ornament to our *Pyrotechnical Machines*, if the *Engineer* has Art and Skill enough to introduce the Orders of *Architecture*; whether he would build a Palace, erect Triumphal Arches, Pyramids, Obelisks, Towers, Columns, &c. or only Parts of them: Or if he would prepare Fountains, or any other Pile, which must be regulated by the Rules of *Civil Architecture*. I am therefore of Opinion, that we should raise these *Ædifices* after the *Ionic*, *Corinthian*, or *Composite Order*. It must indeed be allowed, that the *Doric Order* is the most Masculine of all; and that it seems in itself to be the most proper for Triumphal Arches, Obelisks, Pyramids, and all such Pieces as are erected in Honour of victorious Chiefs; but the public Transport and Joy being boundless upon such Occasions, it has for the most part been thought, that nothing can be too pompous for the happy Victor: Wherefore these Triumphal Works require to be very elaborate; to be decked with all the richest Ornaments of *Sculpture*; and to have their Aspect perfectly magnificent. Things being thus, the *Composite Order* will answer your Purpose the best in all such Cases; for it carries with it a sedate Gravity, and an Air of Royalty, together with an incomparable Gracefulness; from whence it was, that the *Romans* had so often Recourse to it in Triumphal *Ædifices*; as may be collected from the Arches of *Constantine* and *L. Septimius Severus*, not to mention those of *Trajan* and other *Roman Emperors*, which *Onup. Panvinius* has remarked, to the Number of Fourteen; and which are for the most part entire at *Rome* to this Day.

The *Corinthian* and *Ionic Orders* will serve extremely well for Weddings and Birthdays; for they are perfectly delicate, and (if I may use the Expression) Effeminate; the First of them being compared to a fine young Lady richly attired, and the Second to a sober, reserved Matron in a modest Garb. These Orders also may serve for Holydays, and in the Celebration of Seasons set apart for Devotion. But by the way, it will be proper that all these Works should be exposed to public View in the Day-time; for otherwise to what Purpose would it be, to bestow so much Time, Labour and Cost, upon a Thing which is not to burn above a few Minutes, and that at a good Distance from the Spectators, and amidst the Darkness of Night?

B b b b b

Feasts

Feasts and Banquets also require the *Corinthian Order*; for upon such Occasions every one betrays his Luxury, Vanity and Prodigality, by all the Superfluities that can be devised.

The lowest, and most simple Orders, will always be best for Fountains, &c. such as the *Tuscan* and *Doric* intermixed with the *Rustic*; for it is proper, that they should have a rude and gross Aspect; but upon Occasions which require something more than Common, you may bestow what Embellishments you please on them; always keeping a strict Eye upon the Rules of *Architecture*. Or at least (if they should chance to be naked and plain) you may adorn them either with real or imitative *Rock-work*, according as either of them suits best with your Convenience.

A D V E R T I S E M E N T II.

All your additional Ornaments must be judiciously chosen, whether they be in *Relief* or in *Painting*; so that there may be no Incongruity or Dissonance subsisting, between the Nature of the Thing celebrated, and the universal Construction of your Machinery. Thus, upon the Inaugurations and Coronations of Kings, you may represent sacred Emblems and Stories: For Triumphs, Things of Victorious Import: For Weddings and Birth-days, you may introduce Scenes of Mirth and Gayety, such as Dances, &c. At Banquets and Caroufals, you may represent Fictions, expressing the mutual Joy and Caresses between Friends. At Coronations, you may adorn your Work with Royal Crowns and Scepters: At the Consecrations and Installments of Bishops, with Mitres according to their Rank; with the Armorials of particular Provinces and Cities; and with every Thing else, that bears Relation to the Quality of Persons preferred to any eminent Station in the Church.

As to the Ornaments necessary for Triumphal Works, you may be sufficiently instructed by *Trajan's Pillar*; which the *Roman Senate* caused to be erected in token of their Acknowledgement, and lively Sense of the great Merit and Virtue of that Emperor. *Geor. Fabricius* describes it thus: † *The Column itself is crusted over with Parian Marble, on which are expressed the great Actions of Trajan, and particularly the Dacic War. There you may see Representations of Fortresses, Bulwarks, Bridges, and Ships; together with the Employments of the Army; some sawing of Wood; some putting the Pieces of a Building together; some drawing out the Lines for fortifying the Camp; Pioneers at work upon the Trenches; some leading their Horses to Water; others carrying Trophies, and marching as it were in Triumph; as also Corslets, Helmets, Shields, and Bucklers, Belts, Clarions, Daggers, Javelins, Swords, Quivers of*

† *Geo. Fab. Rom. Cap. vii.*

Arrows, &c. On that Side, where the Inscription is wrought, there are winged Victories accompanied by two Eagles.

Prudentius speaking of Simmachus, has very naturally described the Triumphal Arches, and the Ornaments with which they were enriched, in these Verses.

*Frustra igitur currus summo miramur in arcu
Quadrijuges, stantesque Duces in curribus altis;
Fabricios, Curios, hinc Drufos inde Camillos, &c.*

By which he gives us to understand, that the Triumphal Arches were adorned with pompous Cars; in which were beheld the Statues of mighty Chiefs, such as the *Fabricii, Curii, Drusi* and *Camilli*; at whose Feet were Captives seen on bended Knees, and bound with rigid Chains.

To all this, we might add the several Sorts of *Military Garlands*, or the *Crowns* which we mentioned above; but the several Sorts of them must be most pertinently adapted to the Subjects celebrated; for Example; after a compleat Victory obtained in the open Field, you may use Crowns of Laurel; after the carrying of any Place by Storm, Mural Crowns winged: After a successful Combat by Sea, Naval Crowns: Wreaths of Oak, for those who have preserved their Fellow-Citizens: For a Siege raised, Garlands or Crowns made of the Flowers of the Field; and of Olive, for those who have restored Peace to their Country. To these may be added *Festoons* (so called from the *Latin Word Festivitas*, which signifies Mirth and Pleasantness) in token of Joy. Now, *Festoons* are certain Ornaments composed of an agreeable Assembly of Leaves, Flowers, Blossoms and Fruits. But you must take Notice, that in Triumphal Works the *Festoons* should be adorned with very few Flowers or Blossoms; but must be enriched principally with Fruits, intermixed with Leaves and Branches of Laurel and Ivy: You may also amongst your other Embellishments have single Branches, and Foliages of Laurel and Ivy, Olive and Vine, as it were negligently disposed of; but not at random, and in Places improper for them.

Upon sacred Occasions you may exhibit Cherubims, Palms, Pomegranates, Crosses, Stars, and Divine Emblems, representing Holy Mysteries; thereby to touch the Hearts of the Spectators, and beget in them Emotions of Piety.

The Ornaments and Embellishments proper for Machines erected for Weddings and Birth-days, &c. are Garlands of Roses, Lillies, Violets, and other Flowers; together with several Sorts of Fruits; such as Apples, Pears, Grapes of all Kinds, Plumbs, Olives, Medlars, Dates, Citrons, Lemons, Oranges, Pomegranates, Quinces, Melons, Cucumbers, and a thousand other Fruits; all which may be bound together in *Festoons*, interspersed with Leaves or Branches of Olive and Vine. These will have a most beautiful Effect in your *Pyrotechnical Works*.

You

You may have also little Birds curiously wrought, and perching upon Branches of Palm, or Bunches of Grapes; together with Horns of Plenty, Ears of Corn, Sheaves of Wheat and Rye, &c. Again; at Feasts and Caroufals, you may either paint or carve in *Relief*, Cups, Goblets, Flasks, Bottles, Flagons, Barrels, Tuns, Dishes of Meat, Baskets and Voiders full of Sweetmeats, Plates, Knives, and all the necessary Furniture of a Table; as also Musical Instruments, (*viz.*) Citterns, Guitars, Violins, Bass-Viols, Flutes, Cornets, Hautboies, &c. Upon the Celebration of Marriages, you may particularly introduce the Arms of the Bride and Bridegroom, which may be fixed upon the Frieze, (if your Piece be composed of Pillars) or upon the Shafts of the Pillars themselves, set off all round with Flowers, Foliages and Ribbons. As for the Art of making the Names of the married Couple appear in Fiery Characters in the Air, you may turn back to what I said in the *first Part* of *Book IV.* upon this Subject.

Your Fountains shall be adorned with all Sorts of Shells, and Stones of variety of Colours, little pieces of Rock-Work, glittering or transparent Stones and Pebbles, one and the other Coral, Splinters of Marble, and a thousand Things of that Nature, whether Natural or Artificial. To these you may add Reptiles and Insects of all Sorts, (*viz.*) Toads, Frogs, Serpents, Snakes, Lizards, Vipers, Grass-hoppers, Beetles, Flies, Ants, Crickets, Bees, Spiders, Snails, Horse-leeches, Cray-fish, and an infinite Number of other Creatures, which naturally haunt the Water, amongst which may be interspersed the several Sorts of Aquatic Herbs; together with the open Jaws of Lions and Bears. You may also represent several Animals, such as Hedge-hogs, Weasels, Rats, Rabbits, Hares, &c. together with Birds of amphibious Nature, such as Geese, Ducks, Teal, Storks, Swans, Swallows, &c.

A D V E R T I S E M E N T III.

The Garb or Dress of your Human Statues shall be chosen from the oldest Fashions that can be taken from the Monuments of Antiquity; for it must be allowed, that nothing pleases the Eye more, than the several Habits which were the Mode amongst the ancient *Romans*, &c. (*viz.*) the *Toga*, *Sagum*, *Prætexta*, *Trabea*, *Paludamentum*, &c. all which are still visible in what Reliques we have of the ancient Magnificence, whether Buildings or Medals. The particular Fashion and Uses of the abovementioned Habits may be found in *Nonius Marcellus*, *Justus Lipsius*, *Rosinus*, *Dempsterus*, and in others.

You may also cloath your Statues in the Skins of the Lion, Tyger, Leopard, Linx, Panther, Wolf, Bear, or such like Beasts of Prey; in Imitation of the Heroes of Antiquity, who clad themselves in the Spoils of those ravenous Creatures.

To all this, we might add the several Sorts of *Military Instruments*, which will be the more agreeable, the more they are conceived in the Guise, and bear the Appearance of rude Antiquity.

And therefore, I think it would be an ornamental Addition to our Works; if we painted or wrought in *Relief*, the *Fundæ* or Slings, the *Fustibuli*, Bows, Cross-Bows, Javelins, Lances, Spears, Partuifans, Pikes, Half-pikes, Axes, Pole-axes, Clubs, Swords; add to these, Shields; Bucklers, Targets, Corsets, Breast-plates, Cuirasses, Crests, Gantlets, Knee-pieces, and all the Pieces of Armour and Arms, which were in Use amongst the ancient *Romans*: You may also introduce the old-fashioned Fire-Locks, Bows, Arrows, and *Quivers* used by our Forefathers: All these will be very natural Embellishments, to Statues, Trophies, Triumphal Arches, &c. In sum, to express much in few Words; you must make it your utmost Endeavour to cultivate a Variety in all your grand Pieces, that you may never cloy your Spectators with an insipid Repetition: But on the contrary, let your Invention be perpetually on the Wing, that you may always have it in your power, to surprize them with something altogether new, perfectly natural, and judiciously understood: And thus by anticipating, or rather exceeding their Expectations, you may expect the public Applause in Reward for your Elegance and Industry; for tho' (as we are told by a considerable Author) *Things* done in the common Road may often administer Pleasure, they seldom or never excite the Admiration.

*Of the Oeconomy, or Distribution of Artificial Works, in
Recreative Pyrotechnical Machines; and of several other
Things relating to the same Subject.*

THE Explication of the *Thematism* or *Decorum*, necessary to be observed in our *Pyrotechnical Machinery*, has been considerably more prolix than I at first foresaw: But I hope to handle the Subject now entered upon, after a more compendious Method; and that, by means of certain succinct Rules, which I shall here lay down for your Instruction in the *Oeconomy* and Manual Practice of this Branch of our Art. They are thus:

I.

As soon as the *Engineer* has conceived a fine Thought for his *Pyrotechnic Works*, it will be absolutely necessary that he be able to express it in Drawing, the three Branches of which are *Ichnography*, *Orthography*, and *Scenography*. I say, it will be proper that he be a tolerable Master of *Design*; or at least, that he be able to sketch or *crayon* a little (as *Vitruvius* has it) that he may give the Person who employs him, a View of his intended Work upon Paper.

II.

It will not be enough, that he barely know how to sketch out his Design upon Paper; but it will be proper also that he be dextrous enough to make Prototypes and Models of it in Wood, Wax, Plaster, Paper, or Pafteboard, &c. fo that by this means any Deformities or Irregularities may appear obvious, and undergo a futable Correction, before he begins the Piece itfelf.

III.

As foon as your Design is brought to fuch a Point as to meet with Approbation; you are in the firft Place to confider the Charge and Expence allowed for compleating it; that you may be able to fquare your Work to your Purfe. You are then to treat with Workmen, whofe Affiftance you may ftand in need of, and contract with them for their Labour, and the Materials they are to furnifh you with. It is here that our *Engineer* will have an Opportunity of difplaying his Honefty, by fhewing how faithful and juft a Manager he can be of the Wealth of others: And it will be no difficulty for him to acquit himfelf with Honour in this Cafe, if he does not infift upon fuch Things as are hard to be procured, and confequently very chargeable; or if he has not his own Intereft, and fordid Lucre at Heart; or if with a View of future Presents from the Workmen, he does not fquander away what he is entrusted with, and what he will be obliged to render a ftrict Account of, if not in this Life, in the next.

IV.

Being entered in good earneft upon the Work, the *Engineer* is to take particular Care that the Workmen do their Duty to a tittle, and that they punctually obferve all the Rules of our *Art*, in the Conftitution of *Rockets*, *Crackers*, &c. to the end that the Whole may redound to his Credit, and have an Effect worthy of the Expence.

V.

The Carpenters fhall firft make the Carkafs or Frame of the whole Machine, with Timbers, anfwering to the Proportions of the Model which fhall be given to them: I here fpeak of large *Ædifices*, fuch as Palaces, Triumphal Arches, Towers and Castles, &c. for as to Columns, Pedeftals, Fountains, Obelisks, Pyramids, Human Statues, and Figures of Beafts; they all require to be conftituted after a particular Manner. Tho' the Order we are here fpeaking of, may be obferved in the Conftitution of fome of thefe laft, as may be remarked in the Re-

Fig. 197, and 198, prefentation of a Dragon in Fig. 197 and 198. In the firft of which you have a Sight of the Bottom-Piece or Foundation of the whole Figure, and the other gives you the Form of it, and fhews you the Order and Difpofition of all the *Pyrotechnical Works* withinfide. But as for grand and confiderable Machines, you may perceive the *Orthography* and *Scenography* of them, in the Rampart of a Castle diftinguifhed by A, in Fig. 204. It will be very eafy to erect Towers, whether round or many-

fided,

sided, Columns, and Obelisks (provided they are not very large) upon the Trunks or Stumps of Trees, or upon great round, or many-sided Blocks of Timber: These may be ordered much after the same manner with the Cases or Tubes which we touched upon in the foregoing *Chapter*: (Consider the *Figure* of the Tower Number 204; the Form of which does not vary much from the Case described and represented in *Fig.* 193.) Now the larger Sorts of these must be built with strong *Fig.* 193. Beams, Rafters, and Planking, which must contain within them a good quantity of Cases of Composition, and other Artificial Works: Add to these the usual Embellishments, (*viz.*) Pilasters, *Parastatae*, Architraves, Capitals, Pedestals, Columns and Pyramids, all which may be made of Boards, or at least formed of four, or more Spars, perpendicularly erected upon the Angles of the Base, or terminating in a Point at Top; (which is natural to a Pyramid;) after this manner you may make the Frames and Carcasses of Parallelopipeds, Polyhedronic Prisms or Pyramids, and then cloath them with waxed or pitched Cloths, or coat them over with Pasteboard: These may be filled with one or several Sorts of Cases, Sky-Rockets ready sticked, and neatly disposed in the Interstices between the Cases, and against the Sides of the Pile or Machine itself.

VI.

Human Statues, and Figures of Beasts may be ordered two Ways.

First, The Statuary or Carver must cut out the Bodies in Wood with all their Lineaments and Muscles according to the Proportions given to him, and according as he is directed, he must make them either naked or cloathed. Then taking them and anointing them over with Soap or Wax, they must be coated over with Pulp or Paste of Paper, kneaded or mixed up with Glue Water; which Coating shall be 2 or 3 Lines in Substance. It must then be dried by a gentle Fire, and as soon as the Skin or Coat is thoroughly dried, it shall be divided into two Parts, that is, it must be cut with a Knife close home to the Wood, on each Side from the Crown of the Head to the Soal of the Foot; and thus taking off this Pasteboard Skin you will have the hollow Image of a Man or Beast. In the several Cavities of it, shall be fixed one or more Cases of Composition, which must be previously shaped according to the Curvatures or Flexions of the Body, and well re-inforced or woulded to secure them from flying abroad, or splitting by the Violence of the Fire, before they have performed their due Effects; and it will be proper to fix them upon some firm Support, that they may be immoveable; which done, they must be hid in the before-spoken-of Paper Skin; taking Care to paste the Joints and Crevises very substantially together.

There are those who only inclose one Case within the Body or Skin, as may be observed in the Statue of *Fortune* in *Fig.* 202. But there are *Fig.* 202. others, who dextrously fill the Arms, Legs, Thighs, Hands and Feet with *Running Rockets*, or *Crackers*, or Cases of Composition curiously disposed

disposed of, and having Communication with each other by little Trains or Fuzes, so that they successively consume one after another. The Contrivance of this may be clearly observed in the Statue of *Bacchus* in Fig. 200. Fig. 200 : But I must here remind you that the whole must be fixed upon a solid Foundation, so as to be immoveable, and not be in a tottering Situation : Wherefore it will be farther necessary, that the Neck, Arms, Reins, Thighs, and Legs should be re-inforced with Iron Plates, or Rods, bent and turned, so as to humour and fit the several Angles and Flexions of the Body, according as the whole Frame of it leans more or less, and according as the Limbs are more or less contracted or stretched out. In short, the whole Inside of the Body must be strengthened with Iron Plates or Rods, if it happens to lean either Forwards or Backwards, to the Right or the Left. Now as to the Method of finding the Openings of the several Angles formed by the various Flexions and Curvatures of the Body, you may easily have them by the Assistance of a folding Rule, such as Carpenters and other Workmen use ; which Rule is in its general Construction very much like a *Sector*, which also may serve you for the same Purpose.

The second Way of forming Statues is thus : According to the Size or Form of the intended Body, they with a Number of such Cartouches Fig. 189. or Boxes I gave in Fig. 189, make the one half of the Statue ; that is, that Part which comprehends the Breast, the Back, the Belly, and others of the Inferior Members. Then with Boxes or Cafes of smaller Sizes, they form the Neck, the Head, the Arms, the Thighs, the Hands, the Feet, and all the Extremities of the Body ; bending and fashioning them at pleasure upon Wooden Balls filled with a *slow Composition*, and piercing them in two Places, just as the Fold or Curvature of the Limb requires : Into these little Borings they stick little Fuzes to give Admission to the Fire as fast as the Balls conceive it. All these Articles and Circumstances being duly observed, and cultivated, the Statue is covered over with some Cloathing of Cloth, or Canvass, or Silk, or (if you will) Paper, cut out, sewed together, coloured, and diversified, just as the *Engineer* shall think proper. To the Head of it, is added a Paste-board Mask, and Shoes, and Gloves of the same, are put upon its Hands and Feet ; in short, they endeavour as much as possible, that none of the Inside may appear in Sight. The Head of the Figure is commonly a Ball filled with *slow Composition* ; which Ball is sometimes bored in several Places, and especially when they would have a small *Fire Rain*, or long *Rays* to dart forth as from *Running Balls*. This I have represented

Fig. 202. to you in the Ball upon which the *Statue of Fortune* is fixed in Fig. 202.

But I must here strictly caution our *Pyrobolist* to take the utmost Care in joining and assembling the several Members of the Body, that they may be in no danger of being dispersed by the Violence of the Fire, and that the first that are enkindled may not tear away those which have

not

Fig. N^o 199.

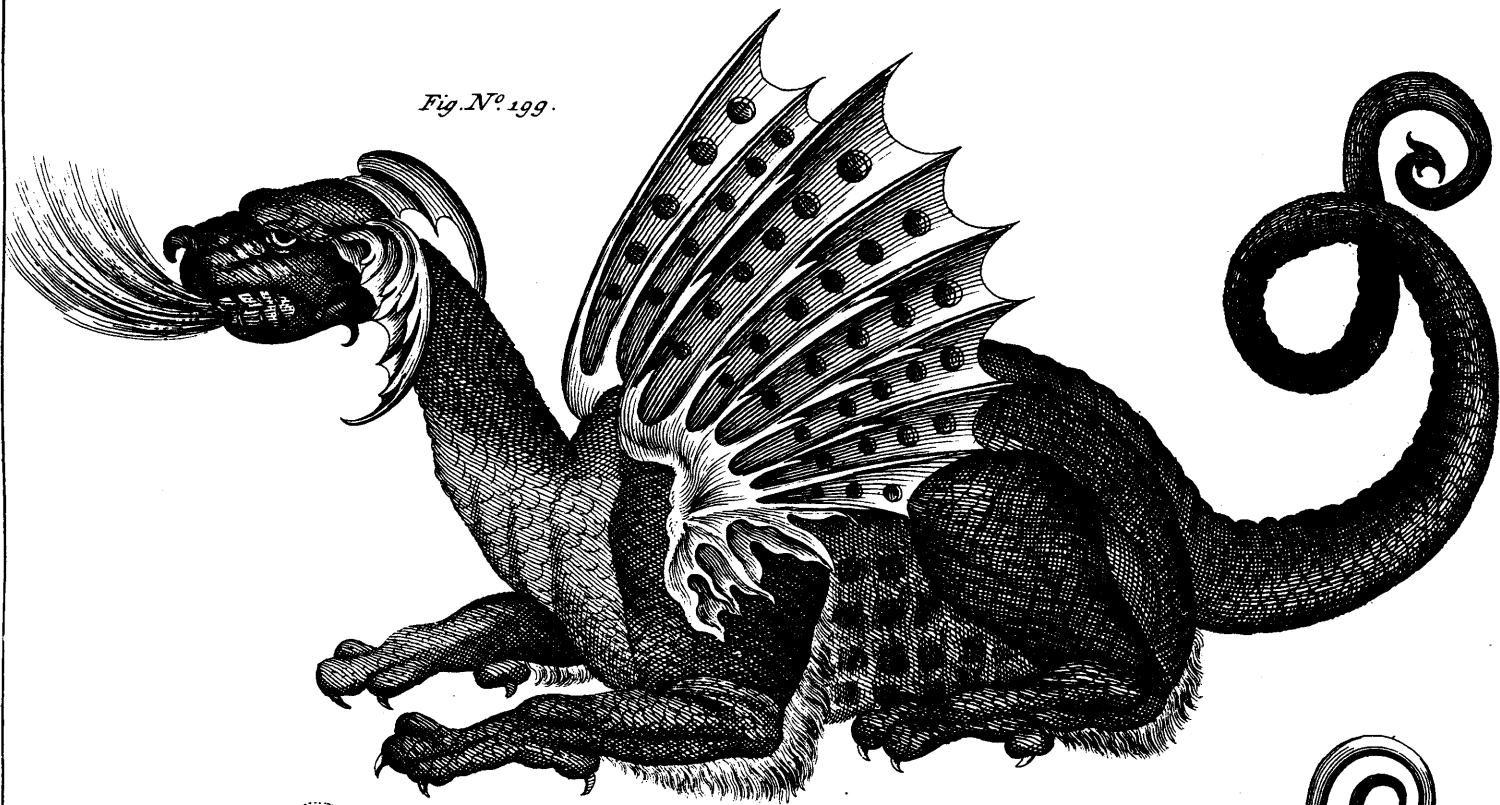

Fig. N^o 198.

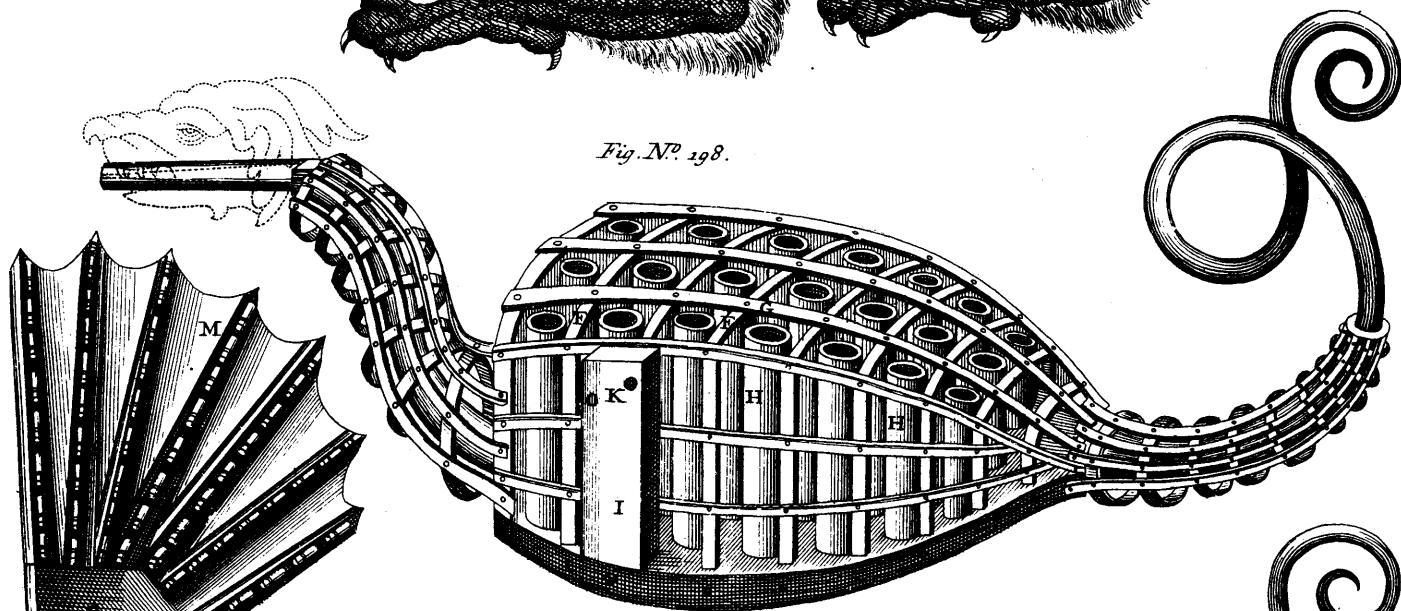
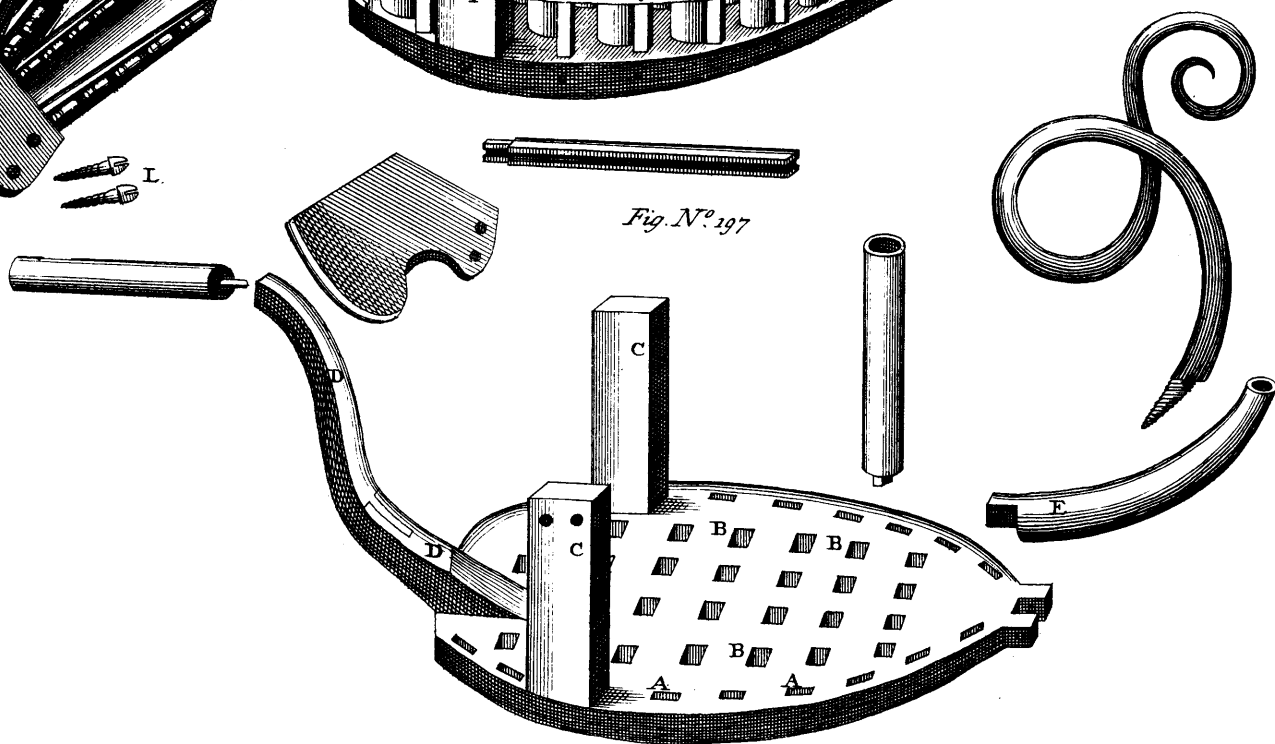

Fig. N^o 197



not yet been consumed; for otherwise your Work will have a far other Effect than you expected.

VII.

Whatever Animals you would represent, shall be cloathed in their own natural Skins, that approaching thereby the nearer to Nature, they may the better and more effectually deceive the Spectators. However; it will be in the first Place necessary, that you should cut these Skins to pieces, and sew them slightly together again with wide Stitches; to the end, that when the Artificial Fires inclosed in them would fly out, they may meet with no Obstacle of sufficient Force to retard, divert their Course, or repel them; but that with an Action free as Air, they may pursue their Effects, and burn and depart without the least Restraint or Opposition. The same Thing is to be understood of the Cloathings of Human Figures, be they made of what they will, whether Silk or Cloth, &c. particularly if your Fires are so disposed withinside as not only to rise up or burn out perpendicularly, but also obliquely to the Right and Left.

VIII.

Water-Globes must in like manner be covered over with Scales of Fish, and the Plumage of Water-Fowl.

IX.

The Coverings of Palaces, Triumphal Arches, Towers, &c. if they consist of Planks or Boards (after having been garnished withinside with several Sorts of Cafes of *Composition*, and other *Pyrotechnical Works*) must be armed on the Outside with Iron, or Paper *Crackers*; for which reason you shall make little Grooves or Channels in the Interior Surface of your Planks, &c. in which you may lay Trains of *Quick-Match*, or of some *Composition*, and fix *Crackers* upon them after the manner I taught you above, when I treated of Shields and Bucklers, and in the same Order, as may be observed in *Figures 200, 202 and 204*, by the Letters B, C and F. Fig. 200,
202, 204.

X.

To give you a general Rule for your Instruction in the Beauty and manual Practice of this *Art*, I can only tell you; That every Part either within or without your Machine, or that is in any wise dependent upon it, must be composed of some Kind of *Fire-Work*: Wherefore all the Beams, Rafters, Transoms, Planks and Boards; Capitals of Columns (if there be any) the *Parastatae*, the Lifts, the Flutes, Cornices, Friezes, Architraves, Modillions, Dentils, Tryglyphs, Drops, Metops; in short, the Plinths, Pedestals, Apophyges, Bases, and all the Enrichments and Decorations, such as Wreaths or Garlands, Foliages, Festoons, Fruitages, Leaves, Flowers, Antics, Coat-Armours, Shields, &c. must all consist either of *Crackers*, *Stars*, *Sparks*, *Rockets* of all Sorts, or of little *Hobbits* charged with the various Kinds of *Fire-Balls*. As for the Manner of constructing Basons with their Pedestals, and the Method

D d d d

thod

thod of ordering the Steps of Fountains, and garnishing them with *Rockets* or *Crackers*; it may be easily learned from the *Figures* distinguished by C and D.

XI.

You must fix some of your *Iron Crackers* obliquely, and others perpendicularly to the Horizon, but their Vents or Fuzes shuft be turned some Upwards, and others Downwards; some to the Right, and others to the Left: Thus will they be alternately and diversly disposed. You must take particular Care, that your double and triple *Crackers* be all fixed perpendicularly to the Horizon.

XII.

Now as no particular Sett of Things meets with Approbation from all Sorts of People; and since what pleases one disgusts another; and in Consideration that our Works are not designed to administer Pleasure to a few Persons only; but are to undergo the rigorous Scrutiny and Examination of a Multitude, whose Tastes it will be necessary for our *Pyrotechnician* to consult (provided that the Bulk of his Spectators are of sufficient Capacity, to judge aright of his Work; for otherwise it would be better to please a few Persons of sound Sense and Knowledge than thousands of the Ignorant and Vulgar.) I say, these Things considered; it will be very proper to intermix your *Crackers* with *Rockets* of several Sorts, and other *Pyrotechnical Inventions*, which from time to time, and at suitable Intervals, may depart, fly up, and perform the Effects natural to them, thereby to increase the Diversion, and avoid Scandal. Furthermore, if the *Engineer* thinks proper, or if it be the Will of the Person or Persons he is employed by, to have several Fires break out at once, and to have the Discharge of *Crackers* more frequent than is customary; there shall be a good Number of Vents made in several Parts of the Machine, through which the Fire may be introduced whenever you please into the Works contained in the Body of the Fabric: For there are those who usually make but one Vent, and that, upon the Top of the whole Pile; by which means the whole Body of it is consumed successively, and by Degrees: But this must be left to the *Engineer*. This way of giving Fire to our Machines, must be owned to be very Artificial; but the other is more certain and less dangerous.

XIII.

Fires of various Colours are held in great Esteem with regard to these Works; as if, for Example, you would represent a *Rainbow*, an *Infernal* or *Gloomy Fire*, *Water*, *Stars*, and such like: But having handled this when we spoke of *Sky-Rockets*, our *Pyrotechnician* may turn back to that Part of our *Work*, where he will meet with sufficient Instruction upon this Head. Again; you must contrive to have imitative Lightning, or some extraordinary Flashes or Glares, which will vanish as soon as seen. This may be easily done with a little yellow *Amber* or *Colophone*, *Gum Juniper* or *Ship Pitch* well pulverized or mealed.

XIV. If

XIV.

If the *Engineer* by his *Artificial Fountains* would represent a Cross, a Star, a small Rain, a Rainbow, or any Thing else of that Nature, he must get Clay Pipes made; (for our *Compositions*, however *slow* they may be, will melt any sort of Metal by means of the *Sulphur*, *Salt-peter*, and other hot and violent Ingredients they are compounded of;) these Pipes may be made after the same Form and Fashion, as when applied by *Water-Engineers* to perform the like Effects. They shall be made with a wide hollow Foot at Bottom, that they may conveniently stop up or cover the Orifices of *Cases* or *Globes*: The *Compositions* these are filled with must be very *slow*, and mixed with certain Portions of Things which produce Fires of various Colours, and Sparks in abundance. Again, all the Pipes fashioned after the Manner we have here specified, must be also filled with as much of the same *Compositions* as they can contain.

XV.

The utmost Diligence must be applied in conducting the Trains, in fixing and adjusting the *Rockets* and *Crackers*, and in the disposing of all the other Works; in which consists the whole Beauty of the Fabric; and in the Execution of these Articles the *Engineer* will have an Opportunity of displaying his Skill; in short, it is upon his prudent Management of these Circumstances that his Welfare and Life depend; and not only his own, but those also of his Workmen and Spectators: For to say the plain truth of the matter, I have seen many *Fire-works*; but Few, that succeeded so well as might be wished; because the greatest Part of them catching univervally and instantly in a Blaze, have sometimes been the Death of several, and spoiled many unfortunate Persons, who (far from expecting such calamitous Accidents) came to be diverted. Now the industrious *Pyrobolist* will avoid the Danger of these so-much-to-be-dreaded Disasters, if he be particularly cautious to fill all his little Pipes, Fuzes, or Trains of Communication, with a *Composition* whose Sloth he has been assured of, by repeated Experiments. I approve perfectly well of *Quick-Match*, that has been thoroughly dried and duly wrought; and this I advance from my own Experience, having often used it myself with Success: But whether you prefer *Quick Match*, or whether you think that *Slow Composition* will answer your Purpose the best; I say, which soever of them you choose, it shall be laid in Channels or Pipes of Copper: For if they be made of Wood they are presently burnt, or else they split; if they be made or lined with Lead, they melt with the least Heat; if made of Iron they instantly grow Red-hot, and set fire to the wooden Work, Cloth, Paper, &c. and thereby ruin your whole Undertaking; but Copper Tubes or Pipes are exempt from all the abovementioned Accidents, from the natural Hardness, or Solidity of their Metal. These Pipes or Tubes shall be well reinforced with the Sinews of Beasts steeped in
Glue,

Glue, in which has been previously dissolved a little *Allum Plume*. All these Pipes must be laid in Grooves wrought in the Wooden-work of the Machine, or they may be fixed naked from one Fire to another.

The Junctures or Joints of them must be well luted with Clay, or else fastned together with Sinews well steeped in Glue, so that the Fire may have no Excurfion through them. Again; you must make several Vents or breathing Holes through which the Fire may correspond with the ourward Air; for if it be kept close it will either be suffocated, or burst the Pipe which confines it. All these Vents shall be made with such Care and Exactness, that they may not only let out the Fire clear of the other Works, but also (if they are hid in the Planking, or if they are fixed on the Outside) set fire to the *Rockets* and *Crackers*, in consideration that several other Parts of the Machine will be consumed whilst the *Rockets* and *Crackers* are dismissed and discharged: But however as these Vents will not be sufficient to let out the Filth generated from the Smoke and impure Particles of your *Composition* or your *Quick-match*, which will clog up the Train-Pipes (if we may so call them) you may at convenient Distances make Spouts, Gutters, or pretty large Apertures, through which all the *Fæces* may be discharged, and at the same time give Admission to the Air: here also you must take care that the Fiery Filth thus expelled, does not interfere with any of your other Fireworks, but that it may be carried clear off by pretty long Spouts.

Above all Things you must be cautious not to suffer any Match or Fire near your Machine, that you may not be liable to such Disasters as might arise from their Proximity. Upon the whole I apprehend, that I need not trouble myself with giving you particular Instructions for conducting your Trains or Fuzes; and indeed no particular Rule can be laid down to guide you in it; because of the Variety of Postures, Situations, and Contrivances of our Pieces of *Machinery*. It is to be hoped that whosoever attempts any Performances in this Ticklish Art, will by a due attention to the Rules with which we have furnished him in this Work, be able to avoid all Blunders and Mistakes; add to which, that our *Pyrotechnic* Novice may gather sufficient Direction in this Matter from the *Orthographic* and *Scenographic Figures* which we have with so much Care and Industry traced out.

XVI.

The last Thing I would recommend to you is, so to contrive, as to have none but sober, considerate, and virtuous Men concerned in carrying on the Work under you; and never to admit any vile, prophane Men into your Service: For since we must not hope for Success in our most trivial and minute Undertakings without the Concurrence of Heaven; you may readily imagine, That you will stand in the greatest need of the *Celestial Protection*, when encompassed on all Sides with

Fig. N^o 200.

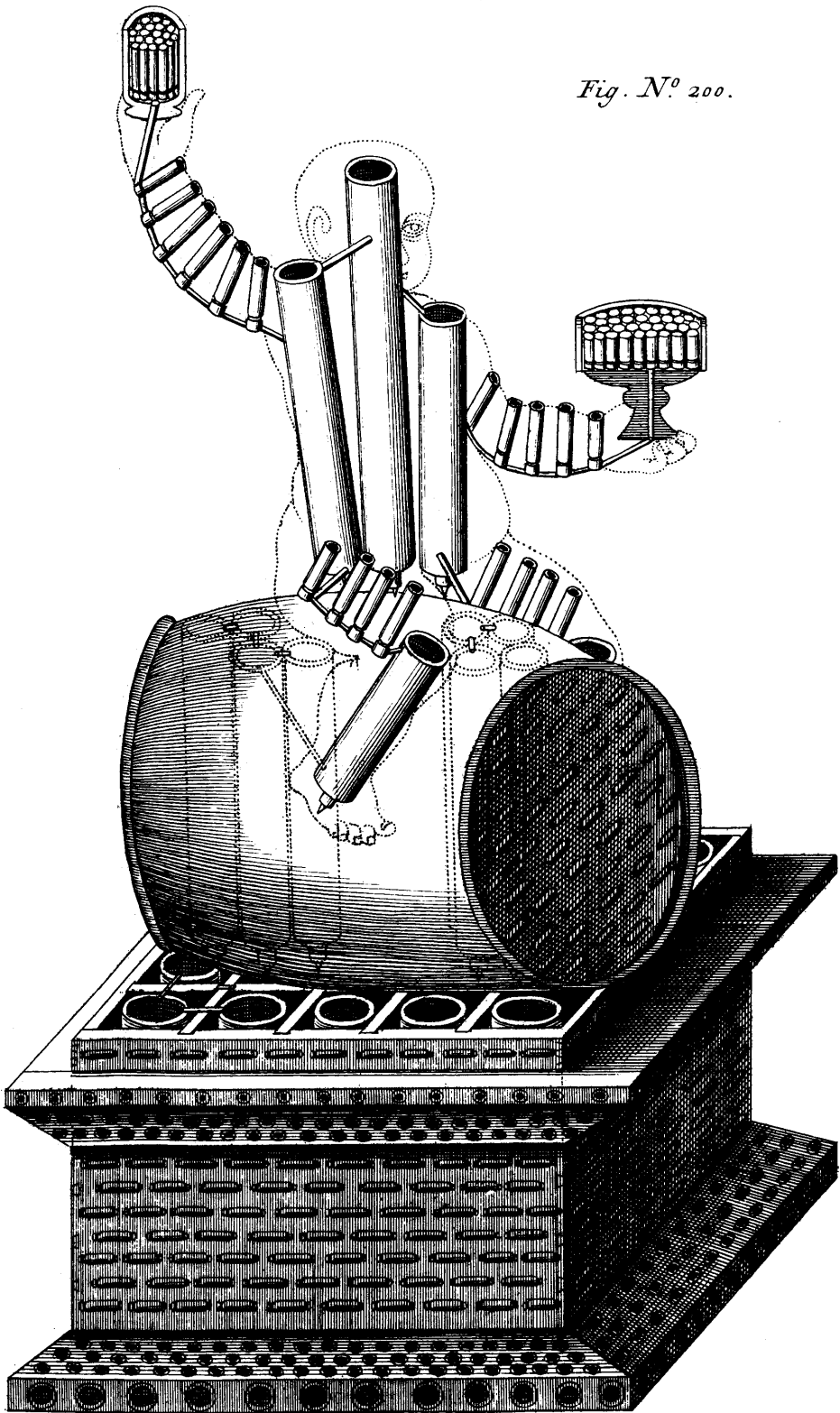

R

P F. Scul.

Fig. N^o 201.



S

P.F. Scul.

Fig. N^o 202.

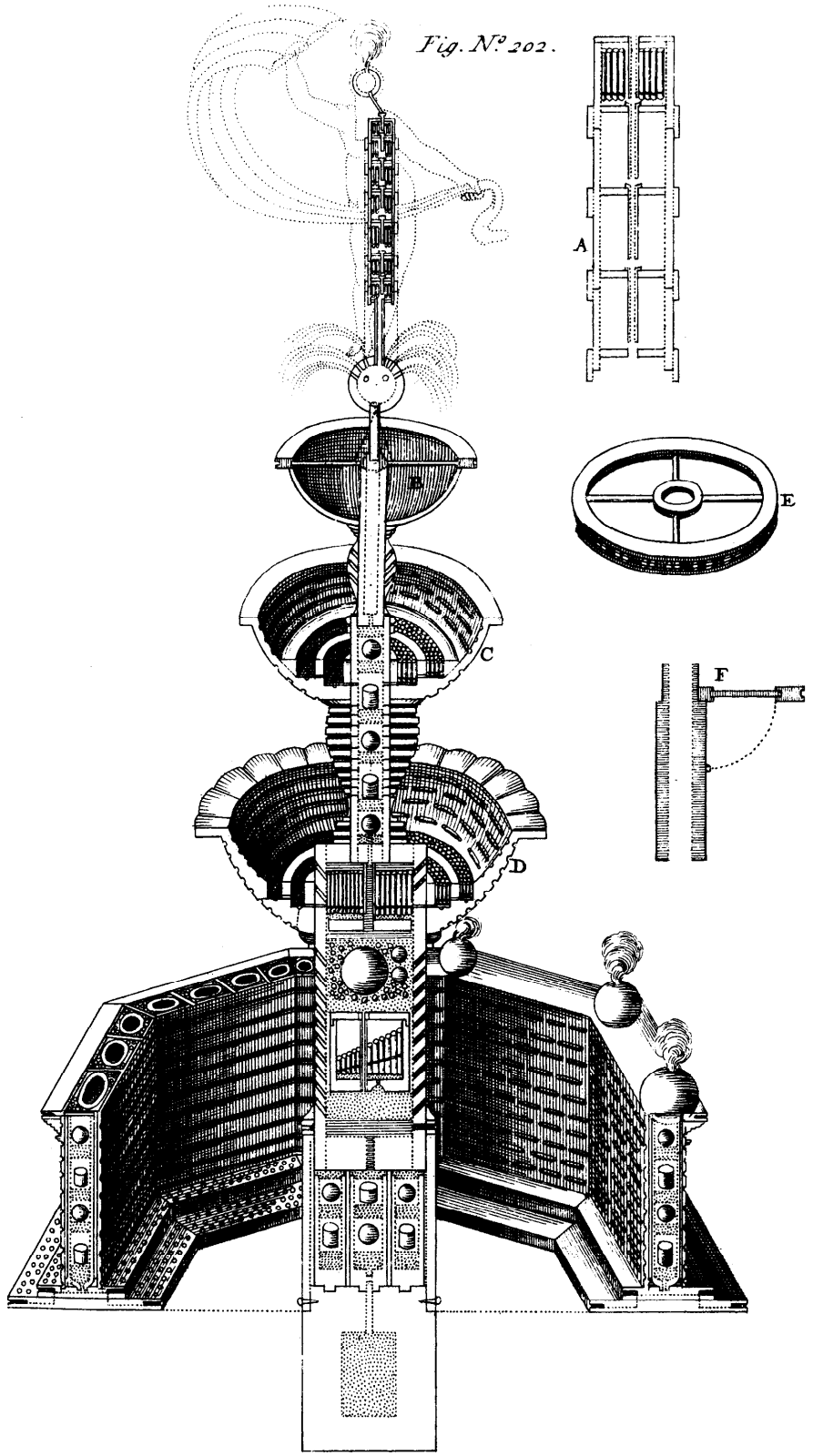
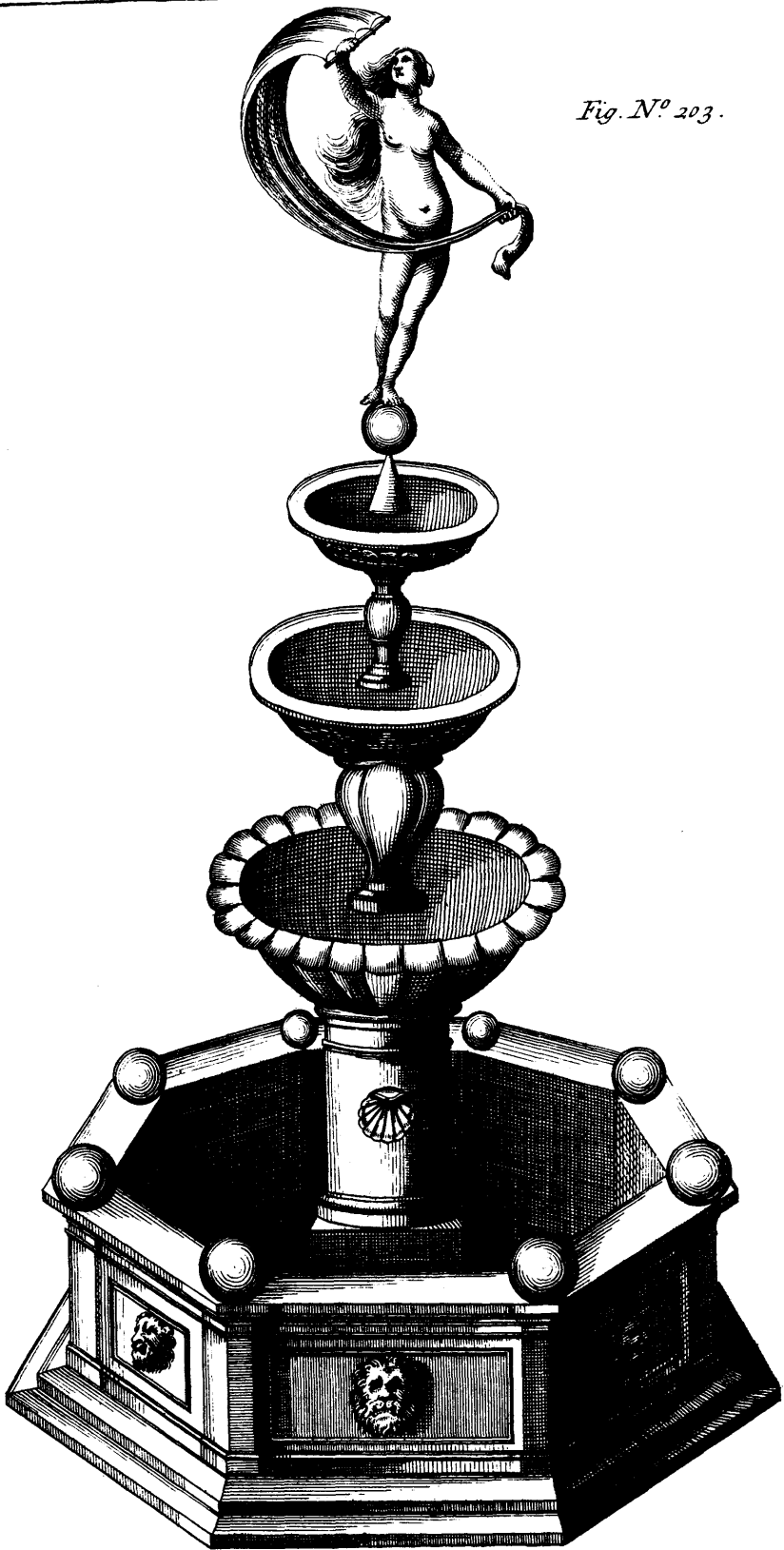

Fig. N° 203.



with extraordinary Dangers, as all those are, who make Profession of our *Art*: And therefore ought you to have a continual Eye upon Heaven, and to depend upon God for your Safeguard and Protection; and endeavour to render yourself a deserving Object of his Mercy and Paternal Care: For the accidental Shock of two Stones, the hasty Attrition of two Strings, nay the very impetuous Rubbing together of two Straws, may be the Death of you, when busied in such perilous Occupations.

What I have farther to say here, is addressed to the Smiths, Carpenters, Brasiers, Joiners, Turners, Masons, Carvers, Plasterers, Painters, and the whole Tribe of Workmen, whose Assistance is required in compleating our *Pyrotechnic Fabrics*. To these I must recommend; as they all act in Subordination to the *Fire-Engineer*, That they endeavour to please him and do him Justice, by observing to execute all his Orders and Directions. In short, the *Engineer* ought to be a perfect Judge of the Capacity of his Workmen, and the Value of their Work when done, and consequently know how to accept the Good, and reject the Bad; for whatever Misfortunes happen, they will all be imputed to him, and not to the Workmen he employed; and on the other Hand, all the Applause resulting from the Successful Construction of the whole Fabric will fall to his Share. Thus must he expect to suffer all the Blame if his Work demerits it, or to bear away all the Praise if it deserves Approbation.

And now having set the last Hand to our *Recreative Fireworks*, after a pretty Long Dissertation on them, (perhaps more so than some could have wished) I shall proceed to the *Second Part of this Book*, in which I shall entertain you with *Artificial Military Fires*.





PART II. of this BOOK.

Which TREATS OF

Serious or Military FIREWORKS,
Whether Fixed, or Projectile.

CHAPTER I.

Of Fire Ollæ or Pots of all Sorts, Powder Flasks, Bottles, Chests, &c.

F all the *Pyrotechnic Defensive Works*, with which I propose to entertain you, in the *Second Part* of this *Fifth Book*; I shall first present you with the several Sorts of *Fire-Pots, Flasks, Bottles, and Chests, &c.* These I shall begin with; because they are more simple in their Construction, than the other Things which are to follow them; and I shall reduce them within the Bounds of this Chapter, because they are in general prepared after one Way, saving some Particulars which are peculiar to each of them apart, which Diversity becomes natural or necessary to them from the Variety of their Figures and Sizes. I shall then instruct you in the several Methods of filling and charging three certain small Vessels.

METHOD I.

In the First Place; Pour *Quick-Lime* finely mealed into some Vessel, till one Third of it be filled; which done, fill it up to the Brim with good *Corn Powder*, and cover it with strong Paper, or a wooden Lid; and over that with a pitched Cloth. You are to tye on Ends of Match to the Neck and Ears or Handles of your *Pot*, if it be made of Clay, Fig. 206. as you may observe in Fig. 206. Your Vessel being thus ordered, and having

having lighted the Match at both Ends, it shall be thrown amongst the Enemy from some Eminence; as for Example, from the Top of a Rampart, or a Wall; or from the *Bastions* of any Fortrefs into the *Fosse* or *Moat*, or to any of the nearest Places if it be delivered by Hand: But it must be projected from proper *Machines*, if you would send it to Distances, such as the Lines or Works of the Enemy. On the other side, these Vessels may be thrown by the Besiegers into the Place besieged; and they may likewise serve in Sea Fights, with great Disadvantage to the Enemy and their Ships; for as soon as these fall upon a Ship's Deck, or meet with any hard Substance, they will never fail to break and fly in Pieces; upon which the *Powder* will be spilt, and scattered abroad, and the Match falling amongst it, it cannot avoid *Accension*; and will accordingly break out with so terrible a Flash, as must spoil and destroy many of the Enemy, and perhaps burn the Ship itself: Not only that; but the *Powder* thus taking Fire it will at the same time blow up the mealed *Quick-Lime*, which rising like a Cloud of Dust, will be insupportable to those who are wrapp'd up in it. Sometimes instead of *Quick-Lime* you may use the Athes of Oak or Elm, provided they are well searced and reduced to an impalpable Meal.

M E T H O D II.

Sometimes they prepare Vessels either of Glass or Earth with long Necks, (the Hollow of which is about an Inch in Diameter,) and bearing a near Resemblance to the *Matrasses*, *Retorts*, and such like Vessels in use with *Chymists*: The Body or Belly of these is filled with *Corn Powder*, to which are added certain Portions of *Mercury Sublimate*, and *Bole-Armoniac*: Sometimes also it is interspersed with Scraps of Iron. The long Neck is to be filled with a *Slow Composition*: which being fired you may throw these Vessels where you please.

M E T H O D III.

If it happens that the Vessel is pretty large, and has a wide Mouth; for example, of 3 or 4 Inches in Breadth, or thereabouts; your *Corn Powder* shall be interspersed with *Crackers*, either single, double, or farther multiplied as you shall think proper: Or instead of them, *Hand Grenado's* without Fuzes, and only filled quite up to the Vent with *Corn Powder*. The Vessels No. 206 shew you both the one and the other of these; whereof the First distinguished by A has *Hand-Grenado's*, the Second by B, has *Iron Crackers*. Fig. 206.

M E T H O D

M E T H O D IV.

There are those who fill these Vessels with very violent *Compositions*, and such as are so obstinately outrageous as not to be suffocated by any Means. We have already given you some *Compositions* of this Nature. Those which we ordered for *Fire Rain* may serve this Purpose very well; but particularly such as we communicated for making the *Grecian Fire*; for that was inclosed in such Vessels as these, as we have elsewhere shewn. However, notwithstanding the several violent Fires I formerly gave you, I shall here present you with some others which are particularly calculated for this Service, and which are in Esteem with the *Pyrotechnicians* of our Days. The First, according to *Fioravantus*: Take of the *Varnish* used in gilding of Leather 10 lb; of *Sulphur Vivum* 6 lb; of *Oil of Rosin* 2 lb; of *Saltpeter* lb ss; of *Olibanum* one lb; of *Camphire* 6 ℥; and of the best *Brandy* 14 ℥: Put them all into a Vessel, and mix them well together over a slow Fire; and being melted, add some Tow to them, and let it steep. This being put into Pots, will produce a Fire that will be inextinguishable, wheresoever it be thrown.

Ufanus in the third Treatise of his *Artillery*, Chap. XX, gives us the following: Take of *Gun-powder*, *Sulphur*, *Saltpeter*, and *Sal Armoniac*, of each lb ss; of *Camphire* 2 ℥; meal them all finely, and pass them through a Searce; which done, add to them a Pinch of common *Salt*. Put all these into a Brass or glazed Earthen Vessel, and pour *Oil of Olives* upon them, or *Oil of Petrol*, or of *Linseed*, or of *Walnuts*; or else melted *Lard*; enough to give the Whole the Consistence of a Paste, or pretty thick Conserve. Being all incorporated well together, take some of it out, and try how it burns, and see whether it can be easily suppressed by the Injection of Water; for if you find it too weak, you must add *Gun-powder* to it. Having brought it to the Pitch you would have it; fill Pots, Pitchers and such like Earthen Vessels with it.

In the same Vessels you may add Lumps of that Liquefied Stuff, which we mentioned in speaking of the Preparation of *Fire-Rain*, wrapping them up in loose *Quick Match*: Or you may use Balls of the Bigness of a large Walnut made of the following *Composition*; taking care to fill up the Interstices between these Balls with a Mixture of *Corn* and *Meal Powder*. This *Composition* is thus: Take *Saltpeter* and *Gun-powder*, of each 2 lb; of *Sulphur* lb ss; of *Colophone* ℥ iiij; of *Camphire* ℥ ij; of *Sal-Armoniac* ℥ j. Incorporate them well together, and knead them with *Oil of Linseed* or *Olives*; and in short, make this *Composition* into Balls of the bigness of a large Walnut. These Balls being once inflamed burn most outrageously; insomuch that if they chance to fall upon a Ship's Deck, they will burn through and through it in the twinkling of an Eye; will set whatever they stick to in a Blaze, and accend and inflame those Substances which are the least susceptible of Fire:

But

Fig. N^o 204.

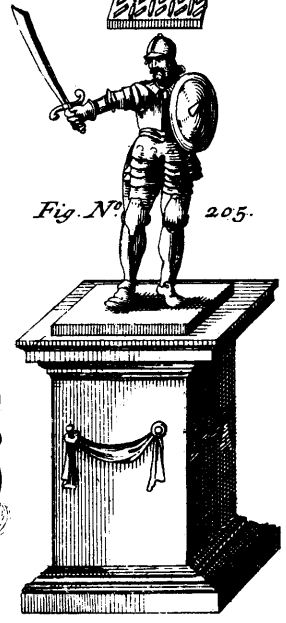
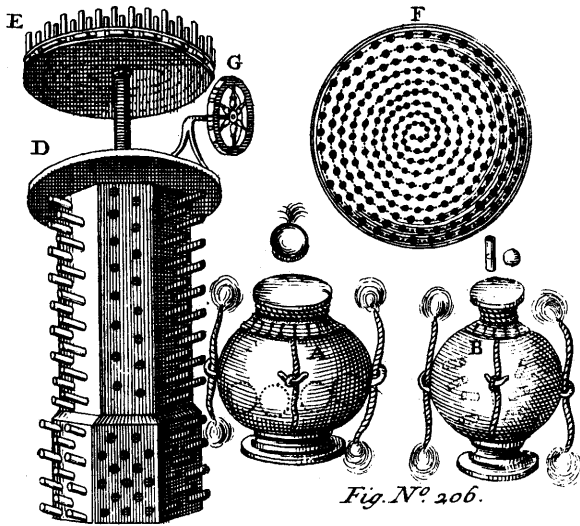
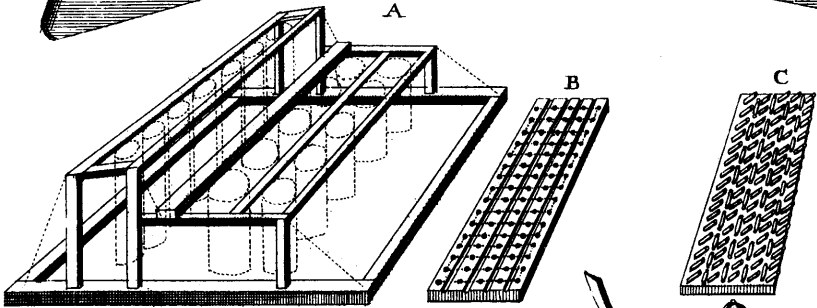
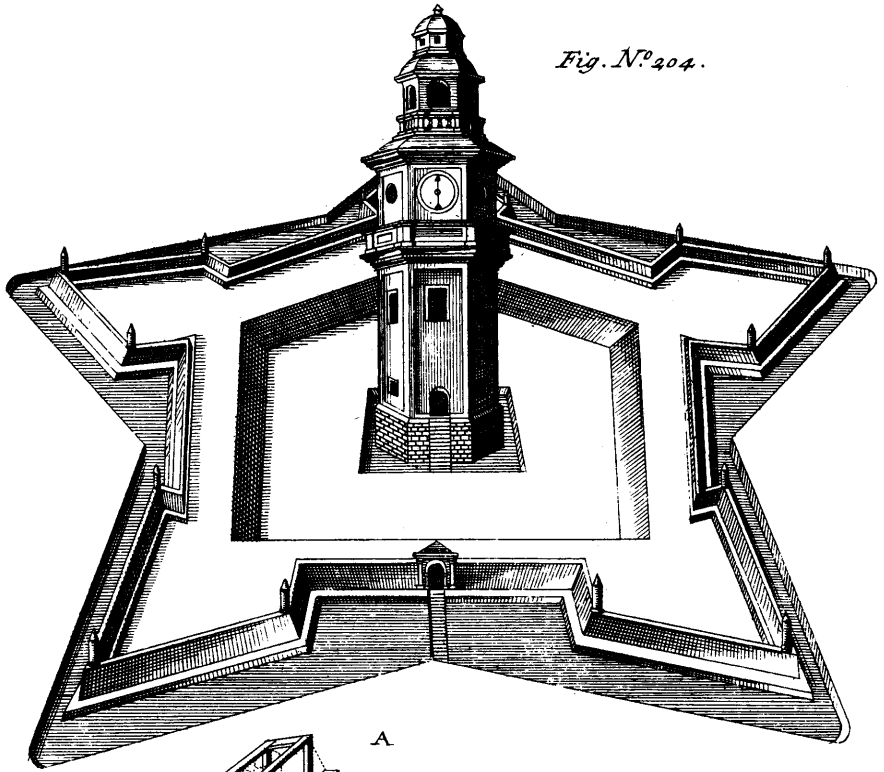

Fig. N^o 205.

Fig. N^o 206.

W

P.F. Sculp.

But what I take to be their most extraordinary Property, is the Impossibility of suffocating or stifling them by any means; and it is particularly in vain to endeavour at a Suppression of their Fire by Water; for far from suffering any Diminution of its Violence by the means of Water; it gathers new Strength, and rages the more obstinately the more it is plied with that Liquid Adversary.

All these Vessels must be stopp'd up or covered close with waxed or pitched Cloths, as we specified above. To the Ears or Handles of them (it is perfectly necessary, that these Vessels should have Handles) you must tye Ends of *Match*, and secure them fast, that they may not drop off. If it happens that your Pots have no Handles, nor any Thing of that Kind, nor even a Neck of sufficient Length to tye your *Match* on by; you must give them a Coating of our *Pyrotechnic Cement*, or of ought else that is of a very tenacious Nature, and stick your *Match* in it all round.

A D V E R T I S E M E N T.

That these *Ollæ* or *Pots* of *Fire*, and several other *Vessels* filled with *Combustible Compositions*, were used by the Ancients, to set Fire to Buildings, &c. is not to be disputed; if we rightly consider the Testimony of so many Authors whom we quoted when we spoke of *Hand-Grenado's* and *Fire-Rain*. But it must be allowed, that all the *Fire-Vessels* of the Ancients were but Trifles and Children's Play-Things, when compared with Ours; or at most, that they were but the Shadows of our Modern *Fire-Pots*; because they wanted our *Thunder-imitating Gun-powder* by the Assistance of which we are enabled to cause such frightful Fla-grations; to burn and destroy the greatest Part of our Adversaries; and particularly, if to these *Pots* you add *Hand-Grenado's* or *Crackers*.

C H A P. II.

Of Fire-Crowns and Garlands, which the Germans call Pech, and Sturm Krantzen.

HE that would render himself Worthy of a Mural or Naval Crown, and who is ambitious of being honoured with one from the Hands of his King or Prince; I say, whosoever is desirous of being distinguished by those proud Marks and Badges, which are bestowed on Merit and Virtue, must, the better to qualify himself, know how to manage our *Pyrotechnic Crowns*; he must prove them and put them in Execution, if he expects to see his Temples adorned with a Wreath of Laurel.

F f f f

Our

Our *Diadems* and *Garlands*, I must own, will burn, and oftentimes prick those who handle them; but who knows not that Roses are gathered amongst Thorns? And that all our most perfect Happiness, and most tranquil Contentment in this World, take Birth, in the midst of the most pungent Sorrows, and a thousand afflicting Difficulties, which perpetually oppose us in our Pursuits of what we would enjoy. No one ever yet obtained Glory, but by struggling, and combating with Misfortunes and Labour: It is no small *Enticium* upon a Soldier to say of him, *That he is both able and willing to endure Hardships*. This Acknowledgment is the natural Right of a true Soldier, and what he may lay just Claim to, whatever else he may stand in need of. Thus though the Man who is crowned with our *Fire-Garlands* will be grievously laden, yet at the same time he will be pompously adorned; if his Actions are levelled at nothing but pure Glory; if he contemns Difficulties, and bears with Heroic Constancy all those Hardships which oppose his Acquisition of the Prize he thirsts after. Now in this Chapter I mean to inform you of what Flowers and Ornaments our *Crowns* and *Garlands* are composed.

Get a long Bag made either of Flaxen or Hempen Cloth, of the Breadth of 4 or 6 Inches, and of the Length of 3 or 4 Foot; and fill it with one of the *Compositions* we gave for *Fire-Balls*. The following *Compositions* are purely for these *Garlands*, &c.

I.

Take of *Salt-peter* 3 lb; of *Sulphur* one lb; of *Powder* 2 lb; and of *Powder of Glass* lb ss.

II.

Take of *Salt-peter* 3 lb; of *Sulphur* one lb; of *Charcoal* lb ss; of *Powder of Glass* 3 iij.

III.

Take of *Powder* 2 lb; of *Salt-peter* 3 lb; of *Colophone* lb ss; meal them finely, and mix them well: Having filled your Bag with one of these *Compositions*, bend it round into a Circle; so that the two Ends may meet, which must be sewed together: And for fear the Stitches should give way, or be burned during the Combustion of your *Garland*, you shall clap an Iron Hoop within it, whose exterior Circumference is equal to the interior Circuit of the Bag. Upon this Hoop then must your rounded Bag be securely laced, and fastened with Interweavings and Knots at proper Distances from each other, in Imitation of what we ordered of the same Kind for *Fire-Balls*. Being thus adjusted, you must thrust *Iron Crackers* into it; which *Crackers* shall be well charged with *Powder* and *Ball*; and pointed at Bottom, that they may the more easily penetrate the *Composition*: Or you may dispose of them, as may

Fig. 207, be remarked in Fig. 207 and 208.

and 208. The third Sort of our *Crowns* you have in Fig. 209: This is only
Fig. 209. armed with bearded Iron Spikes; with intent that if it should chance

to fall upon the Head of any Person, he may not be able to take hold on it, to throw it from him; but be obliged to burn alive, and from this sort of Torment, which may be said to be its natural Effect, it may justly enough be called the *Martyrizing Crown*.

Sometimes also these *Crowns* are adorned, or rather armed, with *Hand Grenado's*, of the bigness of an Iron Bullet of one or 2 Pounds Weight; but they must have Fuzes of the Length of 3 or 4 Fingers screwed into their Orifices to keep them tight and firm upon the said *Crowns* or *Garlands*, and for the same Purpose also must they be laced on with Iron Wire. You have the Representation of this in Fig. 210.

Fig. 210.

These *Crowns* and *Garlands* are applied to the very same Uses as the *Fire-Pots* and other *Vessels* which we described to you in the foregoing *Chapter*: I shall only add to what I have said, That you must take Care to make two or three Holes, through which to fire the included *Composition*; and being lighted and inflamed on all Sides, you may throw them where-ever you shall think proper.

C H A P. III.

Of Fire-Hoops or Artificial Spheres.

IF you have a right Idea of the manner of preparing the *Fire-Crowns* we just now spoke of; you will meet with no Difficulty in ordering *Artificial Spheres*, which are only composed of several Hoops or Rings within one another, and placed Cross-wise. Prepare then three or four Hoops or *Crowns* (according to the Directions we gave you in the foregoing *Chapter*.) of such Size and Proportion to each other, that they may go into, or be received into one another, from the greatest of them to the least; (that is) That the Interior Circumference of the First, be exactly the Exterior Circumference of the Second, and the Interior Circumference of the Second, be exactly the Exterior Circumference of the Third, and so on. Being thus ordered, put them together, (*viz.*) the two First, at Right-Angles to each other; and the two Smaller, at Right-Angles between themselves, but at an Angle of 45 Degrees with respect to the two Greater; or if you have more than four Hoops, they shall be all so ordered as mutually to intersect each other at Acute Angles in the two Points which are Diametrically opposite. To these you may add others which may embrace them round, or be in a right Direction to the First; but they shall be bound on with Copper or Iron Wire; for if you only fasten them with Marline, it will be presently burnt; by which means your Work will fall to pieces, and yourself be baulked in your Expectations.

But

But by the way I must tell you, that it will be proper to have large Hoops for these *Spheres*; I mean, that they must be of several Foot in Circumference. The largest of them (for Example) shall be 15 Foot in its outward Circumference, and the rest proportioned to it, as we said above. It is also necessary to dip them all in Tar, and to pierce them with several Holes or Vents; that the whole Body of them may be fired at once, or in several Places, and consequently, that it may be impossible for the Enemy to suffocate them, or disengage themselves from the frightful Disorders these *Spheres* will introduce amongst them. I have not given you any *Figure* of these; because the Construction of them may be easily gathered from what we have been saying, and by the Figures of our *Artificial Crowns*. As for that whose Representation you

Fig. 211. have in Fig. 211, it differs from those we have above-described: *Hanzelet* will have it constructed thus.

Take a Wooden Hoop, or (what will be better) an Iron one, just such as Coopers use for binding their Cask: Daub it over with *Tar* mixed with *Gun-powder*, and take a Band or Slip of Cloth, whose Length must be equal the Circumference of the Hoop, and of the Breadth of three Inches: Wrap this Band round the Hoop, and fill it with a *Composition* made of one lb of *Powder*, one $\frac{3}{4}$ of *Sulphur*, and 3 lb of *Saltpeter*, sprinkled over with a little *Oil of Petrol* or *Linseed*, and interspersed with Scraps of *Sulphur*. This done; sew up your Cloth, and re-inforce it throughout with a Wounding of Marline, and pierce it in several Places with an Iron Point, filling all the Holes you pierce, with *Quick Match*. In short, the whole exterior Surface of the Hoop shall be garnished with *Sulphur*, which must be wrapped round with *Tow*, excepting the Vents or Primings of *Quick Match* which must be left free and open. This is but half your Work; for you must prepare another Hoop after the very same manner (or several if you please) and having fix'd them in one another, you shall fasten them together with *Wire*, to prevent them from falling asunder when thrown from any Eminence amongst the Enemy. Being thus prepared and adjusted, you must fire the *Quick Match* before-mentioned, and upon finding that your *Composition* is thoroughly accended, you may throw this *Sphere* where you please.



C H A P. IV.

Of ARTIFICIAL CYLINDERS.

I Must here say once more what I have very often advanced already, namely, That we owe our Ingenuity in *Pyrotechnics* to Hints taken from former Inventions. I know that we improve a great many Things in our *Art*, which we pretend were unknown to the Ancients; many of which I am far from thinking they were wholly ignorant of; and it is not impossible, that former Ages might have had a more distinct and perfect Knowledge of some Things which we attribute to our Invention, than we have ourselves, (saving what relates to *Gun-powder*) but which by a long Succession of Time have been insensibly annihilated, and were never handed down to us. Now the Men of our Age are of such a Turn, That having never so superficially considered any of the Pieces of Antiquity, they dive presently to the Bottom of them, and unravel them at once; and thereupon their Hearts being distended with Vanity, they fancy themselves to be the very Inventors of Them. Whence it is, that they give them out, not only as their own, boast of them, and praise them up; but also arrogantly despise the Worthy and Ingenious of the Times past, who were in all probability at as much Trouble in the Cultivation of those Things as we have been. For my part, I acknowledge that the earlier Ages of the World were productive of very great Men, and such as were inspired with an Inventive Spirit; but it must be at the same time allowed, that we may justly claim some share of Applause and Approbation in Conjunction with them; inasmuch as we have been able to make great Additions to their ingenious Practice; and inasmuch as we know how to choose what is profitable to us from amongst their Inventions, and separate it from what is unuseful to us, and after having cleaned it, and scowered off the Rust it had contracted by a Length of Years, have been at the Pains to restore it to its Original Lustre. But I shall always stand firm in the Opinion which I have so often communicated in this *Work*, notwithstanding any Arguments I can foresee to convince of the contrary, (namely) that the Works of the Ancients were lame and imperfect through their Want of our *Gun-powder*; and that they conceived only the Shadows, and not the perfect and true Idea's of the admirable *Machines of War*. I formerly gave you some of their *Engines*, and after having compared them with ours, I made it evident to you, how much our Modern *Machines* surpass them in Dignity and Contrivance. I shall here again present you with several others: But before I do that, I shall make it appear by the Testimony of an-

G g g g g

cient

cient Authors, that the *Pyrotechnic Cylinder* is a very antique Invention; which done, I shall shew you what Improvements the Moderns have tacked to it.

Let us first consult *Vegetius* upon this Subject, and give Ear to what he says of these *Cylinders*. He speaks thus of them in *Lib. IV. Cap. viii.* where he teaches us to construct several *Machines* for the Defence of Walls. *They made prodigious Wheels of Green Wood, or Cylinders of the Bodies of vast Trees; (which they called Rollers) these they rounded very exactly that they might be the more rollable, and being trundled down Declivities, they ran over the Enemy and frighten'd their Horses.* Let us now hear what *Ammianus Marcellinus* has to say of this Matter: *The greatest part of those who were concerned in the Assault, or made any Attempts to scale the Walls, were overwhelmed and buried under great Stones, vast pieces of Columns, and by Cylinders which were rolled down the Declivities and Taluds of the Walls.*

It appears then by these two Authors (not to quote any Thing from others) that the Ancients converted or applied the *Cylinder* to Warlike Uses. But these could hurt none but the most Bold and Daring of the Besiegers, who attempted to scale the Walls of the Besieged; and only lamed them, broke their Ladders, and crushed the *Machines* or Persons they happened to fall upon; leaving the Soldiers and Works, which were but a little distant from them, out of Danger. But our *Cylinders* are much more *Artificial*, and vastly more efficacious; for they not only by their Weight break and destroy whatever they fall upon, but also kill such Persons as are far distant from them, and throw down and demolish their *Machines* tho' pretty remote: For being hollowed, and then charged with Stones, Pebbles, Iron Bolts, and such like; together with a good Quantity of *Gun-powder*; they are capable of doing incredible Mischiefs. But before they are put in Execution they must be bound or reinforced with strong Iron Rings, one at each Extremity of the *Cylinder*, and one at each End of the Charge of *Powder*. This is the

Fig. 212. first Sort of our *Cylinders*, which I have represented in *Fig. 212.* where the Letter A distinguishes a Wooden Stopple or Tompion for heading up the Orifices of it.

Fig. 213. You have the second Sort in *Fig. 213.* It is armed all over with bearded Spikes; that it may not only be capable of Destruction by its Weight, by its Mortal Bowels, by its Flame and Fire; (all which it has in common with the First) but also tear and wound those with its Spikes, who are hardy enough to be Foremost in an Attack, or in mounting a Breach. This also must be reinforced at each End with a Substantial Iron Ring.

Fig. 214. The third Sort of *Cylinder*, which you have in *Fig. 214.* is yet more Artificial, and more cruelly adapted for Execution, than either of the Former; for the whole Capacity of it is filled with *Hand Grenado's* and *Crackers*, of several Sorts (ordered as usual) the Interstices of which
are

are filled up with *Gun-powder*. Now this *Cylinder* is commonly composed of two *Semi-Cylinders*, as may be conceived by the Profil A. The two Pieces of this *Cylinder* must be forelocked or wedged together, and that so closely, that no Air may have Admission into the Body of it, whereby it will be consequently obliged to burst with the Greater Violence. This *Cylinder* must have a small Wooden Fuze to correspond with the *Powder*, which Fuze must be filled with one of the *Compositions* we formerly gave you for the Fuzes of all Sorts of *Grenado's*.

To conclude, I here give you a fourth *Cylinder*; of which the Ancients had some Knowledge, if we may believe *Sallust*; for I find that he writes to this Effect in his *Remains*. *They rolled down the Declivities vast Pieces of Rocks and Beams mounted upon Axles, and armed with Spikes, or short Darts, like the Military Ericii, or Chevaux de Frise*. But, good God! to what a horrid Point of destructive Power have we brought this *Cylinder*, by means of our *Gun-powder*? For that spoken of by *Sallust*, was no more to ours, than a Shadow is to a Substance. You have the Representation of this in *Fig. 215*, and by the Construc-
Fig. 215.
tion of it, I shall evince that I have not exceeded the Bounds of Truth in the Assertion I have here advanced, and shall shew you how far we have improved upon the antique *Cylinder* of this Kind: The following Description of it is taken from *Hanzelet*. “Get a *Cylinder* hollowed
“or bored throughout the Middle to the Breadth of 2 or 3 Inches, like
“our Recreative Cases. The whole exterior Surface of it (excepting
“its Bases or Ends) shall be stuck or armed with long Iron Spikes, be-
“tween which you must fix *Grenado's* of a moderate Size: The Fuzes
“of these *Grenado's* must be of Iron, and not only screwed into the
“Vents of the *Grenado's*, but also into the *Cylinder*, (see *Fig. A*) by
“which means they will be immoveably fixed: Again; these Fuzes
“must be of such Length, as to reach close home to the *Composition*
“contained in the Body of the *Cylinder*. The whole being thus or-
“dered, shall be mounted upon two common Wheels, such as those of
“a Chariot with their Axle-Trees, which must exactly fit the Orifi-
“ces of the *Cylinder*, and be securely stuck into them: These Axles
“shall be also bored throughout to the Breadth of an Inch or there-
“abouts, which Borings must be filled with the usual *Compositions* for
“Fuzes. In fine, this furious Body (which for its admirable Construc-
“tion and wonderful Effects might justly be stiled a *Machine*) shall be
“pitched all over, and being mounted upon the Axles, and fired at
“each End, may be rolled down amongst the Enemy; there to per-
“form such Havoc, as could not be effected by a Thousand of the
“antique Sort.” To tell you now, how that is possible, would be en-
tirely superfluous and needless, since any Person who has but the least
glimmering Insight into our *Art*, will readily conceive it. And
therefore not thinking it worth while, to dwell upon a Matter which
is

is so self-evident, I shall proceed to the short Remainder of this *Treatise*.

C H A P. V.

Of F I R E-S A C K S.

THESE *Artificial Sacks* are applied to the same Uses in the Defence of Places, when attacked, or attempted to be stormed or scaladed, as the *Cylinders* above-mentioned. They are ordered thus: Take a pretty thick Wooden Bar of several Feet in Length, and square it, or convert it into a Parallelopiped, and let the two Ends of it be cut sharp, or in the Form of a Pyramid. Towards the Ends of it, you shall bore two Holes, nearly intersecting each other at Right Angles; into which you must thrust two Wooden Tree-Nails, shod or armed at each End

Fig. 216. with Iron, as may be seen in *Fig. 216*, by the Letter A. Upon this Bar you must tye a strong Canvas Sack, which must be pretty wide; that it may contain a good Quantity of one of the *Compositions* we ordered for *Fire-Balls*. Having tied it fast to the Bar by one of its Ends, fill it at the other with a proper *Composition*, and ram it and shake it down 'till it be as hard as what we directed when we spoke of the *Filling of Fire-Balls*. In short, tar the whole Body of it over, and coat it with

Fig. 217. *Tow*. You have this in *Fig. 217*.

Fig. 218. The other *Sack*, which you see in *Fig. 218*, differs from the foregoing, in that its Bulk is uniform and equal from one End to the other; without swelling or bellying out, more in the Middle than at the Extremities; as may be perceived by the *Figure*: Add to which, that it has no Bar or Axle running through the Body of it, like the foregoing; but has only two small Wooden Fuzes, fixed in each Mouth of the *Sack*, which are filled with a *slow Composition*. What we have here said of the foregoing, together with the *Figures* we have referred to, will give you a perfect Idea of whatever relates to this. These *Sacks* must be armed on the Outside with *Iron Crackers*.



C H A P. VI.

Of ARTIFICIAL TUNS and BARRELS.

THAT *Tuns* and *Barrels*, as well as *Cylinders*, were used by the ancient *Greeks* and *Romans*, and several other Nations that flourished with them, in the Defence of Places besieged, may be gathered from what we are now going to communicate. First then, † *Dio Cassius* speaking of *Tiberius*, who had besieged a Place situated upon a Rock in *Denmark*, speaks to this Effect. *The ‡ Dalmatae galled them with Stones thrown from Slings, or rolled down by Hand; they likewise trundled down Wheels, and Cars full of Stones, together with Chests and Tuns, or Barrels made round after the Fashion of the Country, all full of Pebbles. Hiero* also relates something of this Nature, *They contrived to roll down Columns, Wheels, Chariots or Cars heavily laden, Vessels full of Pebbles or wet Earth, like those composed of Staves in which Oil, Wine, and such like Liquors are kept. Ammianus* writes much to the same Purpose, || *Having boldly passed the Fosse or Ditch over Hurdles, and gained the Foot of the Wall; they were immediately overwhelmed with vast Pieces of Stone, and Fragments of Columns, together with Tuns.* Now we can gather nothing from the Testimony of these Authors, and they prove nothing farther; than, that by such like Contrivances, they crushed the Enemy to Pieces, and tore down their *Machines*. The Art of doing this is not so difficult, nor the Practice of it so obscure; but that we might easily act it over again, if we thought it in any wise proper or necessary for the Defence of Places: But our *Gun-powder* has suggested far other Ways of defending ourselves against those, who would make any hurtful Attempt upon our Lives and Fortunes. We now prepare great Tuns, in the Center of which we fix a lesser Vessel or Cask full of *Powder*, or else a large Bomb; which we surround with Stones, Pebbles, Iron Bolts, &c. the Interstices between which we fill with *Quick Lime*. The Vessel being crammed after this Manner with as much as it can hold, is headed up, and well bound with Iron Hoops. In short, having fix'd a Fuze in it to correspond with the *Powder*, it is thrown down from the Ramparts amongst the Enemy, where it does more Mischiefe in an Instant, than all the *Machines* of the Ancients could do in ten Days.

Now the Havoc made by these Contrivances is so prodigious and frightful, that it is impossible for me to inculcate an Idea of it into you, and much less can I make you believe it, except you have ever hap-

† Dio. Cass. Lib. LVI.

‡ Now called *Slavonians*.

|| Amm. Lib. XX.

pened to be in some sort an Eye-Witness of it upon Warlike Occasions. I for my part believe it is impossible for Human Wit to invent any Thing more efficacious than these, to cut off the Enemy when resolved to carry you by Storm, to assuage the Violence of Attacks, and to cast a Damp upon the most Resolute and Courageous. We have a dismal Example of the horrible Effects of these *Murthering Machines* in the Siege of *St. Andrews* in *Scotland*, which was invested in the Year of our Redemption 1524; at which Time one of these *Tuns*, filled with *Powder*, *Stones*, and *Iron Bolts*, being rolled down amongst the Enemy, it wounded 600 of them at once, of which Number 321 remained Dead upon the Spot. We are informed of this by *Hierom Ruffel*, an *Italian*, in his *Precepts of the Modern Arts of War*.

The Besiegers might on the other hand throw such *Vessels* as these into the Places besieged, (as also *Cylinders* and *Sacks*) if they had *Machines* proper for that Service, and particularly, if it was thought worth while to revive the *Balista* of Antiquity; which we shall not here enlarge upon, having spoken of it sufficiently already.

Sometimes also these *Artificial Barrels* might be buried under Ground in any narrow Passage, or at the Entrance of any Place, or before the Gate of a Town; artfully fixing in them a Gun-lock with a good Flint, and having a long Line or Thread made fast to the Trigger, to fire your *Gun-powder* or (if we may so express ourselves) spring your *Mine*, whenever you think proper; but the abovementioned Line must run under Ground, that it may not appear. If this Contrivance does not please you, you may (to be surer) put a Piece of lighted common *Match* into them, or some of our *Quick Match* twisted, and ordered so as to burn till the Time you expect the Enemy to come upon that Place, in order to carry on their Attack: But you must so contrive, that the *Match* may breath the Air by a little Tunnel or Pipe, which must reach quite up to the Surface of the Ground; for fear the Coal of the *Match* should be stifled by its own Ashes, and consequently baulk your Expectation. But I need not trouble myself with giving you any farther Advice upon this Subject: The skilful *Engineer* cannot be at a Loss in managing this Matter with Success.

We find that Necessity formerly suggested several Methods to the Besieged, of not only breaking down and overthrowing the *Machines* of the Assailants by the Weight of Stones, and other Ponderous Bodies, which they threw at them; but also of burning, and reducing them to Ashes. And therefore amongst other Inventions, they filled *Barrels* and *Tuns* with Combustible Things, and sent them amongst the Enemy's Works: Witness *Cæsar* in *Lib. II. of the Civil Wars*; who speaking of the Siege of *Marseilles*, says, "That finding the Besieged very obstinate in defending themselves, a *Musculus* or Gallery was ordered to be built of 60 Foot in Length, which had a sloping Roof, covered with Tiles and Dirt to preserve it from the Fires which might be thrown from the
" Walls;

“ Walls; which Tiles and Dirt were covered with Hides to prevent
 “ them from being torn away by Water which might be plaid upon
 “ them; and the Hides were again covered with Cloths steeped
 “ in Vinegar; in short, the Body of this Gallery being made of vast
 “ Timber securely bound and clamp'd together with Iron, and the
 “ whole of it compleated and fortified, it was moved upon Rollers close
 “ home to the Walls of the Besieged. The Garrison being astonished
 “ at this unexpected *Machine*, tore up the largest Stones that could be
 “ raised with Crows, and threw them from their Walls upon the Gal-
 “ lery; but it was so substantially built, that it received no Damage
 “ from the Shocks of them, and what fell upon the Roof of it presently
 “ rolled off. He then says, That the Besieged finding it was to no Pur-
 “ pose to make any farther Efforts to destroy the Gallery by Dint of
 “ Weight, they bethought themselves of another Stratagem; which
 “ was, to fill Butts, Tuns, and such like Vessels with Pitch, and the
 “ Heart of the Pine Tree, which they threw down all in a Flame up-
 “ on the Gallery, but they immediately rolled off, and were easily re-
 “ moved out of the way of doing Harm, by long Prongs or Pitch-forks.
 “ In the mean time the Soldiers that were under the Covert of the Gal-
 “ lery, loosened and pulled out the lowermost Stones of the Enemy's
 “ Tower; and having taken out a good Parcel of them, and under-
 “ mined it, a Part of it fell down with a sudden Ruin.”

The Thought of the Besieged, in this Case, pleases me much; but I
 can by no means approve of the Effect of their *Artificial Tuns* and *Bar-
 rels*: They would have seen far other Execution performed by those
Vessels, if they (unfortunate People!) had had any Knowledge of our
Gun-powder; and from thence have hit upon a Preparation of their *Tuns*
 after our Modern Way. There is no Gallery how impenetrable soever it
 may appear, nor no Covert so strong; no Hides, Planks, Blinds, nor
 Chandeleers so thick; no armed Men, tho' cased in Steel to the very
 Teeth, that could bear the Shock of large Pebbles, Iron Bolts, or of
 the Shells which we usually inclose in these cruel *Machines*. Happy the
 Man who can avoid the Fury of them, or provide for his Safety by
 Flight, before the *Powder* in them catches Fire! Instead of amusing him-
 self with removing or thrusting our *Tuns* and *Barrels* away from the
 Works with Prongs.

I have given you the Representations of our *Artificial Barrels* in *Fig. Fig. 219,*
 219, 220 and 221. But the last of them shews you two *Barrels* mount-^{220, 221.}
 ed upon one and the same Iron Axle: These are not filled with Stones,
 but with *Grenado's*, *Crackers*, and *Corn Powder*, and are well bound
 with Iron Hoops, and struck round with Steel Spikes. The Reason of
 their being armed after this Manner, is to defend them from the At-
 tempts of certain Fool-hardy Persons; who might venture to cut them
 in pieces with Axes, before the Fire can have penetrated to the *Powder*
 contained in the *Barrels*; for the same Reason it is, that they are mount-
 ed

ed upon Iron Axles, and that the Wheels have Iron Straiks and Spokes of the same Metal.

If these *Artificial Barrels* are not very large and heavy, they might serve in Sea-Fights, and be thrown into the Enemy's Ships, as well as *Fire-Pots*.

You must take great Care in fixing the Fuzes, for that is the main Point; and without being particularly cautious in ordering this Article, you run the Hazard of seeing your Work prove abortive.

In the two first of these *Figures*, the Letter A shews you a small *Barrel*, and a *Grenado* or *Bomb* which are fixed in the Center of their respective *Barrels*. The rest will be easily conceived by the *Figures*.

C H A P VII.

Of Pyrotechnic Flambeaus or Torches.

B*Y Torches* we understand nothing more than certain *Brands* of *Artificial Fire*, which are thrown at Distances to fire the Enemy's Works: But to say the Truth, they are not much in Request with us, and in short, are grown quite out of Use. The Ancients practised them formerly with very good Success, as we are told by *Vitruvius*. *The Divine Cæsar having his Army about the Alps, commanded the adjacent Towns to submit themselves, and yield him free Passage, &c. but there was a Castle near, which depending upon its natural Strength refused Obedience to the Summons: Upon which the Emperor commanded his Troops to advance towards it. This Castle was called Larignum, and before the Gate of it there was a Tower built of the beforementioned Wood, and composed of great Beams lying athwart each other (alternately) like a Funeral Pile, which being pretty high, they might from thence repel the Assaultants with † Spears and Stones. Cæsar being informed that they had no other Weapons of Defence but Spears, which were too heavy to be thrown far from the Walls; he ordered little Fascines or Fagots to be made, and thrown at the said Tower, together with Brands or Torches, in order to set it on Fire. This was accordingly done, and whilst the Heaps of Fascines were in a Blaze, it seemed to every Body as if the Tower was really burned down to the Ground. But the Fire going out, and the Tower appearing whole and untouched, Cæsar was astonished at it, and ordered his Army to advance up to it, and insult it; upon which the Besieged being struck with Dread, they surrendered; and being asked what Wood it was that had thus been able to withstand the Rage of Fire; they pointed at some of the Trees, which are in great Plenty in these Parts. This Wood is called Larigna, from whence the Castle itself is called Larignum.*

† The Latin Word is *Sudes*, which were properly a kind of *Staves*.

Silius mentions these *Torches* in *Pugn. Canen.*

*Ullum nec desit teli genus, hi Sude pignant,
Hi Pinu flagrante cient; hi pondere Pili.*

In *English* :

They deal all missive Arms, fatal to Life;
These with the flaming *Torch* provoke the Strife,
Those with the Javelin's Weight, &c. —

Lucan also in his *Pharsalia.*

———— *inde Sagittæ
Inde Faces, & Saxa volant.*

In *English* :

Thence *Stones*, thence *Brands* and *Arrows* fly.

Virgil also saith somewhere.

Jamque faces & saxa volant, furor arma ministrat.

In *English* :

And *Brands* and *Stones* in rattling Vollies fly;
And all the Rustic Arms that Fury can supply. *Dryden.*

Lipsius also in *Lib. V.* of his *Poliiorcetican*, tells us how the Ancients were used to prepare these *Torches*, in these Terms: *The common Torches were those which were made of Pine, Larch, and Fir: The smaller Sort of these they had for private Use in their Houses; but with the larger Sort they fought, and threw them by hand at the Enemy's Works to set them on Fire.*

All this is Old: But our celebrated Annalist *Paulus Piasecius* will furnish us with an Example of a fresher Date; for speaking of the Siege of *Wielkoluki* (a Town in *Muscovy*) when it was invested and taken by *Stephen King of Poland*, he tells us; “ That the aforesaid Town being
“ surrounded by an Enceint composed of vast Bodies of Timber, upon
“ which Account, and for other Reasons, it was found to be Proof a-
“ gainst all Battery; and the King perceiving there was no Likelihood
“ of reducing the Place by any other Means than a Conflagration; he
“ had recourse to Mines, which being sprung, blew up a Rampart, and
“ set fire to the neighbouring Parts, which was extinguished by the Di-
“ ligence of the *Moscovites* besieged; but that same Evening they con-
“ veyed *Brands* or *Torches* made of *Sulphur*, to the other Side of the
“ Town, which lying latent for several Hours, it was thought they
“ were extinguished by the Dampness of the Ground: But a high Wind
“ arising towards Midnight, they flamed out a-fresh, and in a very lit-
“ tle time the Conflagration became general, and the whole Place was
“ laid in Ashes; and above two Thirds of the Inhabitants were destroyed.

This is what I had to say of the Use and Effects of *Artificial Torches* and *Fire-brands*. I have nothing now to do, but to instruct you in the Preparation of them by the Rules of our *Art*; in case the Exigence of Affairs should make it necessary for you to put them in Practice. Take then of *Sulphur* 8 Parts; of *Colophone* 2 Parts; of *Saltpeter* 4 Parts; of *Black Pitch* 1 Part; of *Wax* half a Part, and of *Turpentine* 1 Part. Having mixed these Ingredients well together in a glazed Earthen Pot, or in any Brass Vessel, melt them over a Fire; and being fused, throw into them some Old Linnen well washed and dried, or else Tow; but which soever of these you make choice of, you shall let it steep in the above-said *Liquified Composition*; and taking it out whilst it is warm, you must wrap it about long Sticks and bind it upon them with Iron or Lattin Wyre; but before you do this, you must drive Nails into your Sticks, that the Stuff may have the faster Hold upon them. Your *Torches* being thus prepared you may light them, carry them, and throw them, where you please, and need not fear that either Wind or Rain will extinguish them; for on the contrary they will burn either upon or in Water with wonderful Rage to their utter Consumption, and never can be suppressed by any other means than by being buried either in Sand or Ashes.

C H A P. VIII.

Of FIRE-ARROWS or DARTS.

WHAT we here mean by *Fire-Arrows* and *Darts* where formerly called *Malleoli*, which some Authors confound with the Fagots and Torches, of which Number is *Nonius Marcellus*, who says: *The Malleoli are little Bundles of Broom, which being daubed over, or dipped in Pitch and fired, are thrown upon the Roofs of Buildings.* *Festus* is to the full as much mistaken; says he: *Not only small Mallets are called Malleoli; but those also which are contrived to set fire to Buildings, and are made after the Fashion of the Firſt.* But *Herodianus* explains himself much better when he speaks of the Form of the *Malleoli*; tho' by the way he confounds them a little with the *Torches*, for he speaks thus of them in *Lib. viii.* where he gives an Account of the Siege of *Aix.* *But the Machines being advanced, they threw Torches at them, which were coated over with Pitch and Rosin, with a sharp Point at the Ends of them; and which being lighted and thrown, stuck in the Machines, and easily burn'd them.* But of all the Authors I ever perused, I never met with any, that gave a more pertinent and rational Description of them, than *Ammianus*, who writes to this Effect. † *The Malleolus, a kind of Arrow, is formed thus: It is an Arrow made of Cane, which between the Cane or Reed, and the*

† *Ammian. Lib. XXIII.*

Head, or Point, is armed with an Iron several times doubled, and made like a Woman's Distaff: The Belly of it is finely hollowed, and it is laid open or pierced in several Places, and the hollow Trunk of it being filled with Combustible Matter, and fired, and shot easily from a large Bow (for if it be violently dismissed, the Fire of it will be extinguished) it will burn whatever it sticks in; and if Water be thrown upon it, it only serves to make it burn the fiercer, nor is there any means of suppressing it, but by the Superinjection of Duft. The Parenthesis in this Quotation, in which he gives us to understand that a violent Agitation or a swift Flight would put out the Fire of the *Malleolus*, may give us an Idea, of how much it stood in need of our *Saltpeter*, and *Gun-powder*, whose Fire is Proof against all Attempts of Wind or violent Motion, and is so far from being impaired by either of them, that they only serve to irritate it the more. Again; *Vegetius* speaks of the *Malleolus* almost to the same Purpose, namely, * *The Malleoli are like Arrows, and because they carry Fire with them, they burn whatever they stick in.* *Æne:* a very Ancient Author calls them simply *Fire-Arrows* or *Darts*, as may be learned from *Isaac Casaubon's* Translation of him into Latin, where he renders them *Sagittæ igniferæ*; *Igniferous* or *Fiery Darts*.

This is what I had to say of the *Fire-Arrows* or *Darts* of the Ancients: It now stands me upon to give you some Account of Ours, and to teach you the Construction and Preparation of them. You have three Sorts of them in *Figures* 222, 223, and 224. The Construction of the first of them is thus. Make a little Bag or Purse of the bigness of a Goose's or Swan's Egg, (which may be either longish or perfectly Round, as we formerly specified with Relation to *Fire-Balls*) and fill it with a *Composition* made of 4 lb of purified *Saltpeter*; 1 lb of *Sulphur*; 1 lb of *Meal Powder*; ½ lb of *Camphire*; and ½ lb of *Colophone*. Or else: take 2 lb of *Saltpeter*; 2 lb of *Powder*; 1 lb of *Sulphur*; ½ lb of *Colophone*. Or this Third *Composition* which is as good as either of the Two former (*viz.*) 8 lb of *Saltpeter*; 6 lb of *Powder* and 4 lb of *Sulphur*. Having filled your Bag, bore an Hole thro' the Body of it; through which you must run a common Arrow or Dart, in such Manner that all the Head or Iron may project out beyond it; then right under it drive a Wooden Peg athwart the Substance of the Arrow, or else stop it with two or three Nails that it may be immoveable, and in no danger of slipping down to the Feathers during the Flight of the Arrow, or when the Head of the Arrow strikes against any Resisting Object.

This done; lace it as you see in the *Figure*, and after the Manner we formerly specified in speaking of *Fire-Balls*; and coat it over with Pitch mixed with a little *Meal Powder*, and fire it by two small Vents, near the Head of the *Arrow*, and shoot it where-ever you please with a common Bow or a *Cross-Bow*.

* *Veget. IV. Cap. xviii.*

Of the two other *Darts*; that which you see in *Fig. 223* has a Concave Spherical Head, which usually incloses a *Hand-Grenado* or a *Fire-Ball*. In short, the Third has a certain Box or Cartouch at the End of it, which is to be filled with 'one of those *Compositions* we have given you in the preceding Part of this *Chapter*. The curious *Pyrobolist* will find more of them in *Brechtelius, Part II. Chap. III.* In *Ufanus, Treatise III. Chap. XXIII.* In *Hanzelet, Page 162.* In *Jerome Russel, Page 48,* and in several others who have amplified pretty prolixly upon this Head.

The Sequel of this *Chapter* shall illustrate the Use of *Fire-Darts*; which indeed are not greatly in Esteem with us, and are, by some shallow-witted Persons, held to be but aukward Contrivances for conveying Fire into any Place; but perhaps they are disliked, because there has been no Opportunity of using them in our Modern Sieges. However this be, we are informed by *Ufanus* (in *Treat. III. of his Artillery, Chap. XXIII.*) that the *Spaniards* found very successful Service from them at the Sieges of *Tpres* and *Ostend*: But were I to trace up the History of these Weapons a little more remotely, I might produce an infinite Number of Examples to convince you that their Utility is admirable, and their Service by no means despicable. But not to swell out this *Chapter* with the copious Evidence I could introduce; I shall content myself with what *Martin Cromer* relates; who speaking of the mighty Exploits of the *Poles* before the Town of *Choinice*, besieged by King *Casimir* in the Year 1466, N. S. writes thus: *Not long after our People* (meaning the *Poles*) *shot Fire-Arrows into the Town under the Cover of the Night, by which Means one Quarter of the Town was reduced to Ashes, and all their Wheat destroyed.* You will find a thousand Examples of this Kind in other Authors. But if ever they can be used to any very great Purpose, it must certainly be in Sea-Fights, to set Fire to the Enemy's Sails and Rigging, and especially when they are headed with a sharp Iron. In truth, I believe there can be no Weapon more pernicious upon such Occasions than these; for if they once stick in the Sails, &c. it will be very difficult to pull them out again; so that they must burn on without Interruption; and it would be impossible to extinguish them without clewing up the Sails; during which I leave you to judge, whether or no an Enemy might not easily board, and overpower a Ship's Company, which is under the confused Apprehensions of seeing their Ship either burnt, or disabled; for (pray) what is any Vessel (which does not go with Oars) when stripped of her Sails, and in the midst of an Engagement, but a Bird without Wings, a Man without Hands or Feet, or a Body without a Soul? In fine, all these *Arrows* may be shot into besieged Places without being fired; thereby to surprize the Inhabitants the more, when they shall see such sudden and unexpected Ruin falling upon them: But to do this artfully, you must stick little pieces of lighted Sponge (such as we taught you to prepare in *Book II. Chap. XXVIII.*) into the Vents of your little Bags of



Fig. N° 207.

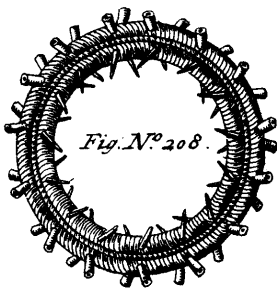

Fig. N° 208.

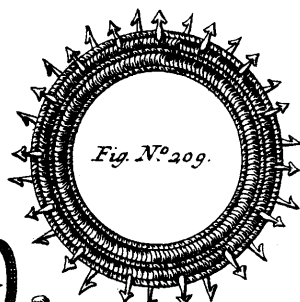

Fig. N° 209.

Fig. N° 211.

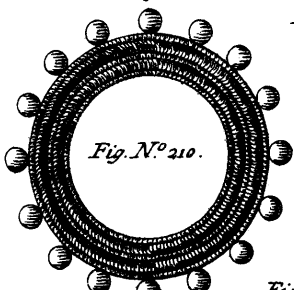

Fig. N° 210.

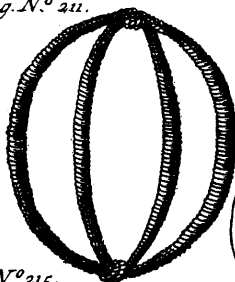

Fig. N° 215.

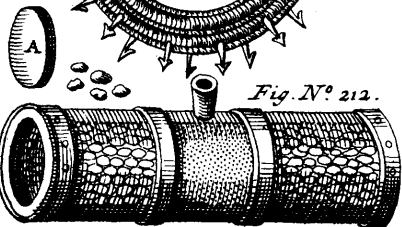

Fig. N° 212.



Fig. N° 213.

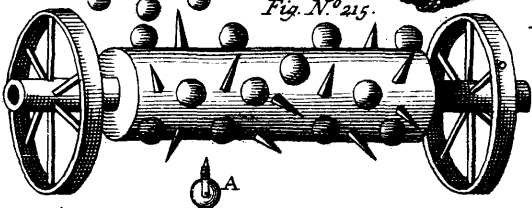

Fig. N° 216.



Fig. N° 214.

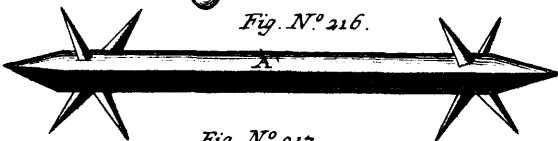

Fig. N° 217.

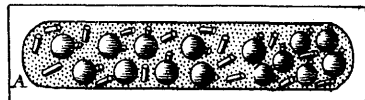

Fig. N° 219.

Fig. N° 220.

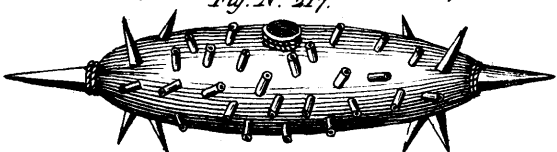

Fig. N° 218.



Fig. N° 223.

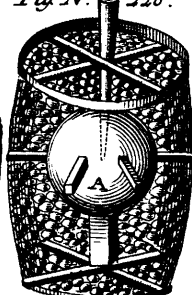

Fig. N° 222.

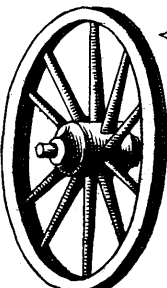

Fig. N° 221.

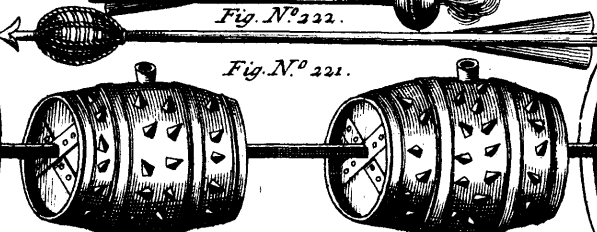

Fig. N° 224.



Fig. N° 226.

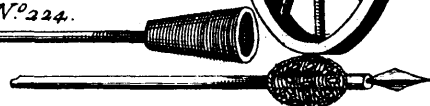

Fig. N° 229.

X

Composition, or into the Vents of the two others; the Use, and ^{*}Necessity of which will come to you by Experience.

CHAP. IX.

Of FIRE-LANCES or PIKES.

OUR *Fire-Lances* are not unlike a Sort of long Javelins, which were anciently called *Phalaricæ*, and were usually shot at the Enemy by *Engines*, or thrown by Hand. Hear what *Vegetius* says, concerning the first Way of projecting them : *That if the Inhabitants dared not stir out, they the more outrageously defended themselves with Malleoli and Phalaricæ, which they shot flaming from the Balista.* We shall speak of the second Way of dismissing them a little lower. Let us first see what we can gather from Authors concerning the Form, Preparation and Effects of them. The above-quoted Author, after having described the *Malleolus*, writes to this Purpose. † *The Phalarica is a kind of Spear, armed with a great Iron Head, between which and the Staff it is wrapp'd round with Rosin, Bitumen, and Tow steeped in Oil which is called Fiery; and being shot from the Balista, sticks in any Wooden Works, and frequently sets Fire to the Machina Turrita.* *Titus Livy* tells us, that the *Phalarica* was properly a *Saguntine* Weapon. ‡ *The Saguntine Phalarica was a Projectile Javelin with a long Staff, being armed with Fire (Tow and Pitch) and an Iron Head of three Foot in Length; that it might penetrate through any Armour, and pierce the Body, and that if it only stuck in the Shield, and did not hurt the Body at all, it might create Fear.* *Lippius* adds to this Passage in *Livy* : *This is a terrible Weapon, both in the Blow it gives, and to look at; however, what was it but the Lightning that preceded our Modern Thunder?* *Silius* also mentions the *Saguntine Phalarica* from *Livy*.

*Armavit clausos, & portis arcuit hostem,
 Librari multa consueta Phalarica dextra,
 Horrendum visu robur, celsisque nivosa
 Pyrenes trabs lecta jugis cui plurima Cuspis,
 Vix muris toleranda lues, sed cætera pingui,
 Uncta pice, atque atro circumlita sulphure fumat.
 Fulminis hac ritu summis è mœnibus arcis
 Incita sulcatum tremula secat aera flamma.*

In *English* thus :

With a *Phalarica*, whirl'd by many Hands,
 The brave Besieg'd repell'd the hostile Bands,

† *Veget. Lib. IV. Cap. XVIII.*

‡ *Decad. II. Lib. I.*

Back from their Gates. It was a mighty Oak,
 Strange to behold; which for Defence they took
 From th' *Pyrenean Hills*. This arm'd around,
 With bearded Spikes of Steel, would scarce have found
 Obstruction from firm Walls. The rest besmear'd
 With Sulphur, and with unctuous Pitch, appear'd
 Like a dire Thunder-bolt, and from the Walls
 Of their strong Ramparts down it swiftly falls,
 Cutting with Quivering Flames the yielding Air. Roff.

Lucan also in his *Pharsalia*, *Lib. VI. vers. 196*, mentions the *Phalarica* after a very Poetical Manner.

The Majestic *Virgil* sings as follows of this frightful Weapon, in *Book IX.* of his *Æneid*.

*Non jaculo neque enim jaculo vitam ille dedisset,
 Sed magnum stridens contorta Phalarica venit,
 Fulminis aëta modo, quam nec duo taurea terga,
 Nec duplici squamma lorica fidelis & auro,
 Sustinuit; collapsa ruunt immania membra:
 Dat tellus gemitum, & clypeum superintonat ingens;*

In *English* thus:

Not by the feeble Dart he fell oppress'd,
 A Dart were lost within that roomy Breast.
 But by a *Phalaric*'s, large, heavy, strong;
 Which roar'd like Thunder as it whirl'd along.
 Not two Bull-hides th' impetuous Force withhold;
 Nor Coat of double Mail with Scales of Gold.
 Down sunk the Monster-Bulk and press'd the Ground,
 His Arms, and clatt'ring Shield on the vast Body found. Dryden.

Servius commenting upon this Passage in *Virgil*, gives us a particular Account of the Construction and Form of this Weapon. *It is a large Arrow turned in a Leath, with an Iron Head of a Cubit long, at the End of which is a kind of Ball laden with Lead: It is said to have Fire added to it by means of Tow steeped in Pitch; and being inflamed, destroys the Enemy by the Wound it gives, or the Fire it carries along with it. This Spear was thrown from Towers which were called Phalæ, from whence it was termed a Phalarican Arrow or Javelin, to distinguish it from the Mural Arrows which were shot from Walls.*

Tacitus in many Places calls them *Hastæ Ardentès*, or *Fire-Lances* or *Pikes*; which Appellation of them we retain, by the common Consent of all *Pyrotechnicians* and *Pyrobolists*: For the *Italians* call them *Dardi de Fuoco*; the *French*, *des Lances & Piques a Feu*; the *Germans*, *Fewer Picken*; the *Flemings*, *Vyer-Spiffen*; and in short, we (the *Poles*) call them *Ognistæ Wlocznie* or *Kopie*.

If you would see the Fashion of our *Fire-Lances*, please to cast your Eye upon *Fig. 229*. As for the Construction of them, it is the same I *Fig. 229* directed for the *Fire-Arrows* and *Darts* of the first Kind: There is only this Difference between them, (*viz.*) That these are armed with a good Number of *Iron Crackers* prepared after the common Method; in which Respect they far exceed the *Phalaricæ* of the *Ancients*: Or on the contrary it is in Respect of this, that the *Phalaricæ* exceeded our *Lances*; for we should find it a most difficult Matter to shoot them when prepared after our Way from our *Artillery*; as the *Ancients* were used to do from their *Balistæ* and *Catapulta*, as appears by the Testimony of the Authors above-quoted.

But on the other hand we have *Fires* that are more Artificial than the *Phalaricæ*, and which we can project from our *Cannon*, *Mortars*, &c. With these *Lances* we commonly arm our Men in Attacks and Storms, and in boarding of Ships: And indeed it is a terrible Weapon, if we rightly consider the horrid Execution it does; for only imagine that a Soldier who carries one of them is armed with as many *Pistols* as his *Lance* has *Iron Crackers* in it; and consequently when he is thus armed, he must do as much Mischief as several Musqueteers. Farthermore, it must be considered that these *Lances* may not only annoy and gall the Enemy with *Powder* and *Ball*, but also knock them down, and gore them with the Staff and Head: Add to all which, that if the Effort be made, or the Attack carried on in the Night, they will serve to give a Light, by which may be discovered any lurking Ambuscades of the Adverse Party.

C H A P. X.

Of MILITARY FIRE-CASES.

I Here give you only one Sort of the *Military Fire-Case*, which you have in *Fig. 226*; and which in point of Form is exactly like the *Fig. 226*, *Recreative Case* in *Fig. 195*. And for my part, I cannot see why we should not apply our *Recreative Cases* to Military Uses; by stripping them of their innocent and diverting Nature, and in the Stead of that, substituting something of destructive Effect, (*viz.*) *Hand-Grenado's*, *Crackers*, &c. as you may observe in the *Figure* itself, where instead of *Paper Crackers*, I have firmly fix'd others of Iron. These differ from the *Recreative Sort* in another Respect, (*viz.*) That they are portable, as well as the *Fire-Lances* above-described. Upon the whole, I shall only remind you, that all these *Crackers* are to be fix'd so as to discharge themselves directly upon the Enemy.

CONCLUSION and APOLOGY.

Here (Candid Reader) you have the first *Essay* of my *Artillery* completed; which I have performed with all the Care and Accuracy the
Weak-

Weakness of our Nature would permit. If you and other worthy Persons can collect any thing useful from it; I shall never repent me of the Trouble and Expence I have been at, nor of the great Portion of my most valuable Time which has been taken up in the Prosecution of this *Work*: But very far to the contrary; if I could know, that my Labour meets with a kind Acceptance from you, your Approbation would excite me to attempt something of a more exalted Nature, and more worthy of you: All this is but the Prelude to what I meditate, if it be the Will of Heaven to second my Design. I indeed must own, that I have omitted a great many Things in this little *Work*, as well in the *Recreative* as *Serious Part* of it; but it was through a Contempt of them, and not ignorantly that I passed them over; or some of them I thought fit to lay aside for another Opportunity, and for other Reasons; to which I might add the Importunity of the Printer, who would never let me rest. In sum, if I have any where fallen into Error, or if I have not given all the requisite Graces and Embellishments to some particular Subjects (in which I know myself to have been often wanting) I ask your Pardon for it. I am neither afraid nor ashamed of Reprehension, if it be given in a Friendly Manner: But as for rancorous *Critiques* (the Spawn of Envy and Ill-Nature) I laugh at them, instead of railing. But whither am I running to? Would it not have been more prudent in me to have restrained my Pen, and by my Silence to have preserved the good Opinion my Friends had conceived of me; than to give into such Flights, with Relation to an Affair in which many *Arts* and *Sciences* are concern'd; amidst the Multiplicity of which, it is not impossible but I may have been bewildered, and at a Loss; and consequently have laid myself too open to the ungenerous Attacks of the *Malevolent*? Yet all this gives me no Trouble; for I hope, my real Friends will have it in their Power to suppress the Calumny, and repel the unmanly Efforts of the *Ignorant* and *Errourous*; with whom it were to no Purpose to contend, except I put myself upon a Level with them. In a Word, no overweening Fondness of my own Productions can ever blind me so effectually as to prevent me from being convinced of their Imperfections; I know and confess that I am but a Man, and consequently subject to err; and to say the Truth, all Human Performances are very copiously interspersed with Folly, Rashness, Superstition, &c. and amongst them I am very well contented that mine should be ranked; To speak and conclude with *Scaliger*;

To the Beginning without Beginning; to the End without End; to the Day without Night; to the Workman without Hire; to the Creator without Expence; to Knowledge without Discipline; to the Triumpher without War; to Perpetuity without Moments; be ascribed all Praise, Might, Majesty, and Dominion, both now and for evermore.

F I N I S.