

## TRADITIONAL CYLINDER SHELL CONSTRUCTION

### Part II

A. Fulcanelli

*Sic facies tonitruum et coruscationem,  
si scias artificium.*

Roger Bacon, *De nullitate magiae*

### MULTIPLE BREAK SHELLS

#### Introduction

The multiple break shell, consisting of one projectile fired from the mortar giving rise to several bursts of stars or garnitures opening in close succession, often concluding with a heavy report, is characteristic of the Italian style. It takes advantage of the cylindrical construction, which lends itself well to the stacking of cylindrical breaks, or the elongation of a cylindrical case to contain more components; whereas the spherical style, favored by the Oriental pyrotechnists and by the old northern European practice, inherently limits the contrivance of such effects.

Having succeeded at making single-break shells of cut stars, comet shells, single-opening effects consisting of special garnitures in combination with cut stars, and single-fire reports, the shell-builder will wish to proceed to making shells in multiple breaks. The basic method of case-rolling and filling, spiking, pasting in, and shell finishing are the same. The techniques that must be learnt have principally to do with the assembly of the succeeding breaks, and with the use of spolettes as timing elements between breaks. However, because multiple break shells are always heavier and longer than single-break shells of comparable diameter, they are subjected to more strain in being fired from the mortar; accordingly, the mastery of the basic methods of filling, spiking, pasting, etc., will be subjected to a more severe test.

Problems in the performance of multiple break shells usually fall into two categories: if the shell malfunctions at some time between firing and the opening of the first break (i.e., flowerpots, goes blind, breaks up after leaving the gun), the problem lies with basic methods; if it fails in the succession of the breaks (i.e., successive break goes blind, two breaks open at once), the problem may be laid to some defect in the special manipulations appurtenant to multiple break shell construction.

In view of the coverage of basic methods in Part I, as well as the difficulty of presenting (and learning) the special multiple break techniques as *general principles*, Part II presents *specific examples* of multiple break shell building technique, which may be followed to produce the desired effects. Knowledge of the basic methods is presumed in order to eliminate repetition, and as more complex effects are achieved, building on

the experience of making the simpler ones, the shell builder will develop an awareness of the general principles involved.

#### COLOR AND REPORT

The simplest and easiest multiple-break effect is a single burst of colored stars followed by a heavy report. This effect is always achieved by enclosing a salute, completely spiked and pasted, at the bottom of a longer shell case, the upper part of which is filled with burst powder and garniture, and closed with the usual fused disc. This assembly is then spiked, pasted in, and finished as if it were an ordinary shell of one break — which is, indeed, how it appears from the outside. The main time fuse passes fire to the burst powder and garniture just as it would in a single break shell, but at the same time ignites the time fuse of the salute, which after an appropriate time passes fire to the flash powder, exploding the salute.

Two variations of technique exist. The first is to make the salute or report either with a spiral wound can, as described in Part I, or by hand, and to roll up the long case to enclose it and the color break right on the report. The second is to place a report smaller than the inside diameter of the long shell case in the bottom of that case and to surround it with rammed sawdust. The method for making hand-rolled reports will first be given, followed by three examples of different color and report techniques.

#### HAND-ROLLED REPORTS

While 3" and in some cases 4" reports for bottom shots may handily be made using the spiral-wound cases in common use, bigger shells call for bigger reports, and the cases for these are generally made by hand because not enough demand exists to make spiral-wound cases an economical proposition. The hand-made salute differs from the spiral-wound type in many respects. It consists of an inner case or bag of two turns of light kraft paper, over which is rolled a heavy core, made either of strips of chipboard or of newsprint folded in a special way. Around this is rolled a kraft paper casing just as for a color shell. The flash powder is filled in the inner bag. The ends are formed with chipboard discs over which is pleated the outer kraft casing, also similar to the manner of making a color shell. Outer chipboard discs are placed over the pleated ends of the case, similar to a color shell, and

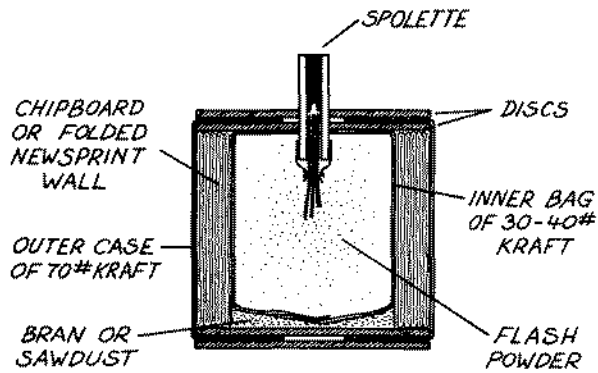

Figure 36. Hand-made report.

Table 17. Dimensions for formers and discs for hand-rolled reports.

Report size for bottom shot	Size of former	Size of discs
3"	1 3/4"	2 1/2"
4"	2 - 2 1/4"	3 1/2"
5"	2 1/2 - 3"	4 1/4"
6"	3 1/2 - 4"	5 1/4"
8"	4 1/2"	7"

the report spiked and pasted in as appropriate for a shell of its size. Figure 36 illustrates a cut-away view of a hand-made report.

As it will be seen, the dimensions of the discs for the larger reports are smaller than the discs used for the shells themselves. The reason for this is that because the report functions as the former on which the color break case is rolled, allowance must be made for the increase in size from spiking and pasting of the report.

The height of the report may be variable, and it is not crucial that it be as high as its diameter. Particularly in the larger sizes, and when the shells to be made are of many breaks, the report is made short and squat relative to its diameter.

If chipboard strips are to be used for forming the wall, they may simply be cut to the width of the desired wall height (making allowance for the thickness of end discs, string, and pastewrap). However, if

folded newsprint is to be used, the procedure is as follows. Obtain and lay flat a supply of full-size (journal) newsprint. Tabloid newsprint is too small for large salutes. Fold the sheet or sheets (two or three thicknesses may be folded together, as deemed necessary) first on an angle, making a trapezoidal shape (Fig. 37.1). This trapezoid is then folded up along the diagonal edge — in effect, rolling it, but in a flattened condition — into a strip of the desired width (Fig. 37.2). This strip will, as it may be seen, be of variable thickness along its length, since more thickness will build up in the center than at the edge. In effect, it is like a strip of feather-edged paper or skived leather, and when rolled up on the former, will lie smoothly and have no evident seam (as, for example, would a strip of thick chipboard).

Prepare a supply of such folded strips. Since the thickness of each strip is inversely proportional to the width to which it is folded, it is impossible to tell how many will be needed to roll a wall of the desired thickness, and it will be necessary to find this out by trial and error.

The former should have a hole made in one end to accommodate the matched, nosed end of the spolette as the report is built fused-end first. Begin by taking two turns of light (30-40 lb.) kraft on the former, of approximately three times the width of the desired report wall height. Secure with paper tape or paste and slip the tube thus formed up over the end of the former by a full diameter. Close this end with the triangle fold. The fold may be held down with a drop of paste or glue. Now, begin rolling up the chipboard or newsprint strips over this light paper tube. Roll tightly and continue adding strips until the diameter of the assembly is built up to that of the disc prescribed in Table 17.

When this point has been reached, secure the end of the last chipboard or newsprint strip with paper tape or glue, and roll over the core the number of turns of 70-lb. kraft required for a shell of the nominal diameter of the report; e.g., three for a 3", four for a 4", etc. (see Part I, pp. 14-15, and Table 7, PYROTECHNICA • IX). This kraft should overhang the

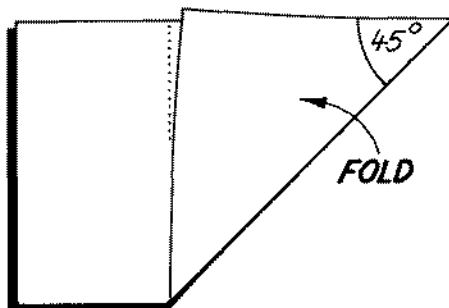

Figure 37.1

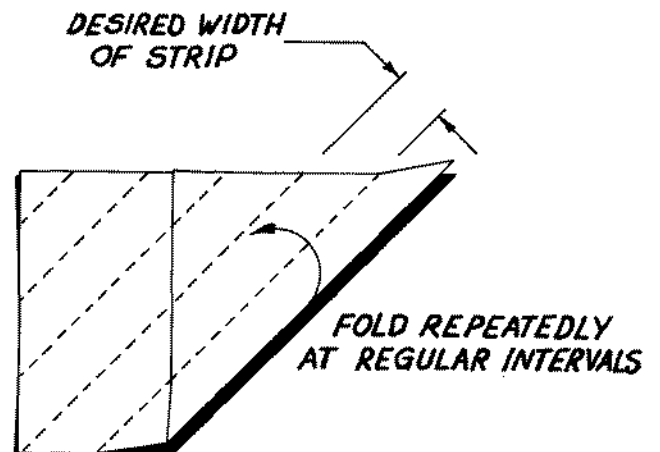
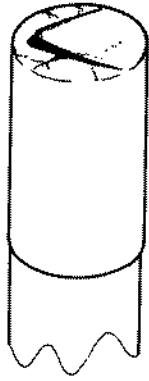

Figure 37.2

Figure 37. Folding paper for hand-rolled reports.

PYROTECHNICA • XI



1. INNER BAG  
OF 2 TURNS  
30-LB. KRAFT

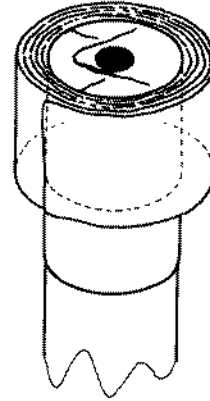

2. CORE FORMED  
OVER INNER BAG -  
HOLE CUT IN END

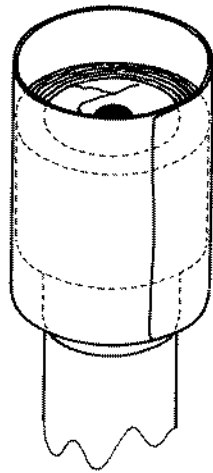

3. OUTER KRAFT  
ROLLED OVER CORE

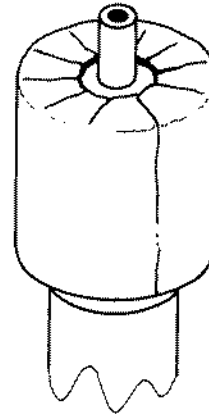

4. FUSED DISC  
INSERTED - KRAFT  
PLEATED DOWN

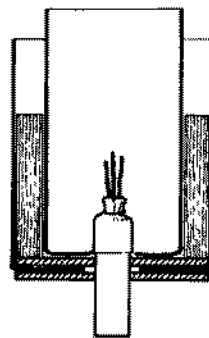

5. CROSS SECTION OF  
CASE REMOVED FROM  
FORMER READY TO FILL  
WITH FLASH POWDER

Figure 38. Forming cases for hand-made reports.

ends of the core by a little less than half a diameter on the top (fuse) end, and by half or even a full diameter (if the tongue fold is to be used for closure) on the bottom. Now, make a hole in the inner paper bag so that the matched end of the spolette can pass through it; insert the fused end disc so that it is seated firmly against the former end and the turns of chipboard or newsprint. Fold the overhanging kraft down onto the disc, and slip another punched end disc over the spolette down onto the folds. The assembly may now be slipped off the former and turned, fuse end down, into a hole in the work surface. Now the flash powder may be charged into the inner bag. When this is filled to a level just below the edge of the chipboard or newsprint core, the open end of the inner bag should be folded down onto the flash powder. The space above this is filled, level with the core, with bran or sawdust. A solid end disc is slipped down over this and the overhanging kraft pleated down.

At this point, the assembled report will look like an ordinary shell of one break, and is spiked (spiking on the bottom disc), given a good seal of glue around the spolette, and when this is dry, pasted in. The spiking is in accordance with the normal pattern for a shell of the given size (see Part I, Table 10, p. 20, PYROTECHNICA • IX), and the pasting is also (Part I, Table 11, p. 21).

When the pasted report is dry, it may be used as a bottom shot, or, in the rare event it is needed, as a single-fire salute (given appropriate lift and spolette timing). Figure 38 shows the procedure of case rolling and filling step by step.

#### First example.

#### Construction of 3" color and report shell

Prepare a 3" salute as described in Part I, using a spiral wound can approximately  $1\frac{3}{4}$ " inside diameter,  $2\frac{1}{2}$ " outside diameter, and  $2\frac{1}{2}$ " long. For the time fuse, use a spolette made with the usual tube for a 3" shell, as described in Table 5, Part I ( $5/16$ " inside diameter,  $.550$ " outside diameter, 2" long). However, the powder charge should be only  $\frac{3}{4}$ ". The spolette should be scratched back, matched, and nosed as described for any spolette.

The salute should be spiked with vertical spiking only, 12 strings, as described in Part I. It is imperative that after spiking, the area around the base of the spolette, where it passes through the hole in the top disc, be well sealed with glue. After the glue has dried, paste the salute in using a sheet of 40-lb. kraft paper,  $7\frac{1}{2}$ " wide by 24" long. The pasted paper should be

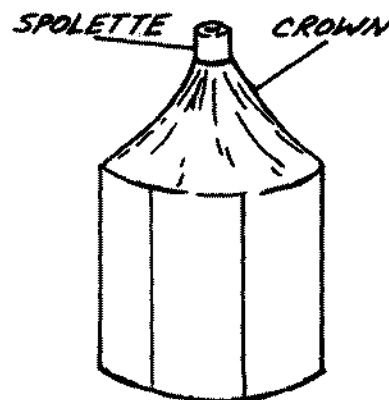

Figure 39. A "bottom shot" showing heavy crown.

twisted around the spolette one turn at a time, as it is rolled onto the salute. Let the paper lap well up around the spolette. After pasting, the crown of the salute should appear almost conical, as depicted in Figure 39. The purpose of the heavy glue seal and the heavy crown is to provide extra assurance against fire getting to the flash powder prematurely. As will be appreciated from the description to follow, pressure and heat from the burst powder of the color break bears directly against the crown of the salute — which is not the case in a single-fire shell, where the crown is normally away from the lift. Accordingly, the secure sealing around the spolette of a salute destined for the construction of a color and report shell (or, as such a salute is often called, a "bottom shot" or "counter-report") is absolutely essential.

After the pastewrap has dried on the report, the spolette must be matched. Scrape the exposed powder on the end of the spolette to remove any residual paste and to roughen it, just as when preparing a shell for lift and leader. Cut two pieces of thin match 3-4" long. Holding these on one side of the spolette, bend them together over the top, down the other side, and back up so that the two pieces point up, resembling "rabbit ears." The form of the match over the top of the spolette has been variously likened to a chair, a lower-case "h", and a stairstep. This match must now be firmly tied in place. It is advisable to paste the

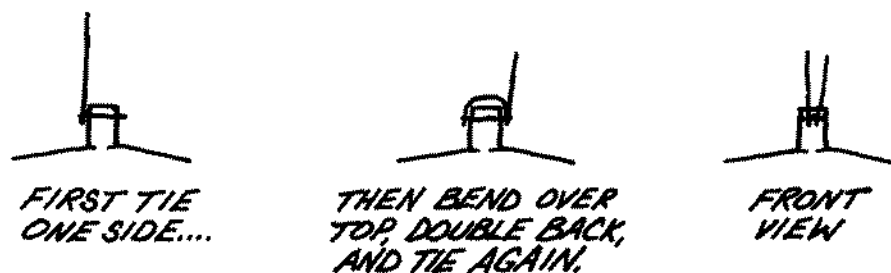

Figure 40. Tying match over spolette of bottom shot.

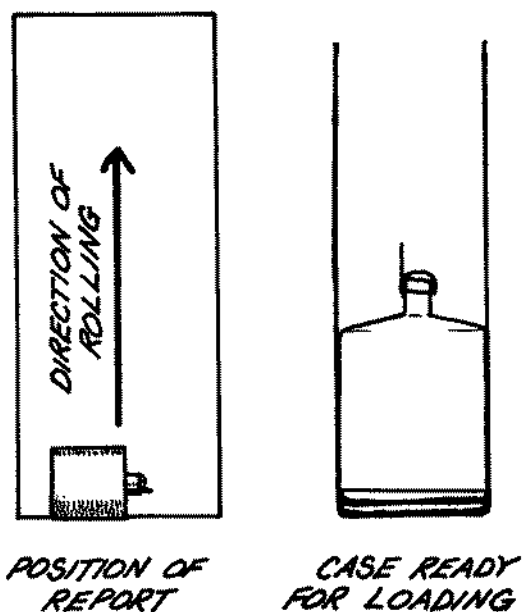

Figure 41. Rolling color case on bottom shot.

string or to rub it with a lump of roofing tar while putting it on the spiking horse. It cannot, then, once it is drawn tight, slip from place, permitting the match to fall off the spolette of the report. Figure 40 illustrates the appearance of the matched spolette.

Cut a strip of 70-lb. kraft paper at least 8" wide (9" if desired to close the bottom with a tongue fold) by 24" long. Lay the report at one end of the sheet, along the narrower width, so that perhaps 1½" or a little more overlaps the bottom end of the salute, and the balance covers the sides and overlaps the top. Enough should overlap the top, in any event, to allow 2½" for the colored stars and sufficient paper to pleat down around the top disc. The grain of the paper should be oriented along the narrow width of the

sheet, i.e., the axis of the salute. Roll the paper up tightly around the salute just as if rolling a normal shell casing, and paste the final edge. Invert the case so that the bottom of the report faces up. Sprinkle a little sawdust or bran, sufficient just to fill in any irregularities at the bottom of the report. Some workers at this point prefer to press a solid end disc in over the sawdust, then fold the overlapping paper down; others simply fold the paper in without a disc. Set the folds by pounding with a mallet, in the fashion well known. Figure 41 illustrates these steps.

Setting the case upright, with the fused and matched end of the bottom shot pointing upwards, slip a canulle of the appropriate diameter (¾" is suggested) down over the spolette of the report. Around the canulle, fill stars as usual for a single-break shell, to a depth of about 2 to 2½" from the top of the report (regarding that as the bottom of the color break). Fill the canulle with FFA powder, withdraw it, and level off the top of the break with rough powder as usual, patting, shaking, and tamping to consolidate the stars. Close the break with a fused disc using a spolette made with the usual powder charge for a 3" shell (1" to 1¼"). Pleat the paper down over the disc, set the folds with the mallet, and push another disc down over the fuse to complete the top of the shell.

Spike, beginning as for any shell, with the vertical strings (12 passes of 2 strands of 8-ply cotton for a 3" shell), spiking on the bottom disc with the first pass. When the vertical spiking is complete, bring the string down diagonally on the side of the shell, not to the bottom, but only to the bottom of the color segment of the shell (string is not required to strengthen that area of the shell where the report is located). Commence running the string circumferentially, making little squares on the sidewall, until the top is reached. There the string should be tied off using the usual half-hitch around the body of the shell. Figure 42 shows the inner construction of the shell as well as its string pattern.

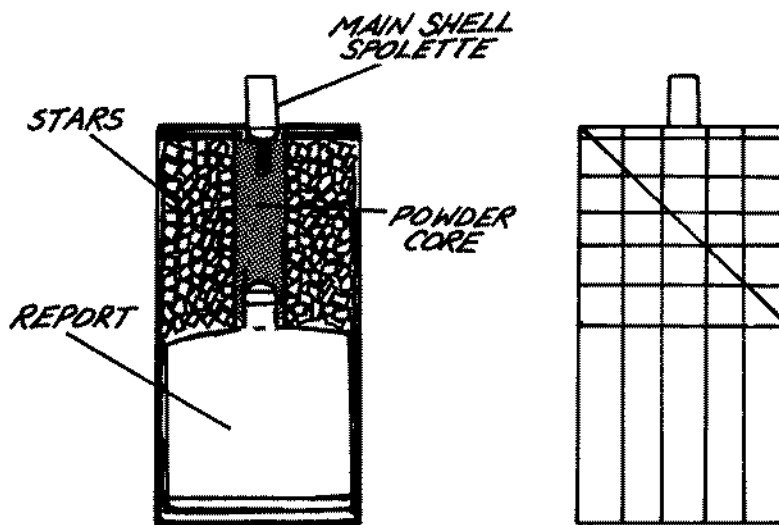

Figure 42. Cut-away view and spiking pattern of 3" color and report shell.

Paste in using a 24" strip (approximately 3 turns) of 40-lb. kraft. After drying, finish with the usual procedure for lift and leader, using 1½ oz. FFA powder for the lift charge. If successful, the shell described should open with a burst of color like a normal 3" shell, followed about two seconds later by a heavy report.

#### Second example.

#### Construction of 4" color and report shell

Prepare a 3" salute for use as a bottom shot, just as in the example of the 3" color and report shell. Again, use a spolette having a powder charge of ¾". Match the spolette on the outside as shown in Figure 40. Cut a 48" strip (or 2-24" strips) of 70-lb. kraft 9 to 10" wide, with the grain the narrow way of the strip. Roll up a long case on the usual 3½" former used for 4" shells, pasting the edge. Slip the casing partway off the former, inserting a solid end disc and pleating the bottom down or closing with a tongue fold as preferred. Remove the casing from the form and place upright on the workbench.

Lower the bottom shot into the long shell case, centering it on the bottom disc. A useful technique for keeping it in the center is to cut three or four 7/16" or ½" wooden dowels to about 8" lengths, inserting these at approximately equal intervals around the circumference, between the inside wall of the shell case and the sides of the bottom shot. Since the report is 2½" in diameter, and the inside of the case is 3½" in diameter, these dowels maintain the same space all the way around the report. Now, placing a canulle of the appropriate diameter (1" is suggested) over the matched end of the spolette to protect it, and to hold the report firmly against the bottom disc of the case, shake a good handful of dry sawdust around the walls of the report. Using another dowel, ram the sawdust firmly in the space between the report and the case walls. It should compact down to half the height of the report or less, and hold the report well in place. At this point the three or four spacer dowels that were used initially to hold the report in place may be removed. Still holding the canulle in place over the

report spolette, add another handful of sawdust and ram again. Continue adding and ramming more sawdust until it is flush with the top of the report wall, leaving only the crown of the report and the spolette exposed. Figure 43 illustrates these procedures and their result.

Before proceeding any further, feel the area rammed with sawdust by squeezing it. If it shows any tendency to be spongy or to give, further ramming is necessary. It is crucial to the integrity of the shell that the sawdust be well and firmly rammed, since it is this area — the bottom of the shell — that receives the brunt of the explosion of the lift charge.

Assuming the sawdust to be acceptably compacted, the shell may now be filled with stars and burst powder, the top leveled off with rough powder, and closed with a fused disc using the usual spolette for a 4" shell, charged with 1" to 1¼" of powder. Spike with the normal number of vertical strings (16 passes of two strands of 8- or 10-ply cotton) for a 4" shell; then spike circumferentially over the color segment only, making little squares on the sidewalls, as illustrated in Figure 42. Paste in with four turns of 60-lb. kraft, or approximately 48". After drying, finish with the usual lift and leader procedures, using 2½ oz. of FFA powder for the lift charge.

The rationale for using the 3" salute as a bottom shot in a 4" color and report shell, surrounding it with sawdust as described, has principally to do with cheapness and convenience. It is evident that a 3" salute uses less flash powder and takes less time to make. Standard 2½" outside diameter spiral wound salute casings are more readily available than spiral wound cans of 3½" diameter, as well as less expensive; this is the consequence of greater demand for 3" straight fire salutes than for 4" or larger sizes. The alternative would be to make hand-rolled casings, which is still more laborious. From the directions for the above 4" shell it will be readily understood that 5" color and report shells can be made using 3½" outside diameter spiral wound salute casings, and that 6" color and report shells can be made using 4½" outside diameter

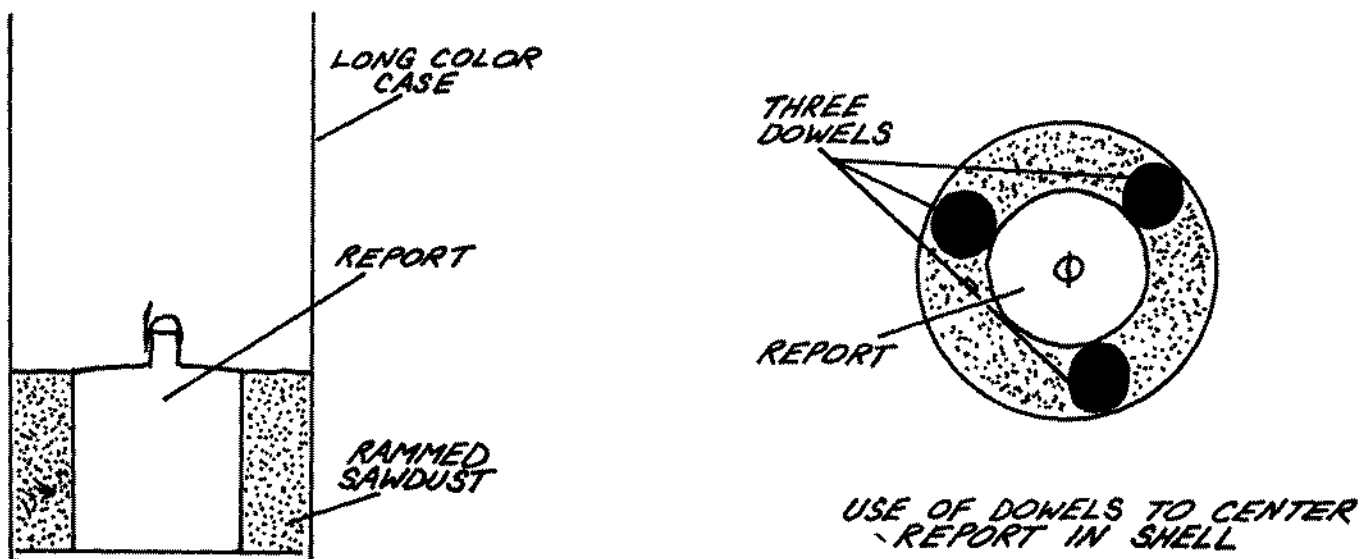

Figure 43. Ramming sawdust around the bottom shot.

salute casings, assuming such to be available. It is also possible to use a thicker increment of sawdust between the shell casing and a report. In an effort to cheapen the product, some manufacturers use 3" salutes in 5" and 6" shells. The disadvantage to this lies in that a great thickness of sawdust is even more difficult to compact reliably than the ½" or so allowed in this example.

The often-made claim that the sawdust improves safety and protects the salute from detonation by shock has no basis in fact. In actuality, loosely rammed sawdust which might have some "give" or cushioning effect is more likely to lead to a flowerpot as the shell collapses under stress. When the sawdust is properly rammed and hard, it should have no dampening effect on the shock of the lift explosion. Any flash powder likely to detonate from the sort of shock it would receive in a shell has no place in a shell to start with. Finally, the sawdust can have little value in preventing fire from getting at the shell's contents or at the report, since it would presumably have to get first through four layers of pastewrap and four turns of case wall (in the example of a 4" shell). Any shell construction which permitted this to happen would be so unsound at the base that successful performance would be unlikely in any event. Safety claims for sawdust smack of making a virtue out of economic necessity. The method is a valid and successful one, which is why it is fully described here. Any pyrotechnist contemplating using the method should be aware of the real reasons for choosing it.

### Third example.

#### Construction of a 5" color and report shell

Prepare a report using the hand-rolling technique previously outlined. The former may be the standard 2½" former for a 3" shell, and the newsprint or chipboard wall made about 3½" high. When the report is filled, closed, and spiked, paste it in first with three turns of 70-lb. kraft, overhanging both ends by a full diameter and torn down to "fork" around the spolette in opposing pairs on the top; allow to dry and paste with two turns of 70-lb. kraft, similarly overhanging. The resultant bottom shot should have a finely formed conical crown contributing greatly to its strength. The spolette for this bottom shot should have only ¾" of powder charged in it.

Because it will have been built on a 4¼" disc, this bottom shot may need to be built up with a few turns of heavy paper or chipboard rolled around its sides to act as a former for the color case. When it is built up so that a 4½" disc can fit snugly into a tube rolled around it, the report may be matched (as previously described) and the color case formed. This will require a 24" and a 48" strip of 70-lb. kraft, approximately 12½-13" wide. Roll these onto the report in just the same manner as the 3" shell described in the first example, allowing enough paper to overhang on the bottom for pleating down, and on the top to fill 4-4½" deep with stars and powder, plus the overhang to pleat down over the top disc.

Level the bottom with a little sawdust, insert an inner bottom disc if desired, and fold shut. The inner bottom disc should be used if only enough paper overhangs to pleat to the center. If only an outer bottom disc, over the folds, is to be used, the bottom closure

should be by tongue fold. Up-end the shell and lower a canulle of the appropriate diameter over the matched spolette of the bottom shot. Fill cut stars as desired around it to a depth of 4-4½", consolidating carefully with perhaps a bit of rough powder to fill the interstices. Fill the canulle with FFA, remove, and level the top with rough powder as for a single-break shell. Close with a fused disc having a spolette with 1¼" powder charge; pleat the overhanging paper down and complete with another punched disc over the folds.

Spiking is with the appropriate pattern of 24 vertical strings, and horizontal strings making little squares over the area of the color break. Pasting in is with six turns of 70-lb. kraft, for extra strength; one 48" sheet overhanging enough to come into the center and touch the spolette on the first pasting of three turns; then, on the second three turns, overhanging by a full diameter.

This is torn into six strips, and, on the top, each strip is torn approximately halfway down the center and the two halves "forked" around the spolette. The strips are laid down in opposing pairs, leading to the formation of an even crown.

When dry, weigh the shell, and allow one ounce of FFA powder per pound of shell weight in calculating the lift charge. Lift and leader are attached as usual.

### MULTIPLE BREAKS OF COLOR

It may well be imagined from the foregoing section on color and report shells that a similar means of producing successive breaks in color might be adopted. Instead of making and filling a report case, spiking and pasting it in, matching its spolette and rolling up a strip of paper on it to form the color break preceding the report, the only change that would be necessary would be substitution of a finished color shell for the report. Even more than two breaks in succession could be achieved by the simple means of spiking and pasting the assembled two breaks, and using the resultant two-break shell to form the case for still a third break, and so on until as many breaks have been assembled as are desired.

While some old books indeed show one shell within another, formed in this manner, to produce multiple successive breaks of color, this technique is not widely practiced among contemporary manufacturers of multiple break shells. The shell-within-shell construction is customarily reserved for color and report shells, or for the final color break and report of a shell of several breaks of color ending with a report. The method used to make successive breaks of color involves the stacking of one shell case upon another, with sequential filling and spiking, until all are assembled. The breaks are thus held together solely with string. The assembled shell is then pasted in, typically with somewhat more paper than would be used for a single-break shell, and from that point forward is finished as would be any other shell (taking into account in measuring lift powder its greater weight, and in cutting finishing paper its greater length). The following examples describe construction of multiple break shells of increasing levels of complexity and difficulty.

#### Construction of a 4" shell of two breaks of color

Roll up a shell case of normal dimensions for a 4" single-break shell, closing the bottom with a solid



end disc and pleating or folding the paper down over the disc in the usual manner. A paper strip 6" wide by 48" long of 70-lb. kraft should suffice for this case. Prepare a spolette using a powder charge of  $\frac{3}{4}$ ". It is indifferent whether this charge is rammed in the small (2" long x  $\frac{5}{16}$ " I.D. x  $\frac{550}{1000}$ " O.D.) tubes as typically used in 3" shells, or in a large tube (e.g., 2½" long x  $\frac{5}{16}$ "- $\frac{3}{8}$ " I.D. x  $\frac{5}{8}$ "- $\frac{11}{16}$ " O.D.) such as would be used on top of a 4" or larger single-break shell.

Fill cut stars in the case around a canulle of the usual (e.g., 1") diameter for a 4" shell. Special care must be given to making sure they are well-consolidated and filled also to a *uniform* depth throughout the shell case. Fill the canulle with powder, and withdraw it. Finally, level the fill as required with rough powder. Tamp carefully to make sure all is firmly consolidated. Some makers prefer to sprinkle extra rough powder in among the stars as they are being filled to assure greater solidity of fill, although this practice is less necessary if the stars are cut appropriately small so that they fill densely without much air space. The case is now ready to be closed with the spolette disc on top.

Having completed this operation in one of several methods to be described later, once the spolette with disc is inserted into the filled break case, the overhanging paper is pleated down over this disc, the folds consolidated, and another disc placed over the spolette just as for a single-break shell. At this point, the assembled break may be spiked. Adding the outside bottom disc to be held on by the spiking, the normal number of *vertical* passes only for a shell of this size (in the 4", 16 verticals of two strands of 8- or 10-ply cotton) are wound on. Instead of proceeding with the circumferential spiking, tie the string off on the spolette. Figure 44 shows the spiked bottom (last, or second) break of the shell.

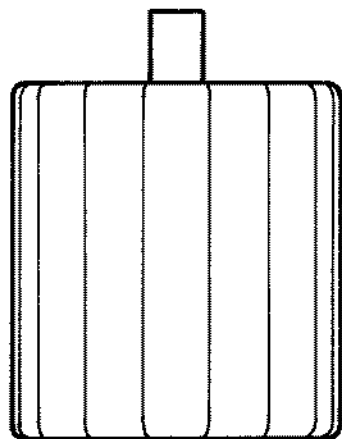

Figure 44. Final break of shell spiked with vertical string only.

The step next taken is to build the first of the two breaks. Roll a casing, again with a 6" x 48" strip of 70-lb. kraft. Close the bottom of this case with a *punched* end disc having a hole of suitable diameter to accommodate the spolette of the second break (this will depend upon how that spolette has been prepared, as discussed later). The overhanging paper is pleated down so as not to obstruct the hole, and the folds consolidated. This case is then set on top of the spiked bottom break with the spolette of that break sticking through the hole in its bottom disc. Now lower the canulle over this matched spolette and fill stars in the break case around it, consolidating as usual; fill the canulle with powder and withdraw. Level the fill with rough powder and close the break with a spolette and end disc. The spolette should be the *usual* (large tube, 2½" long x  $\frac{5}{16}$ "- $\frac{3}{8}$ " I.D. x  $\frac{5}{8}$ "- $\frac{11}{16}$ " O.D.) tube for a 4" shell, charged with  $\frac{1}{4}$ " of powder. This spolette goes with the nosed, matched end into the break as for any shell.

At this point the break will be sitting loosely on top of the already-spiked bottom break. Effort should be made to get the breaks to line up straightly. If the top of the lower break is sloping, the shell must be shimmed between the breaks with pieces of chipboard until the breaks are perfectly aligned.

Now proceed to spike the breaks together. Again, the usual number of vertical strings (16 verticals of two strands of 8- or 10-ply cotton) are spiked on, in such a manner that *these* strings fall *between* those already spiked on the bottom break. Figure 45 shows the arrangement of these strings. When all the vertical strings have been put on, the string passes the spolette and goes in spiral fashion quickly down to the bottom of the shell, just as for a single-break shell; one turn at the bottom pinions the vertical strings previously spiked on both the bottom break and the assembled two breaks. This string then proceeds up from the bottom, making little squares with respect to the spacing of the *last* verticals put on the assembled breaks (in other words, disregarding the verticals spiked on the bottom break alone); in a 4" shell, spacing of horizontal spiking would thus be about  $\frac{1}{2}$ "- $\frac{5}{8}$ ". This continues until the joining of the two breaks is reached, at which point the string begins to be laid close together, beginning  $\frac{1}{2}$ "- $\frac{1}{4}$ " below the joining, covering completely over it, and  $\frac{1}{4}$ "- $\frac{1}{2}$ " above it. From this point, spiking is continued on the top break until finally complete, concluding by throwing the usual half-hitch loop over the shell at its top, as for any shell.

The spiked shell at this point may be tested for straightness by rolling it on a table, or looking along its side, as if examining a pool cue. If it "cambers", i.e., shows a bend at the joint, it is difficult to fix it once spiked, although some success may be had by rolling it back and forth on a heavy workbench with much pressure on the joint. A crooked shell is difficult to paste in smoothly and may not fit well in the mortar if the bend is very pronounced. Generally a crooked shell is not as serious a problem in a two-break as it would be in a shell of more breaks — this is why it is wise to begin making multiple breaks with two-break shells, proceeding to shells of more breaks as experience is gained in the careful, level filling of the breaks.



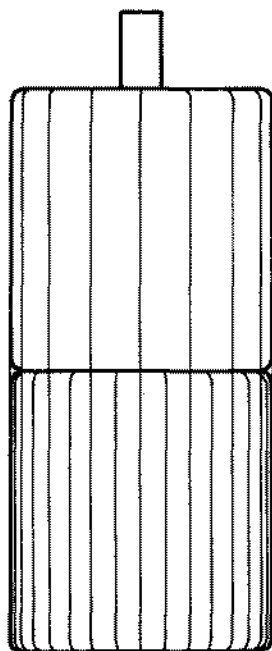

Figure 45. Spiking of vertical strings on the two assembled breaks.

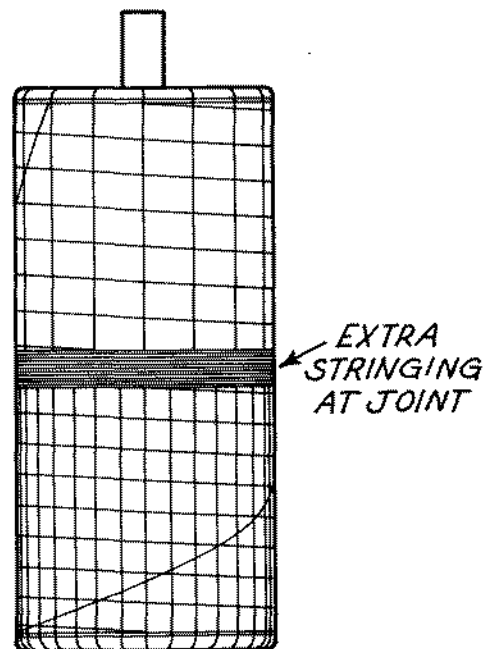

Figure 46. Completed horizontal spiking of shell.

Assuming the spiked shell to be satisfactorily straight, paste it in with three turns of 70-lb. and two turns of 40-lb. kraft. Allow the 70-lb. to dry before adding the 40-lb. kraft. The crown may be twisted down around the spolette more expeditiously than torn down in the 4" size. Care should be taken to build up a crown that will adequately support the spolette, just as when pasting in a bottom shot. Because of their extra weight and length, multiple break shells are subjected to more stress both in being blown from the mortar and in their flight upwards. No pains should be spared to assure the shell will reliably withstand this stress.

Lift with one ounce of FFA powder per one pound of shell weight, and finish with a leader of appropriate length, using the customary techniques for single-break shells as described in Part I.

#### Notes on spolette orientation

Various methods of matching and nosing the spolette to be used between two breaks of a multiple break shell are used by different makers, with each claiming advantages for his own method and pointing to faults in other methods. Figure 47 illustrates three different ways of orienting, matching, and nosing the intermediate spolette.

In method #1, the spolette of the second, or succeeding, break, is matched and nosed just as for a single break (the only difference being its shorter charge of powder). After the break is spiked as pre-

viously described, the powder surface of the spolette is scratched, and match tied over it in "rabbit-ear" fashion as described for the spolette of a bottom shot. The first break case has a bottom disc with a large hole punched in it to accommodate this spolette when set atop the spiked second break for filling and assembly. Shellbuilders who use this method point to positive and straightforward ignition of the intermediate spolette, and the vigorous blow-through of the matched and nosed end into the succeeding break; detractors of the method deplore the "sloppy" fit of the disc at the bottom of the first break case, making it difficult to line the breaks up in assembly and spiking, and allowing potential entry of fire. Needless to say, the careful sealing around the spolette of the second break with generous amounts of glue is an important step in this method.

Method #2 orients the spolette in the reverse fashion of method #1, with the end that is rammed flush with powder placed inside the second or succeeding break, with the hollow end outside ("flush-end-in"). In order to assure ignition, a groove is scraped in the powder on the flush end, using an awl. Perpendicular to this groove, two lengths of match (approximately 3" long) are bent together, down over either side of the spolette. There they are tied,  $\frac{3}{4}$ " - 1" down on the spolette, with a clove hitch of pasted or tarred twine (which will stick fast to the sides of the spolette tube and guard against the match slipping off). The ends of these pieces of match, above this

TRADITIONAL CYLINDER SHELL CONSTRUCTION

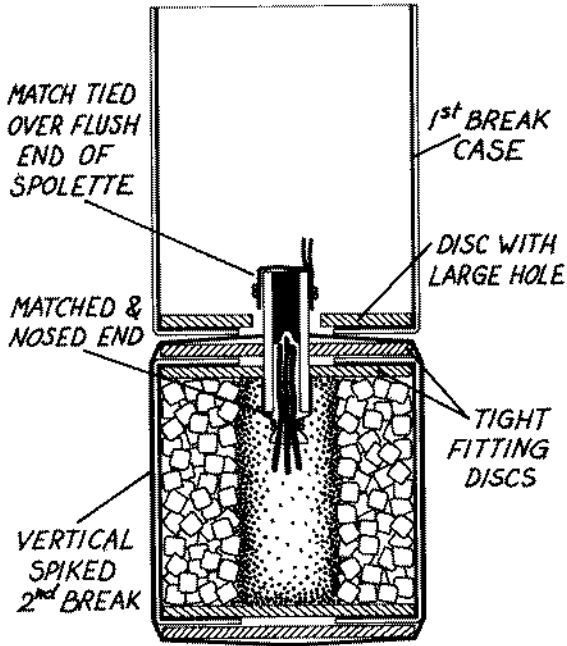

METHOD #1

A. FULCANELLI

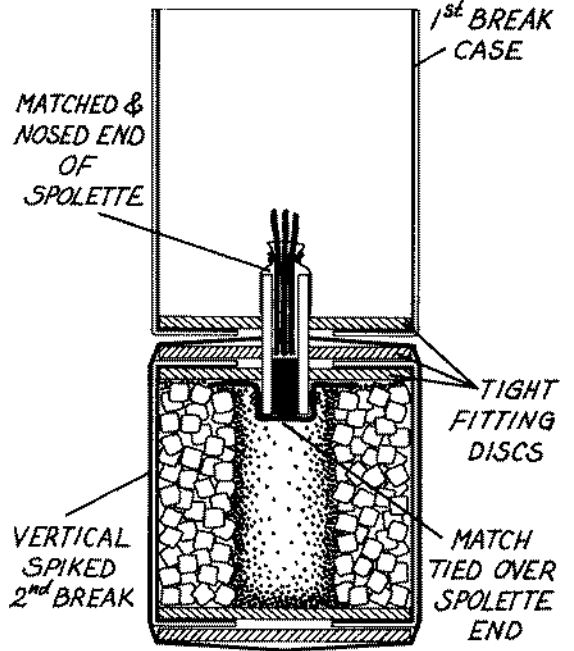

METHOD #2

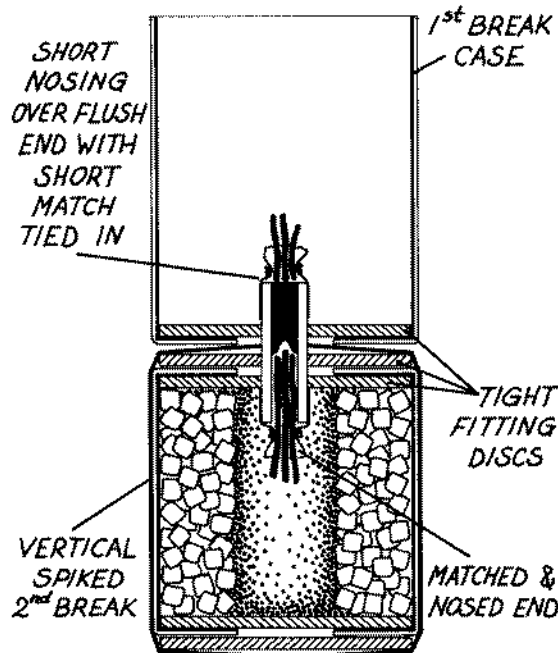

METHOD #3

Figure 47. The three methods of orienting intermediate spolettes.

tie, are bent back and the spolette pushed through a punched end disc so that this match lies flat against the disc, in the shape of an inverted top hat. The assembled, matched and fused disc is then pushed down against the contents of the filled break. The hollow end, protruding from the break, may either be matched and nosed before assembly of the break, or after the break is spiked. The inside surface of powder should in any event be roughened by scratching before match is inserted, and the nosing should be pierced beneath the tie. The first break case, in this method, has a tight-fitting punched disc the same

size as the other two end discs. Users of this method regard this as an advantage, made possible because the match is tied *into* a nosing rather than *over* the spolette's end; the breaks line up more readily and there is said to be less chance of fire getting in at the joint and spoiling the sequence of the breaks. However, this method is held by practitioners of method #1 (the "flush-end-out" method) to be prone to misfires. It is certainly dependent upon use of the best possible match, and great care at all stages of the work.

Method #3 is a compromise between the two prior methods. In this method, the flush end of the inter-

mediate spolette is outside the break, and after spiking the end is scratched, slurry-primed and dredged in grain powder. Making sure that none of this adheres to the sides of the spolette tube, it is allowed to dry, then a short nosing is pasted on and filled with short pieces of match, finally being tied off. The first break case has a tight-fitting punched end disc. This method combines advantages of methods #1 and #2, but requires much more manipulation.

**Construction of a 4" shell of two breaks of color and report**

The effect of this shell — first, a break of color; next, another break of color, and finally, a heavy report — results from a combination of the technique used to build color and report shells and that used to build the two-break color shell previously described. It is, in fact, a second color break stacked on top of a color-and-report.

Needed to build this shell will be a bottom shot of suitable size, equipped with a spolette charged with 3/4" of powder; an intermediate spolette, charged with 3/4" of powder; and an initial spolette charged with 1" of powder. Also needed are paper cut for the color and report (9-10" x 48", 70-lb. kraft) and for the first color break (6" x 48"), and seven 3 1/2" discs (two solid, and five punched for spolettes).

Begin by rolling the color and report case, either over the matched bottom shot or for use with the saw-

dust method as preferred. Assemble the color and report as previously described and close with the intermediate spolette; spike, with the usual 16 verticals of two strands of 8- or 10-ply cotton, tying off on the spolette as in the example of the bottom break of a two-break color shell, rather than proceeding with circumferential spiking.

Match the color and report assembly in the preferred manner; set the first break case (closed with the punched disc on the bottom as in the example of the two-break color shell) atop the color and report assembly. Fill this and close it with the disc equipped with the initial spolette. Ascertaining that the breaks are squarely in line, spike, again as in the example of the two-break color shell, laying the 16 verticals between those of the color and report. When these are complete, spiral down to the bottom, taking one turn to pinion the strings (as in the color and report example) and come up wide over the report. Begin spiking to form little squares over the color portion of the color and report; lay the string closely together at the joint, as for the two-break color shell; continue over the first break, making little squares, finally tying off at the top of the first break, in customary fashion.

This shell should be pasted in with at least four turns of 70-lb. kraft, and possibly five. As with any shell having this much pastewrap, no more than three turns should be put on at once; two turns may be put on as a band, covering the sides of the shell and lapping over very slightly on either end, and when this

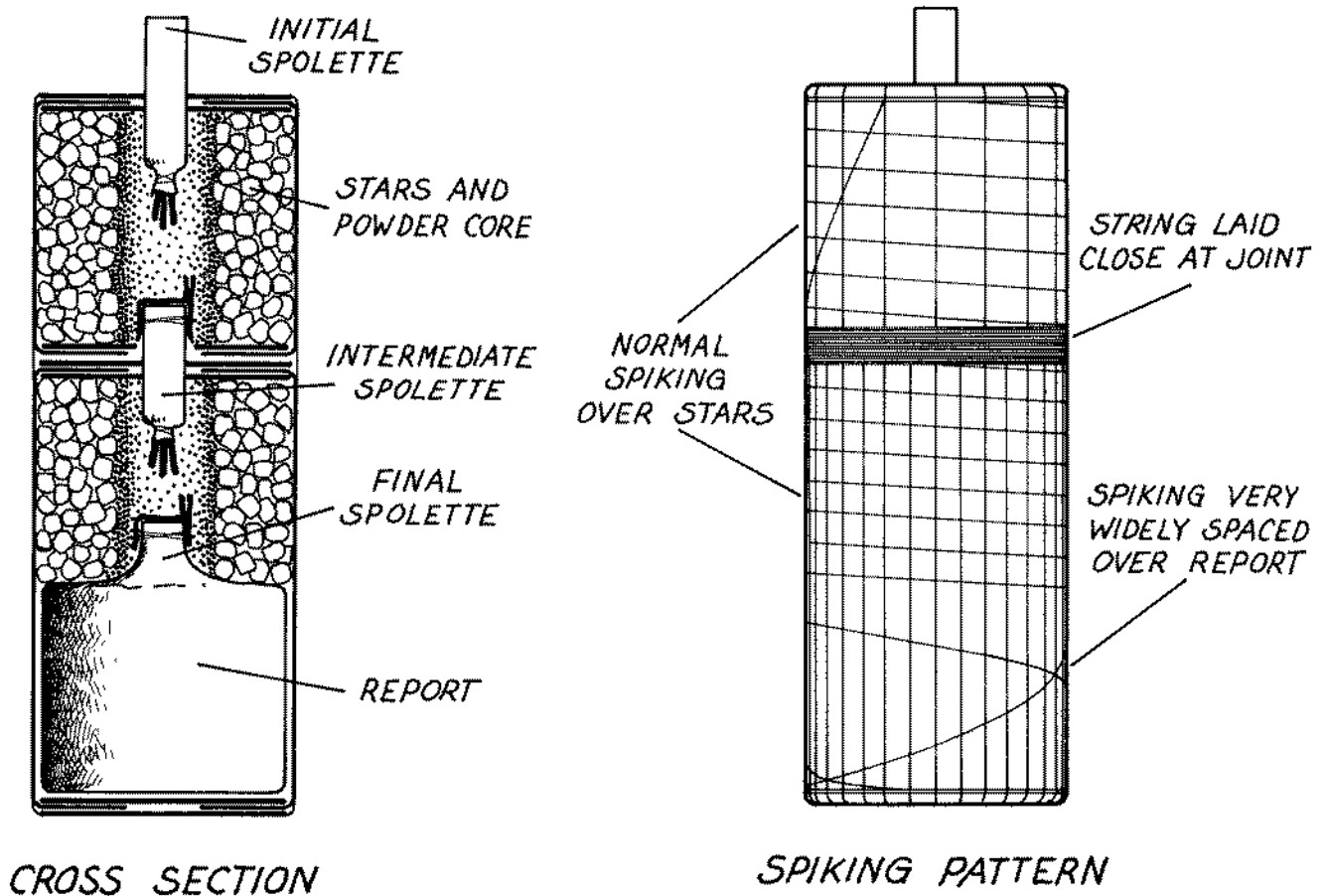

Figure 48. Two-break color and report shell.

is dry, two or three more turns put on, overlapping the ends to cover the bottom completely, and to form a crown around the top spolette. When dry, the shell should be fitted with lift charge at the rate of one ounce per pound of shell weight, and leader.

Figure 48 illustrates cut-away and external views of the shell, showing patterns of filling and spiking. Needless to say, the greatest care needs to be taken to fill the breaks solidly, to spike tautly, and to keep the breaks in line avoiding crookedness; as well as to paste soundly. The heavier and more elaborate a multiple-break shell is made, the more important meticulous attention to these requirements becomes in order to avoid malfunction.

**Construction of a 4" shell of three breaks of color**

This shell produces three effects in the air like the type previously described, but instead of the final one being a report, it is another break of color. The method of construction is the stacking and sequential spiking of three breaks, as contrasted with the previous example in which the final effect — the report — was enclosed in a long case and only two breaks (in essence) were joined and sequentially spiked.

Two intermediate spolettes (each charged with 3/4" of powder), and an initial spolette (charged with 1" of powder), three 6" x 48" strips of 70-lb. kraft, and two solid and nine punched discs are required. Roll up one of the cases and close with a solid disc; roll up the other two and close with punched discs. Fit the spolettes into their respective discs.

Fill the last (third) break first, using the case with the solid bottom disc. Close with one of the discs having an intermediate spolette fitted to it; pleat the overhanging paper down, and place another of the punched discs over the spolette and down onto the folds. It is particularly important that this bottom break be filled solidly and that it be square and level across its top. Spike, using 16 verticals only, as in the two-break color shell earlier described.

The second break case may now be positioned over the third break just finished; fill, and close, using the other disc with the intermediate spolette, pleating down the paper and placing another disc over the folds. The assembled two breaks may then be spiked together, as in the two-break color shell, laying the spiking of the second break between the spiking of the third break; and when the verticals are finished, tying off on the spolette as before.

Finally, the first break (the last to be added) is to be stacked on the two breaks previously spiked together; it is filled, closed (using the initial spolette and its discs), and the spiking completed. Again, the vertical strings are laid between those on the two breaks previously spiked. While it is easy to lay them between the ones on the second break, it requires somewhat more effort to achieve this on the third break as well, since that break is doubly spiked. If the strings are not so spaced, however, they begin to enlarge the bottom of the shell in a fashion that

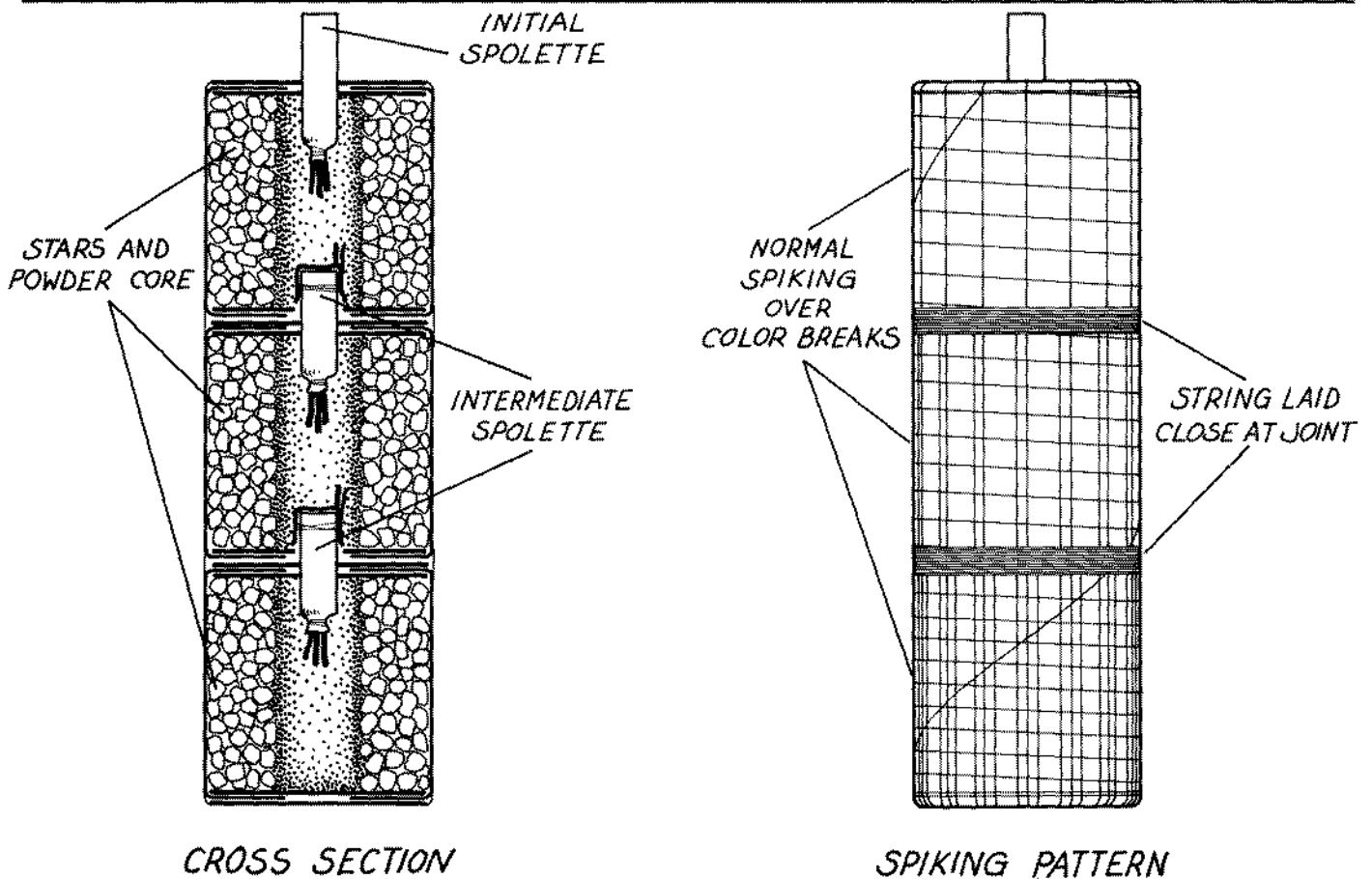

Figure 49. Three-break color shell.

makes rolling up the pastewrap squarely very difficult (because the shell is no longer a true cylinder). When all verticals are in place, spiral down the side to the bottom; take one turn to pinion the strings, then commence spiking upwards, making little squares. At the two joints between breaks, the string is laid closely together, as in previous examples. Finally, the string is tied off at the top as usual. Figure 49 illustrates cross-sectional and spiked views of this shell.

The pastewrap of this shell is, as with the two-break and report shell, with at least four and possibly five turns of 70-lb. kraft. The usual procedures for pastewrapping, lift, and leader are employed.

It will be noted that as more breaks are added, the tendency for the shell to become crooked is increased. The best way to prevent this is to build the breaks as squarely as possible. Some manufacturers find the use of a chipboard liner, back-spun into each break case, helps in establishing a uniform "fill level" so that each break will be square and of consistent size.

As discussed in the example of the two-break color shell, it is possible to straighten a shell that is slightly crooked by rolling it on a sturdy table and applying pressure on the joints, as it were, bending them back into shape. This is more easily done while only vertical strings are on the shell, as when the second and third breaks are spiked together. Some makers prefer, thus, when spiking the final time (after the addition of the first break) to tie off on the spolette, and take this final opportunity to test for straightness and correct, if need be, before spiking the circumferential turns separately. Circumferential spiking tends to lock in the vertical spiking previously done, and to tighten and harden the shell, such that if crookedness is present, it will become almost impossible to work it out by rolling.

**Shells of more than three breaks**

The previous examples illustrate all the techniques for building still more elaborate multiple break shells, by combining the color-and-report technique with the stacking of many additional breaks. Thus, by simple

extension of previous examples, it may be seen that four-, five-, and even more breaks may be built, with or without a final bottom shot. As the number of breaks increases, a few special considerations must be taken.

Most important of these is the regulation of spolette timing. While, as will be evident from the preceding descriptions, spolettes used for timing between breaks (intermediate spolettes) and for the first break (initial spolettes) are made in the same way as for single-break shells, there is variation in the length of the powder increment charged. The time that elapses between breaks need be only as long as the effects in the preceding break take to burn out before that break opens. Also, as breaks are added, the time between each must be shortened so that all breaks open at suitable altitudes for visibility and safety. Finally, as more breaks are added, the time on the initial spolette must be shortened so as to begin opening the shell on the way up. Table 18 below indicates these particulars for multiple-break shells.

In practice, 3/4" is the shortest permissible charge for an initial break spolette, and 1/2" for an intermediate spolette. Given usual practices relating to lift charge and mortar length, these rules work well for shells even of seven or eight breaks, and any maker attempting shells of more breaks should do so only after long experience. In normal commercial practice, it is rare to see shells of more than five breaks. A total of 3" of powder in all successive spolettes ordinarily should not be exceeded.

Another consideration in building long shells is that the use of a report on the bottom greatly strengthens the shell, making it more capable of receiving a heavy blow from the lift charge. Also, and because of similar concerns, the lift powder used is often screened through 8x8 hardware cloth (1/8" openings), and that retained on the screen used for long or heavy shells. The coarser powder burns more slowly and is a gentler lift; it is more a sustained and strong push, than a sharp kick.

**Added garnitures in breaks of multiple break shells**

The combination of various special garnitures with cut stars is effectively used in shells of multiple breaks.

**Table 18. Specifications for spolette tube dimensions and powder charges for multiple-break shells.**

Shell size	Intermediate tube dimensions			Initial spolette charge*	Intermediate spolette charge
	i.d.	o.d.	length		
3"	5/16"	.55"	1 1/2"	2, 3 break: 1" 4, 5 break: 3/4"	2, 3 break: 3/4" 4, 5 break: 1/2"
4"	5/16"	.55"	2"	2, 3 break: 1" 4, 5 break: 3/4"	2, 3 break: 3/4"
	5/16"-3/8"	11/16"	2 1/2"		4 break: 3/4" or 1/2" 5 break or more: 1/2"
5"	5/16"-3/8"	11/16"	2 1/2"	2 break: 1 1/4"	2, 3 break: 3/4"
				3 break: 1" 4, 5 break: 3/4"	4 break: 3/4" or 1/2" 5 break or more: 1/2"
6"	5/16"-3/8"	11/16"	2 1/2"	2 break: 1 1/4"	2, 3 break: 3/4"
				3 break: 1" 4, 5 break: 3/4"	4 break: 3/4" or 1/2" 5 break or more: 1/2"
8"	5/16"-3/8"	11/16"	3"-3 1/2"	2 break: 1 1/2"	2, 3 break: 3/4"
				3 break: 1"	

\*NOTE: Dimensions for the initial spolette tube are same as given in Table 5, p. 12, Part I, in PYROTECHNICA • IX.

In this situation, spolette timing can be lengthened for special effect, and indeed must be when delayed-effect garnitures such as saettines or others to be described later are employed. This assures that they may have their effect prior to the opening of the following break.

A typical example might be a 4" shell of two breaks of color and saettines, followed by a heavy report. To make such a shell, the following materials will be needed: a bottom shot, having a spolette charged with 1" of powder; an intermediate spolette charged with 1" of powder; an initial spolette charged with 3/4" of powder; twelve 1" saettines (see Part I, PYROTECHNICA • IX, pp. 32-33); paper and discs both solid and punched for spolettes.

The paper for the bottom break of color, saettines, and report should be cut 2" wider than for a simple color and report in order to accommodate the report, the saettines, and a full depth of color stars above the saettines. Depending upon the height of the report and the technique chosen for assembling it with the report case, this would lead to a strip perhaps 11-12" wide x 48" long of 70-lb. kraft. Having rolled and assembled the color and report, place six of the saettines on top of the report in a ring, the matched ends up and facing into the center. The spaces between the saettines and the case wall are to be firmly rammed with rough powder or sawdust, as preferred; the central area into which the matched spolette of the bottom shot sticks up amongst the saettines should be filled with rough powder, and a bed of rough powder leveled over the

matched saettine ends. Lower the canulle into its central position and fill to the proper depth around it with stars; then fill the powder into the canulle and remove, finally leveling with rough powder in the usual fashion. Close, using one of the discs equipped with the intermediate spolette with 1" of powder.

Spike the assembled break of color, saettines, and report with the usual 16 vertical strands of doubled 8- or 10-ply cotton. Now, prepare the case for the first break of color and saettines, using a strip of 70-lb. kraft 2" wider than usual for a normal color break, to accommodate the saettines (e.g., 8" x 48"). Close the bottom with a punched disc and pleat the ends down. The saettines may be placed in the case and the spaces filled as before, prior to setting it atop the assembled break and report. Once it is set in position, the central area into which the intermediate break spolette protrudes amongst the saettines should be filled with rough powder, the saettines covered with a bed of rough powder, and the stars and powder core filled as before above the saettines. Close with the initial 3/4" charged spolette.

Spike vertically, positioning the strings between those previously spiked on the break and report. When vertical spiking is completed, the usual spiral is made down to the bottom to pinion the strings, then spiking continues wide over the report, and over the saettines at double width, i.e., so that the horizontal strings are spaced twice as widely as the vertical ones spiked on the break, or about 1" apart. When the area contain-

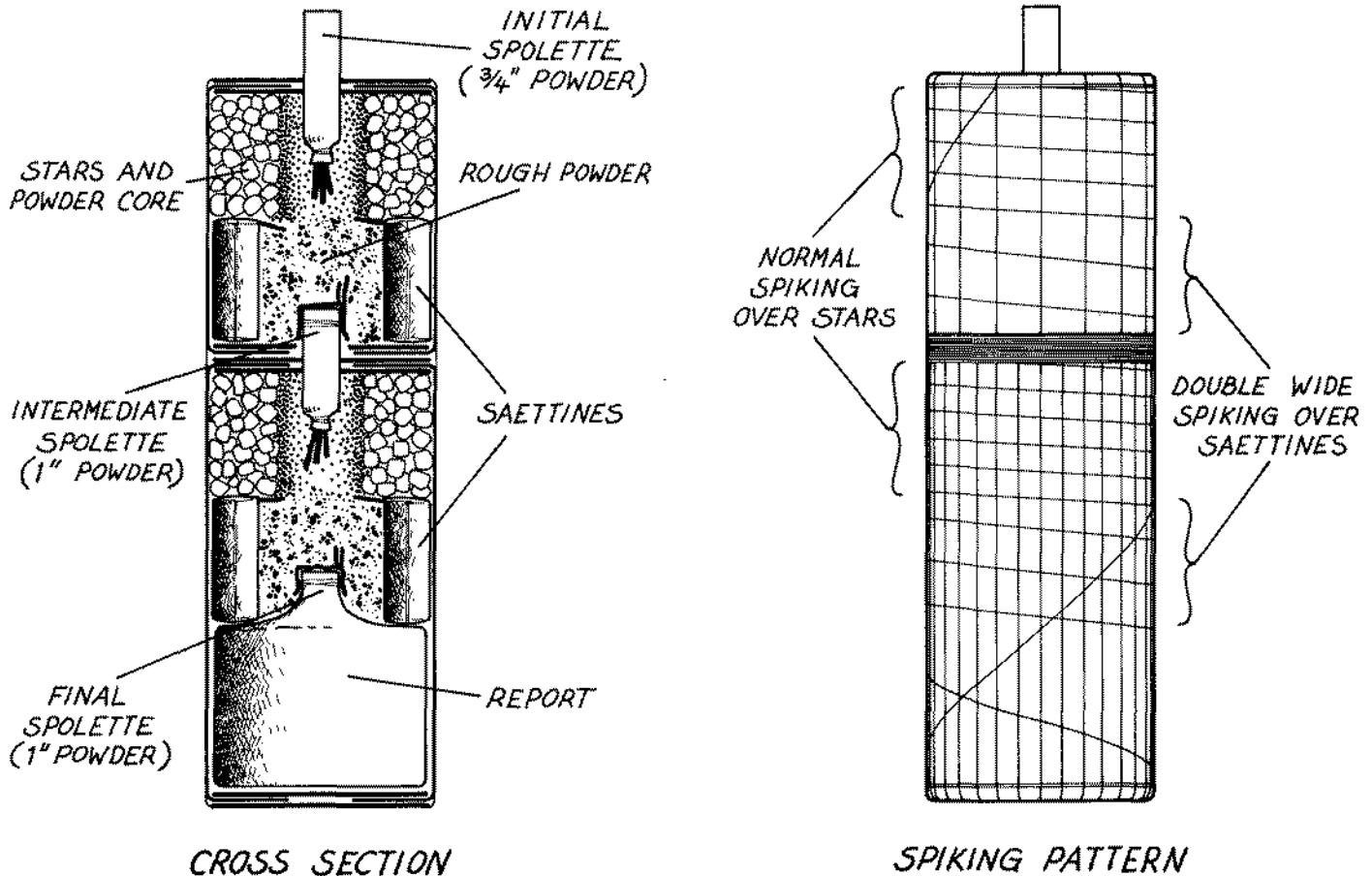

Figure 50. Two breaks of color and saettines with heavy report.



ing stars is reached, spike to make little squares; lay the strings close at the joint; spike at double width over the saettines of the first break, then to make little squares over the area containing its stars, tying off as usual. Figure 50 illustrates cross-sectional and spiked views of this shell.

Pastewrap for this shell should be five turns of 70-lb. kraft, two turns being put on as a band just lapping over the ends, and allowed to dry; then a sheet (three turns) with full overlap on either end to make a solid crown and bottom. Lift and leader are done according to the usual procedures, allowing one ounce of lift per pound of shell weight.

This example illustrates not only the lengthening of intermediate timing, but the shortening of the initial timing so as to open the shell while it is still ascending, then to allow ample time for the saettines from the first break to explode before the second break opens, and for the saettines from the second break to explode prior to the heavy report. As saettines are somewhat variable in their timing, the intermediate spolettes may need to be lengthened or shortened after an initial trial shell is made, according to the performance of the particular lot of saettines.

As a general rule, it is unwise to use more than a  $\frac{3}{4}$ " initial spolette charge on any shell with an intermediate spolette timing having more than  $1\frac{1}{4}$ " of powder.

**General remarks on multiple break shells**

While the examples given here have been all in the 4" size, in principle the methods of making these shells are the same in all sizes. The careful filling of the breaks, the assembly of the breaks with sequential vertical spiking, the final horizontal or circumferential spiking (with string laid close at the joints), and the use of ample pastewrap (perhaps one or two turns more than the number of nominal inches of shell diameter, when using 70-lb. kraft) are common features of all multiple break shells. It is usual to spike each break, when doing the sequential spiking, with the customary number of vertical passes of string for a single break of the given size (e.g., 12 passes for a 3", 16 for a 4", 24 for a 5", etc.). Effort is to be made to lay the strings on subsequent spiking between those previously spiked on the break or breaks being assembled to the break being spiked.

As the number of breaks is increased, or the diameter of the shell is increased, the stress it must undergo in firing increases, and soundness of construction becomes all the more important. Careful attention to every detail is the key to success.

**FLASH BAGS, SPIDERWEB AND "SFERA" BREAKS**

One method among many alternatives to black powder as a burst charge seems to have been widely adopted by manufacturers — the so-called "flash bag" burst. This replaces the traditional core of black powder with a charge of flash powder. The flash powder is contained in a small paper tube or bag tied to the shell fuse. This serves the following purposes:

- (1) The bag insures the ignition of the flash powder by keeping it close to the fuse.
- (2) The bag keeps the flash powder in the center of the shell; its volume is so small that it would tend to get "lost" in the shell otherwise.
- (3) The bag protects the flash powder, in handling both during and after shell assembly, from contact with stars or powder; it is feared that subject to "hammer and anvil" action between stars, it might accidentally ignite.
- (4) The presence of loose flash in the shell might cause explosion of the shell in the mortar, should a gas leak into the shell occur (instead of a flowerpot, as with a black powder burst). With a flash bag, should the shell be unsound, it will flowerpot as usual, and the bag, still tied to the fuse, will fly out of the mortar and explode harmlessly in mid-air.

Many sizes of paper tubes have been suggested for the bags, but they are most usually just two or three turns of 30- or 40-lb. kraft on a former  $\frac{3}{4}$ "-1" in diameter. The tube itself is made about  $2\frac{1}{2}$ "-3" long. Some shell makers prefer to fold one end flat and glue it, using a tongue fold or "triangle fold." The flash is then charged into the tube, the matched end of the spolette or the cross-matched end of the time fuse inserted, and the tube gathered sack-style around the fuse and tied firmly onto it with a clove hitch or two of strong twine. The other method is to tie the tube onto the fuse, leaving the other end open; in this

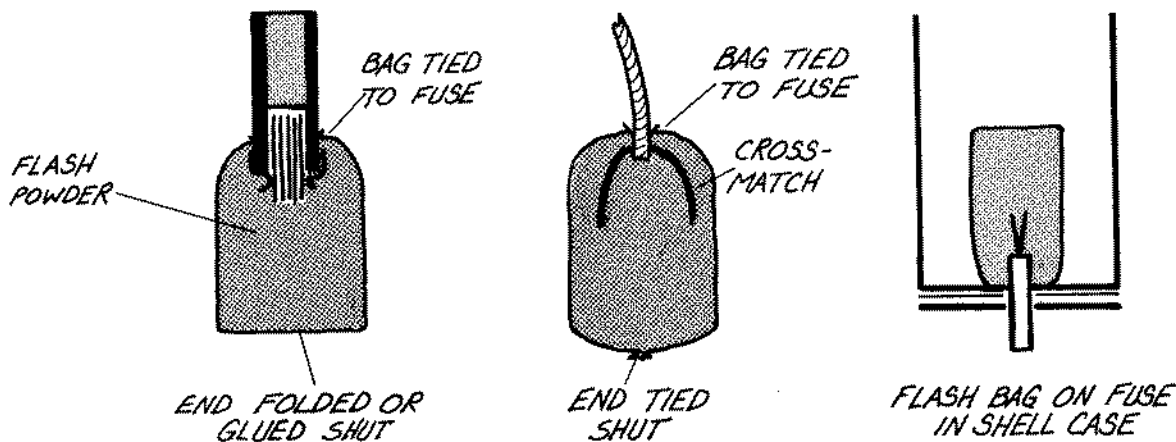

Figure 51.1 With spolette. Figure 51.2 With spun fuse. Figure 51.3 Flash bag in shell case.  
Figure 51. Flash bag assembly.



end the flash powder is charged, and the end then tied off. In either event, the fuse (with its attached flash bag) is glued into the top end disc of the shell, as shown in Figure 51.

Flash bag shells are built in an "upside-down" fashion; the former has a large recess to accommodate the flash bag on the inside of the top end disc. A piece of pipe, built up to the proper diameter with chipboard and pasted paper, may serve as a former. The case is rolled of the usual number of turns of 60- or 70-lb. kraft, slipped up a little less than half a diameter over the former end; the disc with fuse and flash bag inserted, the ends pleated down over the disc, and the outside top end disc pushed down over the fuse, onto the folds of paper. The case may then be removed from the former.

Supported in an upside-down position with the shell fuse in a hole provided on the work surface, the shell casing is then filled with stars, put in at random around the flash bag. The case (as with a conventional shell) should be patted or its contents tamped to settle them into the most compact configuration. A little rough powder may be sprinkled in to fill the interstices. After the full load of stars has been put in the casing, it is leveled off with as much of the coarser rough powder as required, and the bottom inside end disc is inserted, tamping it to further consolidate the garniture. The overhanging paper is then folded down, resulting in a shell to all appearances like any other shell. The filled shell casing, at this point, is ready to be spiked, pasted in, and finished according to the usual rules for a shell of the given size.

Modifications of the traditional techniques outlined in this article are often found in connection with flash bags. Flash bag shells are often found in conjunction with stringless shells, and in this event the inner casing is built with a chipboard liner, and the outside top and bottom end discs are cemented in place with liberal amounts of white glue, the shell then being pasted in. Many flash bag shells encountered in the trade are of a "hard case" or "can" construction, using a spiral-wound tube with flanged paper end caps. These often rattle when shaken, since they derive integrity from the rigidity of the case rather than from the solidness with which it is filled (as does a hand-rolled shell case). These "hard case" shells are sometimes stringless, and sometimes spiked with a reduced amount of string as compared to the traditional method. The objective of this is not to reinforce the shell walls to ensure a harder burst (since the flash powder alone accomplishes this) but to hold the top and bottom end caps in place. Such techniques are outside the realm of traditional construction and tend to vary widely from maker to maker; they are mentioned merely as a matter of record.

The use of flash bags appears to have originated as a method of procuring an especially hard and symmetrical burst with special, easily-ignitable stars (traditionally a golden charcoal streamer effect). A suitable formula for such a star is given in PYROTECHNICA • I, page 8, or the following may be used:

Salt peter .....	14
Charcoal (air float) .....	7
Sulfur .....	2¾
Dextrin .....	1½

These stars may be made either as cut stars or as comets. If cut stars are to be used, they may be made a little larger than typical color stars for a shell of given size; e.g., ½" cubes for a 4" shell. When pumped as comets, they are arranged around the shell wall as for any comet shell, and the space between the comets and the flash bag filled with rough powder. A shell made with cut stars of this type is properly called a "spiderweb" shell, and one made with comets in the fashion described is called a "sfera" shell. Such shells may be used as single-break effects, but it is also traditional to use a break of spiderweb or sfera as the final break of a multiple break shell. After its initial assembly, it is treated, when used in this way, just as any break would be from the point of view of spiking and assembly with other breaks. Because of difficulties with the method of construction, and also because successive spolettes will not reliably take fire from a flash bag, spider or sfera breaks cannot be used in other than the last break.

More recently, as the cost of black powder has increased, manufacturers under competitive pressure to produce a cheap product have begun to use flash bags as a standard burst for all shells, regardless of the stars used. A fraction of an ounce of inexpensive flash powder can replace several ounces of expensive commercial FFA blasting powder. Flash bags, assembled with fuses and "hard case" shell cans, as described earlier, also simplify manufacture as the shell-filling process can be performed then by less-skilled workers.

Associated with this broader use of flash bags, many problems have been encountered with the adjustment of burst strength. Common difficulties are sparse-appearing bursts and unignited ("blind") stars. Color stars do not typically ignite as easily as the traditional charcoal spider star, nor do they stay ignited at high velocities as easily. Much has been said about appropriate flash bag techniques, often having to do with unusual flash powder compositions, but a common problem is simply the use of too much flash powder. Table 19 shows suggested starting amounts.

Table 19. Charges for flash bags.

Shell size	Amount of flash
3"	⅛ oz.
4"	¼ oz.
5"	⅜ oz.
6"	½ oz.

Ordinary flash powder (Part I, Table 16, p. 34, PYROTECHNICA • IX) should be sufficient to give good results with the typical charcoal compositions either as cut spider stars or as sfera comets.

Some have contended that bright aluminum should be used in flash powder, or that meal powder should be added; the basis of these contentions being that the flash powder is thus made less brisant, or more drossy and thus better for lighting the garniture. Another school of thought calls for reducing the oxidizer content of the flash powder, and adding more than the usual amount of sulfur or antimony sulfide. Still another school claims that the route to success lies in using barium or potassium nitrates in addition to, or in place of, potassium perchlorate as oxidizers. Per-

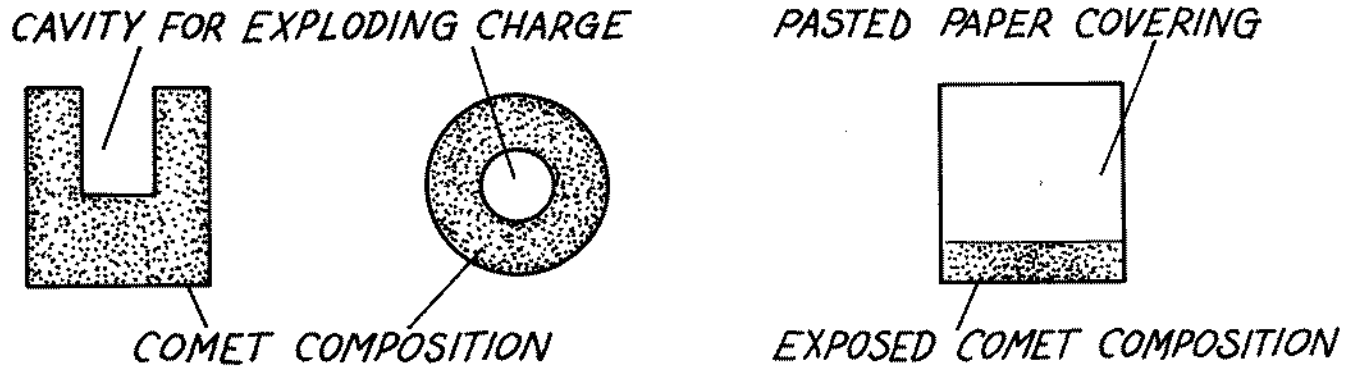

Figure 52. Crossette comets.

haps some of these suggestions have merit, but the principal problem should still be soluble by simple adjustment of the quantity of flash powder.

**CROSSETTES (SPLIT COMETS)**

Crossettes, or split comets, are a variant of the ordinary pumped comet having the effect of breaking from the shell like ordinary comets, but at some point in their trajectory (preferably after the break is well developed, but before its symmetry begins to be destroyed by the "willowing" of the comets under the influence of gravity) cracking into several fragments like a small shell burst. If the comets are well made, they will all do this at once, none cracking early (spoil the surprise) nor straggling.

Although several methods have been advanced to achieve the cracking of the comet, all of them rely on the formation of a cavity in the center of one end of the comet. In this cavity is placed a small exploding charge. The comet is then covered on the sides and the cavity end so as to restrict burning to the solid end and a small area of the sides. These portions of the comet ignite as the shell opens, and when the comet burns down to the explosive charge, that charge takes fire, cracking the comet in several pieces. Figure 52 illustrates the crossette comet in cross-section, from the end, and the exterior, from the side.

The successful achievement of the crossette effect is one involving much tedious work. Patience and practice will, however, bring great rewards.

It is first necessary to pump crossette comets. A special pump must be made to form the cavity, or

"shot hole" in one end of the comet. For purposes of this discussion, the comets described here will be made 1 1/4" in diameter and 1 3/8" in length — a good size for 5" and 6" shells which are typical sizes for crossettes. The "shot hole" should be 3/4" deep by 1/2" in diameter. The pump should be made as an ordinary pump so that the pin, when held against the top of the sleeve, makes the face of the plunger stand 1 3/8" from the bottom of the sleeve. The slot in the side of the pump should allow the plunger to be pushed down so that the face of the plunger is flush with the bottom of the sleeve. Figure 53 illustrates the crossette pump together with the comet, showing the dimensions. It may be understood that the peg, or protrusion machined in the face of the plunger to form the shot hole can taper a few thousandths of an inch from its base to its tip, and also a slight radius should be machined at its base and on its edges, to help the pumped comet "deliver" smoothly, without cracking, after it is rammed.

It is traditional that crossettes be pumped of a charcoal streamer composition, although they can also be made with white or gold flitter mixtures with good effect. It is important to the physical integrity of the comets that they be pumped with heavy pressure, ramming with several blows of a heavy mallet. The comets must be cut to a uniform length (as described in Part I, pp. 28-29, PYROTECHNICA • IX); this is important not only because it is desirable that they stack properly in the shell, but *principally* because the distance between the solid bottom of the comet and the bottom of the "shot hole" determines the delay between the ignition of the comet and its bursting.

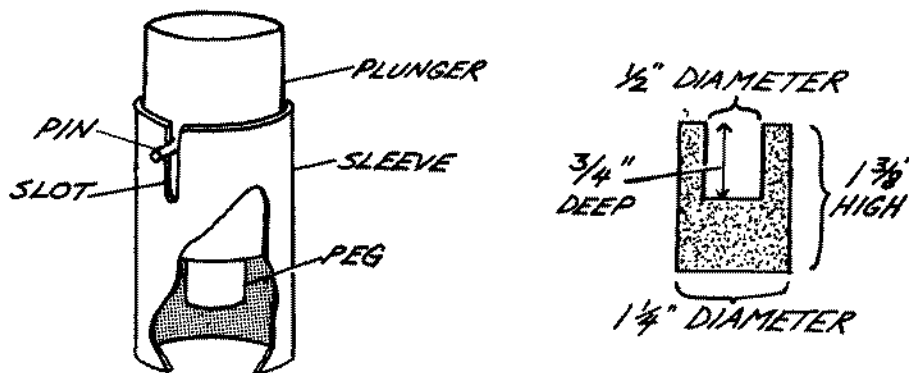

Figure 53. Crossette pump and comet showing dimensions.



Removing crossette comet from star pump.

The comets should be allowed to dry for several weeks after pumping, as they are large and charcoal compositions dry slowly. It is important that they are dried thoroughly before they are finished and put in shells, and attempts to "force" drying may result in cracks that render the effect of the finished comets less uniform because of premature explosions.

The small explosive charge to crack the comet is contained in a small hand-rolled case known as a "hole shot." In order to prepare the hole shots, cut 125-lb. tagboard (.009" thick) into pieces  $\frac{5}{8}$ " wide x  $2\frac{3}{4}$ " long, with the grain  $\frac{5}{8}$ " wide; this serves as a liner. Also cut 30-lb. kraft into pieces  $1\frac{3}{8}$ " wide x  $4\text{-}9/16$ " long; this serves as an outer wrap. The small piece of tagboard is laid centered on one end of the piece of kraft and both are rolled up together on a  $\frac{3}{8}$ " rod. Slip the tube thus formed up over the end of the rod so that the kraft overhangs and the tagboard is flush with the end; close with the triangle fold and consolidate the folds by rapping the end of the rod, with case over it, on the table. The procedure is exactly like that for saettines (Fig. 33, p. 31, and text pp. 31-32, Part I, PYROTECHNICA • IX), except that it is unnecessary to paste the edge of these small casings.

The shot case may be filled with flash powder, but it is traditional to use a "dark report" composition which does not give a brilliant flash upon explosion. The reasons for this are two-fold: (1) the delicate orange-gold of the charcoal composition would

be obscured by a bright flash, and (2) the "dark report" compositions, though made of rather hazardous ingredients, are actually milder than a flash powder containing aluminum, which would tend to shatter the comet into dust rather than cracking it into three or four pieces as desired.

Table 20. Dark report compositions for crossette shots.

	A	B	C
Potassium chlorate	1	4	3
Antimony sulfide	1	1	2
Sulfur	—	1	1

These compositions should be made in ounce proportions and carefully mixed, away from other fireworks materials. Although shock- and friction-sensitive, since handled in small quantities and quickly charged into shots containing only a few grains, the compositions may be used with relative confidence.\*

A convenient scoop may be made with a steel pen nib inserted backwards into the pen holder. The composition should be filled about  $\frac{1}{2}$ " deep in the shot, or about  $\frac{3}{4}$  full. The open ends of the shots should be folded shut with the triangle fold so that the points of the triangles oppose on either end, as with saettines. Figure 54 illustrates various views of shots.

As the shots are filled and folded shut, they should be laid neatly in rows on a tray with the folded tops all oriented in the same direction, the previously folded bottoms the other direction. This helps in the tying procedure to follow as it is easier to lay the string under the more loosely consolidated top fold.

The folded ends of the shots are held shut with pasted string. One strand of 8-ply cotton, or better yet one strand of 3-ply Belgian flax is used. Load a spiking horse with the string and smear it well with paste. Unloop a length of string and, holding the string taut with one hand, pick up a shot with the other and lay the string underneath the top triangle fold, nestled firmly at the base of the fold. Grasping the shot by its top and bottom, using the thumb and forefinger of one hand, form a half-hitch loop of the string with the

\*ED. NOTE: In some countries manufacturers cannot legally employ chlorate-sulfur mixtures. In such cases, a granulated mixture of potassium perchlorate or chlorate and dark German pyro aluminum can be substituted in the shots. This flash mixture has the drawbacks mentioned above, but with careful adjustments can be used successfully.

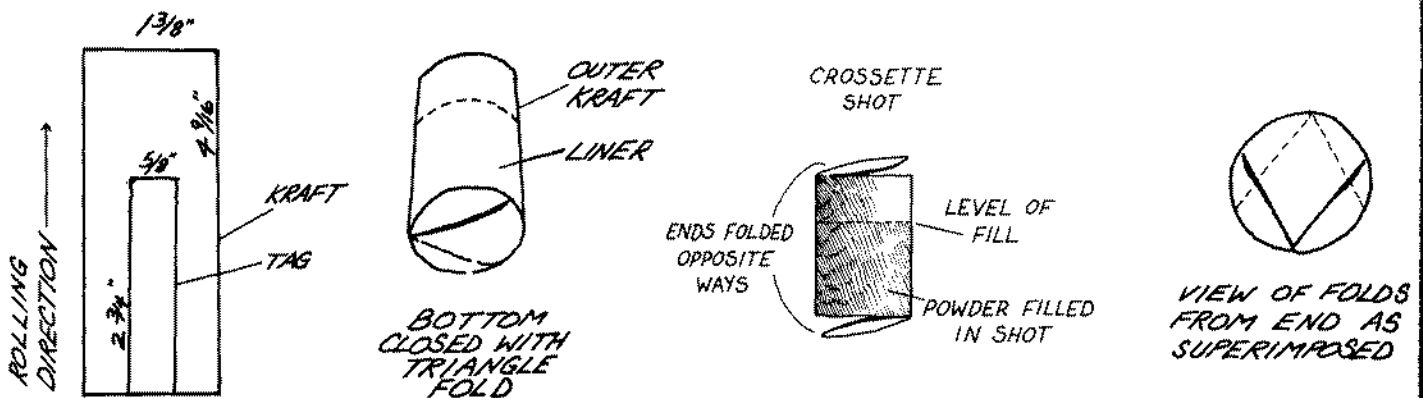
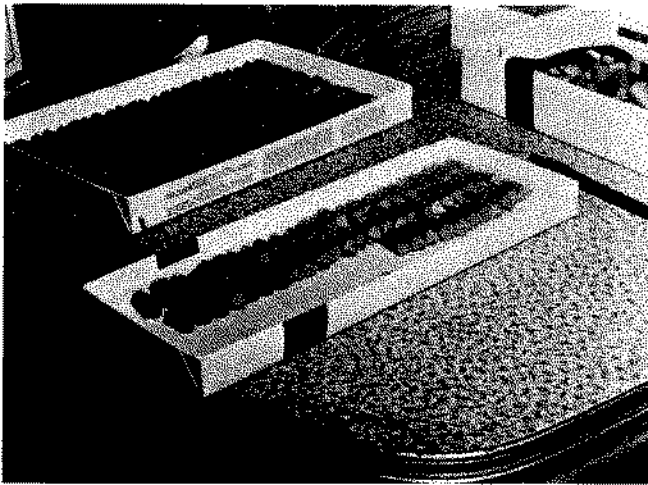

Figure 54. Rolling and filling crossette shots.



Crossette shots ready for tying.

other hand and cast it over the shot, lengthwise, over the top triangle fold. This requires a slight shifting of the thumb and forefinger holding the shot. Grasping lightly with this thumb and forefinger, sufficiently to hold the string in place, pull the loose end of the string taut so the shot is firmly tied but without crushing. The procedure may be repeated with another shot, placing this in front of the shot just tied, so that shots are spaced along the string every two to three inches until the string is five to six feet long. These strings of shots are then tied to hooks in the ceiling, and a small weight tied to the bottom of the string, which is allowed to dry under tension. Figure 55 illustrates the strung shot, and procedures for tying.

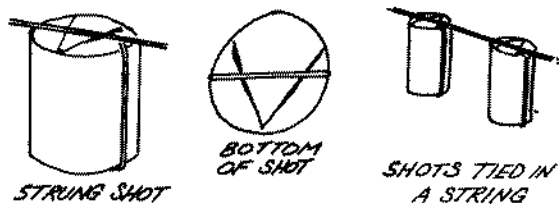

Figure 55. Tied crossette shots.

After the shots are tied and the string has dried, they must be cut apart. The dried, stiffened, pasted string should be left for about ¼" on either side of the top of the shot, forming little "ears" the purpose of which will soon become apparent.

Thin match should be prepared to fuse the shots. This may be made from several strands of very thin, absorbent cotton thread (such as darning cotton) or from one strand of 8-ply cotton string. The slurry should be made from all commercial meal powder with one ounce dextrin to the pound of meal. Soak the cotton well in the slurry and draw it through a small aperture, perhaps an eye dropper tube, to form it, as it is wound onto a small frame. Finally the still-damp match is dusted with commercial meal powder.

Procure an awl of sufficient diameter and taper that it will form a hole when piercing with about the first half-inch of its length sufficiently large to accommodate a piece of the thin match. Make a "stop" on the awl with a band of pasted paper or tie a few clove hitches of pasted string on it, so that it can pierce only to that depth.

Now the shots must be pierced on their bottoms to receive a piece of thin match. The hole should be made toward the edge so that the rigidity of the liner helps to support the end of the shot, and the shot is not collapsed by the awl. It is essential that the awl be very sharp, and the hole be pierced in a straight in-out motion, without twisting or anything that could lead to unnecessary friction that might ignite the report composition. When performing this operation, the shots should not be held by the fingers but should be placed in a holder. This is a piece of wood with a hole drilled at the edge the size of a shot.

The match should be cut in pieces about 7/8" long, using a razor blade and cutting at an oblique angle (which will help it go into the pierced holes easily). Finally, insert the match into the hole in the shot, bend square over the bottom, and insert the shot into the comet. If all has been well done, the shot should be a "press fit" in the shot hole, matched end down, filling it just to the proper height so that the string lays flat against the top of the comet. Figure 56 illustrates various phases of manipulation of the shot and comet.

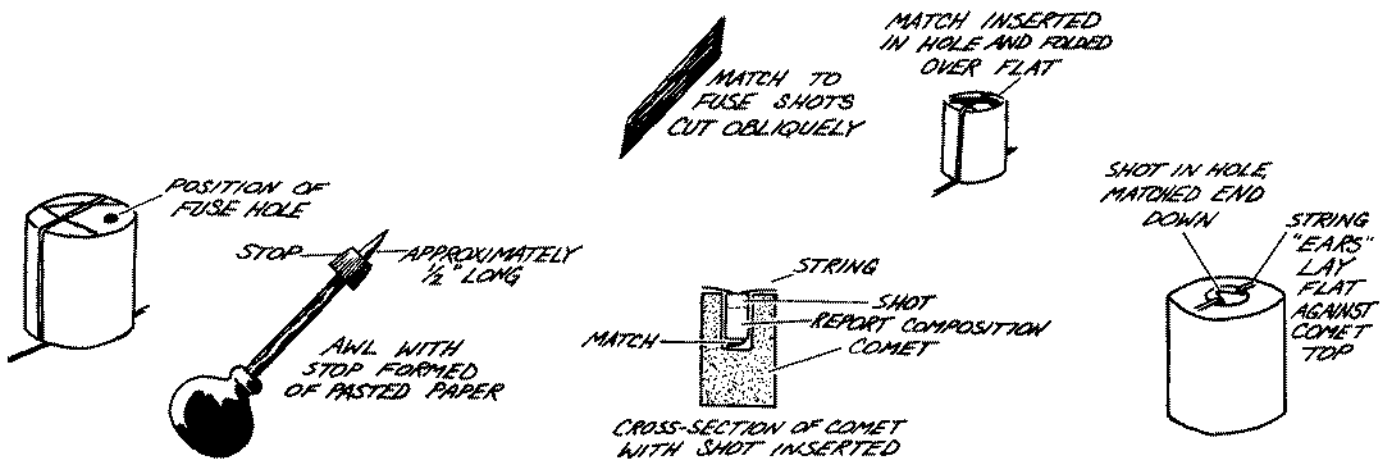

Figure 56. Crossette shots fused and inserted in comets